

SCPI Command Reference - Volume 1

Agilent Technologies E4428C/38C ESG Signal Generators

This guide applies to the following signal generator models:

E4428C ESG Analog Signal Generator

E4438C ESG Vector Signal Generator

Due to our continuing efforts to improve our products through firmware and hardware revisions, signal generator design and operation may vary from descriptions in this guide. We recommend that you use the latest revision of this guide to ensure you have up-to-date product information. Compare the print date of this guide (see bottom of page) with the latest revision, which can be downloaded from the following website:

<http://www.agilent.com/find/esg>

Notice: This document contains references to Agilent. Please note that Agilent's Test and Measurement business has become Keysight Technologies. For more information, go to www.keysight.com.



Agilent Technologies

Manufacturing Part Number: E4400-90506

Printed in USA

April 2015

© Copyright 2001–2015 Keysight Technologies, Inc.

Notice

The material contained in this document is provided “as is”, and is subject to being changed, without notice, in future editions.

Further, to the maximum extent permitted by applicable law, Agilent disclaims all warranties, either express or implied with regard to this manual and to any of the Agilent products to which it pertains, including but not limited to the implied warranties of merchantability and fitness for a particular purpose. Agilent shall not be liable for errors or for incidental or consequential damages in connection with the furnishing, use, or performance of this document or any of the Agilent products to which it pertains. Should Agilent have a written contract with the User and should any of the contract terms conflict with these terms, the contract terms shall control.

SCPI Command Reference, Volume 1

1. SCPI Basics	1
Command Reference Information	2
SCPI Command Listings	2
Key and Data Field Cross Reference	2
Supported Field	2
SCPI Basics	3
Common Terms	3
Command Syntax	4
Command Types	5
Command Tree	6
Command Parameters and Responses	7
Program Messages	12
File Name Variables	13
File Types and Directory Structure	14
MSUS (Mass Storage Unit Specifier) Variable	16
Quote Usage with SCPI Commands	17
Binary, Decimal, Hexadecimal, and Octal Formats	18
2. Basic Function Commands	19
Correction Subsystem ([:SOURce]:CORRection)	20
:FLATness:LOAD	20
:FLATness:PAIR	20
:FLATness:POINts	20
:FLATness:PRESet	21
:FLATness:STORe	21
[:STATe]	21
Digital Modulation Subsystem—E4438C ([:SOURce])	22
:BURSt:SOURce	22
:BURSt:STATe	22
:DM:EXTernal:ALC:BANDwidth BWIDTH	22
:DM:EXTernal:HCRest[:STATe]	23
:DM:EXTernal:FILTer	23
:DM:EXTernal:FILTer:AUTO	23
:DM:EXTernal:POLarity	24
:DM:EXTernal:SOURce	24

Contents

:DM:IQADjustment:BBG:QSKew	25
:DM:IQADjustment:EXTernal:COFFset	26
:DM:IQADjustment:EXTernal:DIOFFset	26
:DM:IQADjustment:EXTernal:DQOFFset	27
:DM:IQADjustment:EXTernal:GAIN	27
:DM:IQADjustment:EXTernal:IOFFset	27
:DM:IQADjustment:EXTernal:IQATten	28
:DM:IQADjustment:EXTernal:QOFFset	28
:DM:IQADjustment:GAIN	29
:DM:IQADjustment:IOFFset	29
:DM:IQADjustment:QOFFset	30
:DM:IQADjustment:QSKew	30
:DM:IQADjustment:SKEW	31
:DM:IQADjustment:SKEW:Path	32
:DM:IQADjustment[:STATe]	32
:DM:MODulation:FILTer	32
:DM:MODulation:FILTer:AUTO	33
:DM:MODulation:ATTen	33
:DM:MODulation:ATTen:AUTO	34
:DM:POLarity[:ALL]	34
:DM:SKEW:PATH	35
:DM:SKEW[:STATe]	35
:DM:SOURce	35
:DM:SRATio	36
:DM:STATe	37
Frequency Subsystem ([:SOURce])	38
:FREQuency:CHANnels:BAND	38
:FREQuency:CHANnels:NUMBer	40
:FREQuency:CHANnels[:STATe]	41
:FREQuency:FIXed	41
:FREQuency:MODE	42
:FREQuency:MULTiplier	42
:FREQuency:OFFSet	43
:FREQuency:OFFSet:STATe	43
:FREQuency:REFerence	43
:FREQuency:REFerence:STATe	44
:FREQuency:STARt	44
:FREQuency:STOP	45

:FREQUency:SYNThesis	45
:FREQUency[:CW]	46
:FREQUency[:CW]:STEP[:INCRement]	47
:PHASe:REFerence	47
:PHASe[:ADJust]	47
:ROSCillator:SOURce	47
:ROSCillator:SOURce:AUTO	48
List/Sweep Subsystem ([:SOURce])	49
:LIST:DIRection	50
:LIST:DWELl	50
:LIST:DWELl:POINts	51
:LIST:DWELl:TYPE	51
:LIST:FREQUency	51
:LIST:FREQUency:POINts	52
:LIST:MANual	52
:LIST:MODE	53
:LIST:POWer	53
:LIST:POWer:POINts	53
:LIST:RETRace	54
:LIST:TRIGger:SOURce	54
:LIST:TYPE	55
:LIST:TYPE:LIST:INITialize:FSTep	55
:LIST:TYPE:LIST:INITialize:PRESet	56
:SWEep:DWELl	56
:SWEep:POINts	57
Power Subsystem ([:SOURce]:POWer)	58
:ALC:BANDwidth BWIth	58
:ALC:BANDwidth	59
:ALC:LEVel	60
:ALC:SEARch	60
:ALC:SEARch:REFerence	61
:ALC:SEARch:SPAN:START	61
:ALC:SEARch:SPAN:STOP:SPAN:STOP	61
:ALC:SEARch:SPAN:TYPE	62
:ALC:SEARch:SPAN[:STATe]	62
:ALC[:STATe]	62
:ALTErnate:AMPLitude	63
:ALTErnate:MANual	63

Contents

:ALternate:STATe	64
:ALternate:TRIGger[:SOURce]	64
:ATTenuation	65
:ATTenuation:AUTO	65
:MODE	66
:REFerence	66
:REFerence:STATe	67
:STARt	67
:STOP	68
[:LEVel][:IMMediate]:OFFSet	68
[:LEVel][:IMMediate][:AMPLitude]	69
[:LEVel][:IMMediate][:AMPLitude]:STEP	69
3. System Commands	71
Calibration Subsystem (:CALibration)	72
:DCFM	72
:IQ	72
:IQ:DC	72
:IQ:DEFault	73
:IQ:FULL	73
:IQ:STARt	74
:IQ:STOP	74
Communication Subsystem (:SYSTem:COMMunicate)	75
:GPIB:ADDRess	75
:GTLocal	75
:LAN:CONFig	75
:LAN:GATEway	76
:LAN:HOSTName	76
:LAN:IP	76
:LAN:SUBNet	77
:PMETer:ADDRess	77
:PMETer:CHANnel	77
:PMETer:IDN	78
:PMETer:TIMEout	78
:SERial:BAUD	79
:SERial:ECHO	79
:SERial:RESet	79
:SERial:TOUT	80

Diagnostic Subsystem (:DIAGnostic[:CPU]:INFORmation)	81
:BOARDs	81
:CCOunt:ATTenuator	81
:CCOunt:PON	81
:CCOunt:PROTection	81
:DISPlay:OTIME	82
:LIcense:AUXiliary	82
:LIcense:WAVEform	82
:OPTions	83
:OPTions:DETail	83
:OTIME	83
:REVision	83
:SDATe	84
:WLIcence[:VALue]	84
Display Subsystem (:DISPlay)	85
:ANNotation:AMPLitude:UNIT	85
:ANNotation:CLOCK:DATE:FORMat	85
:ANNotation:CLOCK[:STATe]	85
:BRIGHtness	86
:CAPTure	86
:CONTRast	86
:INVerse	87
:REMote	87
[:WINDow][:STATe]	87
IEEE 488.2 Common Commands	88
*CLS	88
*ESE	88
*ESE?	88
*ESR?	89
*IDN?	89
*OPC	89
*OPC?	90
*OPT?	90
*PSC	90
*PSC?	90
*RCL	90
*RST	91
*SAV	91

Contents

*SRE	91
*SRE?	92
*STB?	92
*TRG	92
*TST?	92
*WAI	93
Memory Subsystem (:MEMory)	94
:CATalog:BINary	94
:CATalog:BIT	94
:CATalog:CDMa	95
:CATalog:CDMA	95
:CATalog:DMOD	95
:CATalog:DWCDma	96
:CATalog:FCDMa	96
:CATalog:FIR	97
:CATalog:FSK	97
:CATalog:IQ	98
:CATalog:LIST	98
:CATalog:MCDMa	99
:CATalog:MDMod	99
:CATalog:MDWCdma	100
:CATalog:MFCdma	100
:CATalog:MTONE	101
:CATalog:RCDMa	101
:CATalog:SEQ	102
:CATalog:SHApe	102
:CATalog:STATe	103
:CATalog:UFLT	103
:CATalog:UWCDma	104
:CATalog[:ALL]	104
:COPY[:NAME]	105
:DATA	105
:DATA:APPend	106
:DATA:BIT	107
:DATA:FIR	108
:DATA:FSK	109
:DATA:IQ	110
:DATA:PRAM:FILE:BLOCK	112

:DATA:PRAM:FILE:LIST	113
:DATA:PRAM	114
:DATA:PRAM:BLOCK	114
:DATA:PRAM:LIST	114
:DATA:SHAPE	114
:DATA:SHAPE	115
:DATA:UNPRotected	116
:DELeTe:ALL	117
:DELeTe:BINary	118
:DELeTe:BIT	118
:DELeTe:CDMa	118
:DELeTe:CDMA	118
:DELeTe:DMOD	118
:DELeTe:DWCDma	119
:DELeTe:FCDMa	119
:DELeTe:FIR	119
:DELeTe:FSK	119
:DELeTe:IQ	119
:DELeTe:LIST	120
:DELeTe:MCDMa	120
:DELeTe:MDMod	120
:DELeTe:MDWCdma	120
:DELeTe:MFCdma	120
:DELeTe:MTONE	121
:DELeTe:RCDMa	121
:DELeTe:SEQ	121
:DELeTe:SHAPE	121
:DELeTe:STATe	121
:DELeTe:UFLT	122
:DELeTe:UWCDma	122
:DELeTe[:NAME]	122
:FREE[:ALL]	122
:LOAD:LIST	123
:MOVE	123
:STATe:COMMeNt	123
:STORe:LIST	123
Mass Memory Subsystem (:MMEMory)	124
:CATalog	124

Contents

:COPY	124
:DATA	125
:DELEte:NVWFm	125
:DELEte:WFM	125
:DELEte:WFM1	125
:DELEte[:NAME]	126
:HEADer:CLEar	126
:HEADer:DESCRiption	126
:LOAD:LIST	127
:MOVE	127
:STORE:LIST	127
Output Subsystem (:OUTPut)	128
:BLANKing:AUTO	128
:BLANKing:STATe	128
:MODulation[:STATe]	129
[:STATe]	129
Route Subsystem (:ROUte:HARDware:DGENerator)	130
:INPut:BPOLarity	130
:INPut:CPOLarity	130
:INPut:DPOLarity	131
:INPut:SPOLarity	131
:IPOLarity:BGATe	131
:IPOLarity:CLOCK	132
:IPOLarity:DATA	132
:IPOLarity:SSYNc	132
:OPOLarity:CLOCK	133
:OPOLarity:DATA	133
:OPOLarity:SSYNc	134
:OUTPut:CPOLarity	134
:OUTPut:DCS[:STATe]	135
:OUTPut:DPOLarity	135
:OUTPut:SPOLarity	135
Status Subsystem (:STATus)	136
:OPERation:BASeband:CONDition	136
:OPERation:BASeband:ENABle	136
:OPERation:BASeband:NTRansition	137
:OPERation:BASeband:PTRansition	137
:OPERation:BASeband[:EVENT]	138

:OPERation:CONDition	138
:OPERation:ENABle	139
:OPERation:NTRansition	139
:OPERation:PTRansition	140
:OPERation[:EVENT]	140
:PRESet	140
:QUEStionable:BERT:CONDition	141
:QUEStionable:BERT:ENABle	141
:QUEStionable:BERT:NTRansition	142
:QUEStionable:BERT:PTRansition	142
:QUEStionable:BERT[:EVENT]	143
:QUEStionable:CALibration:CONDition	143
:QUEStionable:CALibration:ENABle	143
:QUEStionable:CALibration:NTRansition	144
:QUEStionable:CALibration:PTRansition	144
:QUEStionable:CALibration[:EVENT]	145
:QUEStionable:CONDition	145
:QUEStionable:ENABle	146
:QUEStionable:FREQuency:CONDition	146
:QUEStionable:FREQuency:ENABle	146
:QUEStionable:FREQuency:NTRansition	147
:QUEStionable:FREQuency:PTRansition	147
:QUEStionable:FREQuency[:EVENT]	147
:QUEStionable:MODulation:CONDition	148
:QUEStionable:MODulation:ENABle	148
:QUEStionable:MODulation:NTRansition	149
:QUEStionable:MODulation:PTRansition	149
:QUEStionable:MODulation[:EVENT]	149
:QUEStionable:NTRansition	150
:QUEStionable:POWer:CONDition	150
:QUEStionable:POWer:ENABle	151
:QUEStionable:POWer:NTRansition	151
:QUEStionable:POWer:PTRansition	151
:QUEStionable:POWer[:EVENT]	152
:QUEStionable:PTRansition	152
:QUEStionable[:EVENT]	153
System Subsystem (:SYSTem)	154
:CAPability	154

Contents

:DATE	154
:ERRor[:NEXT]	155
:ERRor:SCPI[:SYNTax]	155
:FILESystem:SAFEmode	155
:HELP:MODE	156
:IDN	156
:LANGUage	156
:LICense:EXTernal:LIST	157
:OPT	157
:PON:TYPE	158
:PRESet	158
:PRESet:ALL	158
:PRESet:LANGUage	159
:PRESet:PERSistent	159
:PRESet:PN9	159
:PRESet:TYPE	160
:PRESet[:USER]:SAVE	160
:SECurity:DISPlay	160
:SECurity:ERASeall	161
:SECurity:LEVel	161
:SECurity:LEVel:STATe	162
:SECurity:OVERwrite	163
:SECurity:SANitize	163
:SSAVer:DELay	164
:SSAVer:MODE	164
:SSAVer:STATe	164
:TIME	165
:VERSiOn	165
Trigger Subsystem	166
:ABORt	166
:INITiate:CONTinuous[:ALL]	166
:INITiate[:IMMediate][:ALL]	167
:TRIGger:OUTPut:POLarity	167
:TRIGger[:SEQuence]:SLOPe	168
:TRIGger[:SEQuence]:SOURce	168
:TRIGger[:SEQuence][:IMMediate]	169
Unit Subsystem (:UNIT)	170
:POWer	170

4. Analog Commands	171
Amplitude Modulation Subsystem ([:SOURce])	172
:AM[1]2....	172
:AM:INTErnal:FREQuency:STEP[:INCRement]	172
:AM:WIDeband:STATe.	173
:AM[1]2:EXTErnal[1]2:COUPLing	173
:AM[1]2:INTErnal[1]:FREQuency	174
:AM[1]2:INTErnal[1]:FREQuency:ALTErnate.	174
:AM[1]2:INTErnal[1]:FREQuency:ALTErnate:AMPLitude:PERCent.	175
:AM[1]2:INTErnal[1]:FUNCTion:SHAPE.	175
:AM[1]2:INTErnal[1]:SWEep:TIME	175
:AM[1]2:INTErnal[1]:SWEep:TRIGger.	176
:AM[1]2:SOURce.	176
:AM[1]2:STATe	177
:AM[1]2[:DEPT]h]	177
:AM[1]2[:DEPT]h]:TRACk	178
:AM[:DEPT]h]:STEP[:INCRement]	178
Frequency Modulation Subsystem ([:SOURce])	179
:FM[1]2....	179
:FM:INTErnal:FREQuency:STEP[:INCRement]	180
:FM[1]2:EXTErnal[1]2:COUPLing	180
:FM[1]2:INTErnal[1]:FREQuency	181
:FM[1]2:INTErnal[1]:FREQuency:ALTErnate	181
:FM[1]2:INTErnal[1]:FREQuency:ALTErnate:AMPLitude:PERCent.	182
:FM[1]2:INTErnal[1]:FUNCTion:SHAPE	182
:FM[1]2:INTErnal[1]:SWEep:TIME	183
:FM[1]2:INTErnal[1]:SWEep:TRIGger	183
:FM[1]2:SOURce	184
:FM[1]2:STATe.	184
:FM[1]2[:DEV]iation]	185
:FM[1]2[:DEV]iation]:TRACk	185
Low Frequency Output Subsystem ([:SOURce]:LFOutput)	186
:AMPLitude.	186
:FUNCTion[1]:FREQuency	186
:FUNCTion[1]:FREQuency:ALTErnate	187
:FUNCTion[1]:FREQuency:ALTErnate:AMPLitude:PERCent.	187
:FUNCTion[1]:PERiod.	188
:FUNCTion[1]:PWIDth	188

Contents

:FUNctIon[1]:SHApe	189
:FUNctIon[1]:SWEep:TIME	189
:FUNctIon[1]:SWEep:TRIGger	189
:SOURce	190
:STATe	190
Phase Modulation Subsystem ([:SOURce])	191
:PM[1]2.....	191
:PM:INtErnal:FREQuency:STEP[:INCRement]	192
:PM[1]2:BANDwidth BWIDth	192
:PM[1]2:EXtErnal[1]:COUPLing	193
:PM[1]2:INtErnal[1]:FREQuency	193
:PM[1]2:INtErnal[1]:FREQuency:ALtErnate	194
:PM[1]2:INtErnal[1]:FREQuency:ALtErnate:AMPLitude:PERCent	194
:PM[1]2:INtErnal[1]:FUNctIon:SHApe	195
:PM[1]2:INtErnal[1]:SWEep:TIME	195
:PM[1]2:INtErnal[1]:SWEep:TRIGger	195
:PM[1]2:SOURce	196
:PM[1]2:STATe	196
:PM[1]2[:DEVIation]	197
:PM[1]2[:DEVIation]:TRACk	197
:PM[:DEVIation]:STEP[:INCRement]	198
Pulse Modulation Subsystem ([:SOURce]:PULM)	199
:INtErnal[1]:FREQuency	199
:INtErnal[1]:FREQuency:STEP	199
:INtErnal[1]:FUNctIon:SHApe	200
:INtErnal[1]:PERiod	200
:INtErnal[1]:PERiod:STEP[:INCRement]	200
:INtErnal[1]:PWIDth	201
:INtErnal[1]:PWIDth:STEP	201
:SOURce	202
:STATe	202

5. Component Test Digital Commands 203

All Subsystem–Option 001/601 or 002/602 ([:SOURce])	204
:RADio:ALL:OFF	204
AWGN ARB Subsystem–Option 403 ([:SOURce]:RADio:AWGN:ARB)	205
:BWIDth	205
:IQ:EXtErnal:FILTer	205

:IQ:EXternal:FILTer:AUTO	206
:HEADer:CLEar	206
:HEADer:SAVE	206
:IQ:MODulation:ATTen	207
:IQ:MODulation:ATTen:AUTO	207
:IQ:MODulation:FILTer	208
:IQ:MODulation:FILTer:AUTO	208
:MDEStination:AAMPLitude	209
:MDEStination:ALCHold	209
:MDEStination:PULSe	210
:MPOLarity:MARKer1 2 3 4	212
:LENgth	212
:REFeRence:EXTernal:FREQuency	212
:REFeRence[:SOURce]	213
:SCLock:RATE	213
:SEED	214
[:STATe]	214
CDMA ARB Subsystem–Option 401 ([:SOURce]:RADio:CDMA:ARB)	215
:CLIPping:I	215
:CLIPping:POSition	215
:CLIPping:Q	215
:CLIPping:TYPE	216
:CLIPping[:IJQ]	216
:CRATe	216
:IQ:EXTernal:FILTer	217
:IQ:EXTernal:FILTer:AUTO	217
:FILTer	218
:FILTer:ALPHa	219
:FILTer:BBT	219
:FILTer:CHANnel	220
:HEADer:CLEar	220
:HEADer:SAVE	220
:IQMap	221
:IQ:MODulation:ATTen	221
:IQ:MODulation:ATTen:AUTO	221
:IQ:MODulation:FILTer	222
:IQ:MODulation:FILTer:AUTO	222
:MDEStination:AAMPLitude	222

Contents

:MDEStination:ALCHold	223
:MDEStination:PULSe	224
:MPOLarity:MARKer1 2 3 4	226
:OSAMple	226
:REFeRence:EXTernal:FREQuency	226
:REFeRence[:SOURce]	227
:RETRigger	227
:SCLock:RATE	228
:SETup	228
:SETup:CHANnel	229
:SETup:MCARrier	230
:SETup:MCARrier:STORE	231
:SETup:MCARrier:TABLE	231
:SETup:STORE	232
:TRIGger:TYPE	233
:TRIGger:TYPE:CONTInuous[:TYPE]	234
:TRIGger:TYPE:GATE:ACTive	235
:TRIGger[:SOURce]	235
:TRIGger[:SOURce]:EXTernal:DELay	236
:TRIGger[:SOURce]:EXTernal:DELay:STATe	237
:TRIGger[:SOURce]:EXTernal:SLOPe	237
:TRIGger[:SOURce]:EXTernal[:SOURce]	238
:WLENgth	238
[:STATe]	239
CDMA2000 ARB Subsystem–Option 401 ([:SOURce]:RADio:CDMA2000:ARB)	240
:CLIPping:I	240
:CLIPping:POSition	240
:CLIPping:Q	240
:CLIPping:TYPE	241
:CLIPping[:IJQ]	241
:IQ:EXTernal:FILTer	241
:IQ:EXTernal:FILTer:AUTO	242
:FILTer	242
:FILTer:ALPHa	243
:FILTer:BBT	244
:FILTer:CHANnel	244
:HEADer:CLEar	245
:HEADer:SAVE	245

:IQ:MODulation:ATTen	245
:IQ:MODulation:ATTen:AUTO	246
:IQ:MODulation:FILTer	246
:IQ:MODulation:FILTer:AUTO	246
:IQMap	247
:LINK	247
:LINK:FORWard:SETup	247
:LINK:FORWard:SETup:MCARrier	248
:LINK:FORWard:SETup:MCARrier:STORE	249
:LINK:FORWard:SETup:MCARrier:TABLE	249
:LINK:FORWard:SETup:MCARrier:TABLE:NCARriers	250
:LINK:FORWard:SETup:STORE	251
:LINK:FORWard:SETup:TABLE:APPLy	251
:LINK:FORWard:SETup:TABLE:CHANnel	252
:LINK:FORWard:SETup:TABLE:NCHannels	253
:LINK:FORWard:SETup:TABLE:PADJust	253
:LINK:REVerse:RCONfig	253
:LINK:REVerse:SETup	254
:LINK:REVerse:SETup:STORE	254
:LINK:REVerse:SETup:TABLE:APPLy	255
:LINK:REVerse:SETup:TABLE:CHANnel	255
:LINK:REVerse:SETup:TABLE:NCHannels	256
:LINK:REVerse:SETup:TABLE:PADJust	256
:MDEStination:AAMPLitude	257
:MDEStination:ALCHold	257
:MDEStination:PULSe	258
:MPOLarity:MARKer1 2 3 4	260
:REFerence:EXTernal:FREQuency	260
:REFerence[:SOURce]	260
:RETRigger	261
:REVision	261
:SCLock:RATE	262
:SPReading:RATE	262
:SPReading:TYPE	263
:SPReading:TYPE:MCARrier:SPACing	263
:TRIGger:TYPE	263
:TRIGger:TYPE:CONtinuous[:TYPE]	265
:TRIGger:TYPE:GATE:ACTive	266

Contents

:TRIGger[:SOURce]	266
:TRIGger[:SOURce]:EXTernal:DELay	267
:TRIGger[:SOURce]:EXTernal:DELay:STATe	268
:TRIGger[:SOURce]:EXTernal:SLOPe	268
:TRIGger[:SOURce]:EXTernal[:SOURce]	269
[:STATe]	269
Dmodulation Subsystem–Option 001/601 or 002/602 ([:SOURce]:RADio:DMODulation:ARB)	270
:IQ:EXTernal:FILTer	270
:IQ:EXTernal:FILTer:AUTO	270
:FILTer	271
:FILTer:ALPHa	272
:FILTer:BBT	272
:FILTer:CHANnel	273
:HEADer:CLEar	273
:HEADer:SAVE	273
:IQ:MODulation:ATTen	274
:IQ:MODulation:ATTen:AUTO	274
:IQ:MODulation:FILTer	275
:IQ:MODulation:FILTer:AUTO	275
:MDEStination:AAMPLitude	276
:MDEStination:ALCHold	276
:MDEStination:PULSe	277
:MODulation:FSK[:DEViation]	279
:MODulation[:TYPE]	279
:MPOLarity:MARKer1 2 3 4	280
:REFerence:EXTernal:FREQuency	280
:REFerence[:SOURce]	281
:RETRigger	281
:SCLock:RATE	282
:SETup	282
:SETup:MCARrier	283
:SETup:MCARrier:PHASe	283
:SETup:MCARrier:STORE	284
:SETup:MCARrier:TABLE	284
:SETup:MCARrier:TABLE:NCARriers	285
:SETup:STORE	285
:SRAtE	286
:TRIGger:TYPE	287

:TRIGger:TYPE:CONTInuous[:TYPE]	288
:TRIGger:TYPE:GATE:ACTive	289
:TRIGger[:SOURce]	290
:TRIGger[:SOURce]:EXTernal:DELay	291
:TRIGger[:SOURce]:EXTernal:DELay:STATe	291
:TRIGger[:SOURce]:EXTernal:SLOPe	292
:TRIGger[:SOURce]:EXTernal[:SOURce]	292
[:STATe]	293
Dual ARB Subsystem–Option 001/601 or 002/602 ([:SOURce]:RADio:ARB)	294
:CLIPping	294
:FILTer:ALPHa	294
:FILTer:BBT	295
:FILTer:CHANnel	295
:FILTer:TYPE	296
:FILTer[:STATe]	297
:GENerate:SINE	297
:HEADer:CLEar	298
:HEADer:NOISe:RMS[:OVERride]	298
:HEADer:RMS	299
:HEADer:SAVE	301
:HCRest[:STATe]	301
:IQ:EXTernal:FILTer	302
:IQ:EXTernal:FILTer:AUTO	302
:IQ:MODulation:ATTen	302
:IQ:MODulation:ATTen:AUTO	303
:IQ:MODulation:FILTer	303
:IQ:MODulation:FILTer:AUTO	304
:MARKer:CLEar	304
:MARKer:CLEar:ALL	305
:MARKer:ROtate	306
:MARKer:[SET]	306
:MDEStination:AAMPLitude	309
:MDEStination:ALCHold	309
:MDEStination:PULSe	310
:MPOLarity:MARKer1 2 3 4	312
:NOISe:BFACtor	312
:NOISe:CBWidth	313
:NOISe:CN	313

Contents

:NOISe[:STATe]	314
:REFerence:EXTernal:FREQuency	314
:REFerence[:SOURce]	315
:RETRigger	315
:RSCAling	316
:SCAling	316
:SCLock:RATE	317
:SEQuence	317
:TRIGger:TYPE	319
:TRIGger:TYPE:CONTinuous[:TYPE]	321
:TRIGger:TYPE:GATE:ACTive	321
:TRIGger:TYPE:SADVance[:TYPE]	322
:TRIGger:TYPE:SADVance[:TYPE]	322
:TRIGger[:SOURce]	324
:TRIGger[:SOURce]:EXTernal:DELay:SAMPles	325
:TRIGger[:SOURce]:EXTernal:DELay:STATe OFF ON 1 0	325
:TRIGger[:SOURce]:EXTernal:DELay:STATe	325
:TRIGger[SOURce]:EXTernal:DELay[:TIME]	326
:TRIGger[:SOURce]:EXTernal:SLOPe	326
:TRIGger[:SOURce]:EXTernal[:SOURce]	327
:WAVeform	327
:WAVeform:NHEAders	328
[:STATe]	328
Multitone Subsystem—Option 001/601 or 002/602 ([:SOURce]:RADio:MTONe:ARB)	330
Creating a Multitone Waveform	330
:HEADer:CLear	330
:HEADer:SAVE	330
:IQ:EXTernal:FILTer	331
:IQ:EXTernal:FILTer:AUTO	331
:IQ:MODulation:ATTen	332
:IQ:MODulation:ATTen:AUTO	332
:IQ:MODulation:FILTer	333
:IQ:MODulation:FILTer:AUTO	333
:MDESTination:AAMPliitude	333
:MDESTination:ALCHold	334
:MDESTination:PULSe	335
:MPOLarity:MARKer1 2 3 4	337
:REFerence:EXTernal:FREQuency	337

:REfERENCE[:SOURce]	337
:ROW	338
:RSCAling	339
:SCLock:RATE	339
:SETup	340
:SETup:STORe	340
:SETup:TABLE	340
:SETup:TABLE:FSPacing	341
:SETup:TABLE:NTONes	341
:SETup:TABLE:PHASe:INITialize	342
:SETup:TABLE:PHASe:INITialize:SEED	342
[:STATe]	343
Wideband CDMA ARB Subsystem–Option 400	
([:SOURce]:RADio:WCDMa:TGPP:ARB)	344
:CLIPping:I	344
:CLIPping:POSition	344
:CLIPping:Q	344
:CLIPping:TYPE	345
:CLIPping[:IJQ]	345
:CRATe	346
:FILTer	346
:FILTer:ALPHa	347
:FILTer:BBT	347
:FILTer:CHANnel	348
:HEADer:CLEAr	348
:HEADer:SAVE	348
:IQ:EXTernal:FILTer	348
:IQ:EXTernal:FILTer:AUTO	349
:IQMap	349
:IQ:MODulation:ATTen	350
:IQ:MODulation:ATTen:AUTO	350
:IQ:MODulation:FILTer	350
:IQ:MODulation:FILTer:AUTO	351
:LINK	351
:LINK:DOWN:OACP	351
:LINK:DOWN:SETup	352
:LINK:DOWN:SETup:MCARrier	353
:LINK:DOWN:SETup:MCARrier:CLIPping:I	355
:LINK:DOWN:SETup:MCARrier:CLIPping:Q	356

Contents

:LINK:DOWN:SETup:MCARrier:CLIPping:TYPE	356
:LINK:DOWN:SETup:MCARrier:CLIPping[:IJQ]	356
:LINK:DOWN:SETup:MCARrier:SCODE:AINCrement	357
:LINK:DOWN:SETup:MCARrier:STORE	357
:LINK:DOWN:SETup:MCARrier:TABLE	358
:LINK:DOWN:SETup:MCARrier:TABLE:NCARriers	360
:LINK:DOWN:SETup:MCARrier:TOFFset:AINCrement	360
:LINK:DOWN:SETup:STORE	360
:LINK:DOWN:SETup:TABLE:APPLY	361
:LINK:DOWN:SETup:TABLE:CHANnel	361
:LINK:DOWN:SETup:TABLE:NCHannels?	366
:LINK:DOWN:SETup:TABLE:PADJust	366
:LINK:DOWN:TFCI	366
:LINK:UP:OACP	367
:LINK:UP:SCRAMBLE	367
:LINK:UP:SDPDch	367
:LINK:UP:SETup	368
:LINK:UP:SETup:STORE	369
:LINK:UP:SETup:TABLE:APPLY	369
:LINK:UP:SETup:TABLE:CHANnel	369
:LINK:UP:SETup:TABLE:GUNit	371
:LINK:UP:SETup:TABLE:NCHannel	371
:LINK:UP:TFCI	371
:MDEStination:AAMPLitude	372
:MDEStination:ALCHold	372
:MDEStination:PULSe	373
:MPOLarity:MARKer1 2 3 4	375
:REFerence:EXTernal:FREQuency	375
:REFerence[:SOURce]	375
:RETRigger	376
:REVision	376
:SCLock:RATE	377
:TRIGger:TYPE	377
:TRIGger:TYPE:CONTinuous[:TYPE]	379
:TRIGger:TYPE:GATE:ACTive	379
:TRIGger[:SOURce]	380
:TRIGger[:SOURce]:EXTernal:DELay	381
:TRIGger[:SOURce]:EXTernal:DELay:STATe	381

:TRIGger[:SOURce]:EXTernal:SLOPe	382
:TRIGger[:SOURce]:EXTernal[:SOURce]	382
[:STATe]	383
6. Digital Signal Interface Module Commands	385
Digital Subsystem—Option 003 and 004 ([:SOURce])	386
:DIGital:CLOCK:CPS 1 2 4	386
:DIGital:CLOCK:PHASe	386
:DIGital:CLOCK:POLarity	387
:DIGital:CLOCK:RATE	388
:DIGital:CLOCK:REFerence:FREQuency	388
:DIGital:CLOCK:SKEW	389
:DIGital:CLOCK:SOURce	389
:DIGital:DATA:ALIGNment	390
:DIGital:DATA:BORDer	390
:DIGital:DATA:DIRection	391
:DIGital:DATA:IGain	391
:DIGital:DATA:INEGate	392
:DIGital:DATA:IOFFset	392
:DIGital:DATA:IQSWap	393
:DIGital:DATA:NFORmat	393
:DIGital:DATA:POLarity:FRAMe	393
:DIGital:DATA:POLarity:IQ	394
:DIGital:DATA:QGain	394
:DIGital:DATA:QNEGate	395
:DIGital:DATA:QOFFset	396
:DIGital:DATA:ROTation	396
:DIGital:DATA:SCALing	397
:DIGital:DATA:SIZE	397
:DIGital:DATA:STYPE	398
:DIGital:DATA:TYPE	398
:DIGital:DIAGnostic:LOOPback	399
:DIGital:LOGic[:TYPE]	399
:DIGital:PCONfig	400
:DIGital:PRESet:PTHROUGH	401
:DIGital[:STATe]	401
7. Bit Error Rate Test (BERT) Commands	403

Contents

Calculate Subsystem–Option UN7 and 300 (:CALCulate:BERT)	404
:BTS:LOOPback:EDGE:ETCH:F43:COMParator:CRITeria:ERATe	404
:BTS:LOOPback:EDGE:ETCH:F43:COMParator:CRITeria[:SElect]	404
:BTS:LOOPback:EDGE:MCS5:COMParator:CRITeria:ERATe	405
:BTS:LOOPback:EDGE:MCS5:COMParator:CRITeria[:SElect]	405
:BTS:LOOPback:EDGE:MCS9:COMParator:CRITeria:ERATe	405
:BTS:LOOPback:EDGE:MCS9:COMParator:CRITeria[:SElect]	406
:BTS:LOOPback:EDGE:UNCoded:COMParator:CRITeria:ERATe	406
:BTS:LOOPback:EDGE:UNCoded:COMParator:CRITeria[:SElect]	407
:BTS:LOOPback:GSM:CS1:COMParator:CRITeria:ERATe	407
:BTS:LOOPback:GSM:CS1:COMParator:CRITeria[:SElect]	408
:BTS:LOOPback:GSM:CS4:COMParator:CRITeria:ERATe	408
:BTS:LOOPback:GSM:CS4:COMParator:CRITeria[:SElect]	408
:BTS:LOOPback:GSM:MCS1:COMParator:CRITeria:ERATe	409
:BTS:LOOPback:GSM:MCS1:COMParator:CRITeria[:SElect]	409
:BTS:LOOPback:GSM:COMParator:CRITeria:CIB	410
:BTS:LOOPback:GSM:COMParator:CRITeria:CII	410
:BTS:LOOPback:GSM:COMParator:CRITeria:FERasure	410
:BTS:LOOPback:GSM:COMParator:CRITeria[:SElect]	411
[:BASeband]:COMParator:MODE	411
[:BASeband]:COMParator:THReshold	412
[:BASeband]:COMParator[:STATe]	412
[:BASeband]:DISPlay:MODE:	413
[:BASeband]:DISPlay:UPDate:	413
Data Subsystem–Option UN7 and 300 (:DATA)	414
:BERT:BTS:LOOPback:EDGE:ETCH:F43[:DATA]	414
:BERT:BTS:LOOPback:EDGE:MCS5[:DATA]	415
:BERT:BTS:LOOPback:EDGE:MCS9[:DATA]	416
:BERT:BTS:LOOPback:EDGE:UNCoded[:DATA]	416
:BERT:BTS:LOOPback:GSM[:DATA]	416
:BERT:BTS:LOOPback:GSM:CS1[:DATA]	418
:BERT:BTS:LOOPback:GSM:CS4[:DATA]	419
:BERT:BTS:LOOPback:GSM:MCS1[:DATA]	419
:BERT:AUXout	419
[:DATA]	421
Input Subsystem–Option UN7 (:INPut:BERT[: BASeband])	422
:CGATe:DELay:CLOCK	4 2 2
:CGATe:DELay:MODE	4 2 2

:CGATe:DELAy:TIME	423
:CGATe:DELAy[:STATe]	423
:CGATe:POLarity	424
:CGATe[:STATe]	424
:CLOCK:DELAy:RESolution	424
:CLOCK:DELAy:TIME	425
:CLOCK:DELAy[:STATe]	425
:CLOCK:POLarity	426
:DATA:POLarity	426
:IMPedance	426
:THReshold	427
Measure Subsystem–Option 300 (:MEASure[:SCALar]:BERT:BTS:LOOPback)	428
:EDGE:MCS5[:SENSitivity]	428
:EDGE:MCS9[:SENSitivity]	428
:EDGE:UNCoded[:SENSitivity]	429
:GSM[:SENSitivity]	430
Sense Subsystem–Options UN7 and 300 ([:SOURce]:SENSe:BERT)	431
:BTS:LOOPback:EDGE:ETCH:F43:BLOCK:COUNT	431
:BTS:LOOPback:EDGE:ETCH:F43:CONTain	431
:BTS:LOOPback:EDGE:ETCH:F43:STOP:CRITeria:EBLock	432
:BTS:LOOPback:EDGE:ETCH:F43:STOP:CRITeria[:SElect]	432
:BTS:LOOPback:EDGE:FTRigger:EXTernal:DELAy	433
:BTS:LOOPback:EDGE:FTRigger:EXTernal:POLarity	433
:BTS:LOOPback:EDGE:FTRigger[SElect]	434
:BTS:LOOPback:EDGE:MCS5:BLOCK:COUNT	434
:BTS:LOOPback:EDGE:MCS5:CONTain	435
:BTS:LOOPback:EDGE:MCS5:ESENSitivity	435
:BTS:LOOPback:EDGE:MCS5:HAMPLitude	435
:BTS:LOOPback:EDGE:MCS5:LAMPLitude	436
:BTS:LOOPback:EDGE:MCS5:PAMPLitude	436
:BTS:LOOPback:EDGE:MCS5:SBLOCK:COUNT	436
:BTS:LOOPback:EDGE:MCS5:SBLOCK:INITial	437
:BTS:LOOPback:EDGE:MCS5:STOP:CRITeria:EBLock	437
:BTS:LOOPback:EDGE:MCS5:STOP:CRITeria[:SElect]	437
:BTS:LOOPback:EDGE:MCS9:BLOCK:COUNT	438
:BTS:LOOPback:EDGE:MCS9:CONTain	438
:BTS:LOOPback:EDGE:MCS9:ESENSitivity	438
:BTS:LOOPback:EDGE:MCS9:HAMPLitude	439

Contents

:BTS:LOOPback:EDGE:MCS9:LAMPlitude	439
:BTS:LOOPback:EDGE:MCS9:PAMPlitude	440
:BTS:LOOPback:EDGE:MCS9:SBLock:COUNT	440
:BTS:LOOPback:EDGE:MCS9:SBLock:INITial	440
:BTS:LOOPback:EDGE:MCS9:STOP:CRITeria:EBLock	441
:BTS:LOOPback:EDGE:MCS9:STOP:CRITeria[:SElect]	441
:BTS:LOOPback:EDGE:MEASurement:STOP	441
:BTS:LOOPback:EDGE:MEASurement:TSLot	442
:BTS:LOOPback:EDGE:MEASurement[:MODE]	442
:BTS:LOOPback:EDGE:SINVert	443
:BTS:LOOPback:EDGE:SYNC:AGain	443
:BTS:LOOPback:EDGE:SYNC:RF	443
:BTS:LOOPback:EDGE:SYNC[:SOURce]	444
:BTS:LOOPback:EDGE:TRIGger[:SOURce]	444
:BTS:LOOPback:EDGE:ULINK:OFFSet	445
:BTS:LOOPback:EDGE:UNCoded:BIT:COUNT	445
:BTS:LOOPback:EDGE:UNCoded:ESEnsitivity	445
:BTS:LOOPback:EDGE:UNCoded:HAMPlitude	446
:BTS:LOOPback:EDGE:UNCoded:LAMPlitude	446
:BTS:LOOPback:EDGE:UNCoded:PAMPlitude	447
:BTS:LOOPback:EDGE:UNCoded:SBIT:COUNT	447
:BTS:LOOPback:EDGE:UNCoded:SBIT:INITial	447
:BTS:LOOPback:EDGE:UNCoded:STOP:CRITeria:EBIT	448
:BTS:LOOPback:EDGE:UNCoded:STOP:CRITeria[:SElect]	448
:BTS:LOOPback:EDGE[:STATe]	448
:BTS:LOOPback:GSM:CS1:BLOCK:COUNT	449
:BTS:LOOPback:GSM:CS1:CONTain	449
:BTS:LOOPback:GSM:CS1:STOP:CRITeria:EBLock	450
:BTS:LOOPback:GSM:CS1:STOP:CRITeria[:SElect]	450
:BTS:LOOPback:GSM:CS4:BLOCK:COUNT	450
:BTS:LOOPback:GSM:CS4:CONTain	451
:BTS:LOOPback:GSM:CS4:STOP:CRITeria:EBLock	451
:BTS:LOOPback:GSM:CS4:STOP:CRITeria[:SElect]	452
:BTS:LOOPback:GSM:ESEnsitivity	452
:BTS:LOOPback:GSM:FRAMe:CIB	452
:BTS:LOOPback:GSM:FRAMe:CII	452
:BTS:LOOPback:GSM:FRAMe:COUNT	453
:BTS:LOOPback:GSM:HAMPlitude	453

:BTS:LOOPback:GSM:LAMplitude	453
:BTS:LOOPback:GSM:MCS1:BLOCK:COUNT.	454
:BTS:LOOPback:GSM:MCS1:CONTain	454
:BTS:LOOPback:GSM:MCS1:STOP:CRITeria:EBLock.	454
:BTS:LOOPback:GSM:MCS1:STOP:CRITeria[:SElect]	455
:BTS:LOOPback:GSM:MEASurement:STOP	455
:BTS:LOOPback:GSM:MEASurement:TSLot.	455
:BTS:LOOPback:GSM:MEASurement[:MODE].	456
:BTS:LOOPback:GSM:PAMplitude.	456
:BTS:LOOPback:GSM:SFRame:COUNT	456
:BTS:LOOPback:GSM:SFRame:INITial	457
:BTS:LOOPback:GSM:SINVert	457
:BTS:LOOPback:GSM:STOP:CRITeria:CIB	457
:BTS:LOOPback:GSM:STOP:CRITeria:CII	458
:BTS:LOOPback:GSM:STOP:CRITeria:FERasure	458
:BTS:LOOPback:GSM:STOP:CRITeria[:SElect]	458
:BTS:LOOPback:GSM:SYNC:RF	459
:BTS:LOOPback:GSM:SYNC[:SOURce]	460
:BTS:LOOPback:GSM:TRIGger[:SOURce]	460
:BTS:LOOPback:GSM:ULINK:OFFSet	461
:BTS:LOOPback:GSM[:STATe]	461
[:BASeband]:PRBS:FUNCTion:SPIgnore:DATA.	461
[:BASeband]:PRBS:FUNCTion:SPIgnore[:STATe]	462
[:BASeband]:PRBS[:DATA].	462
[:BASeband]:RSYNc:THReshold.	462
[:BASeband]:RSYNc[:STATe]	463
[:BASeband]:STATe	463
[:BASeband]:STOP:CRITeria:EBIT	463
[:BASeband]:STOP:CRITeria[:SElect]	464
[:BASeband]:TBITs	464
[:BASeband]:TRIGger:BDELay.	465
[:BASeband]:TRIGger:BDELay:STATe.	465
[:BASeband]:TRIGger:COUNT.	465
[:BASeband]:TRIGger:POLarity	466
[:BASeband]:TRIGger[:SOURce]	466
8. Receiver Test Digital Commands.	467
All Subsystem–Option 001/601or 002/602 ([:SOURce]).	468

Contents

:RADio:ALL:OFF	468
AWGN Real-Time Subsystem–Option 403 ([:SOURce]:RADio:AWGN:RT)	469
:BWIDth	469
[:STATe]	469
Bluetooth Subsystem–Option 406 ([:SOURce]:RADio:BLUEtooth:ARB)	470
:AMADdr	470
:BDADdr	470
:BURSt[:STATe]	470
:CGDelay	471
:DATA	471
:IQ:EXTernal:FILTer	472
:IQ:EXTernal:FILTer:AUTO	472
:HEADer:CLEar	473
:HEADer:SAVE	473
:IMPairments	473
:IMPairments:AWGN	474
:IMPairments:AWGN:CNR	474
:IMPairments:AWGN:NSEed	475
:IMPairments:DDEVIation	475
:IMPairments:FDType	476
:IMPairments:FOFFset	476
:IMPairments:MINDEX	477
:IMPairments:STERror	478
:IQ:MODulation:ATTen	478
:IQ:MODulation:ATTen:AUTO	479
:IQ:MODulation:FILTer	479
:IQ:MODulation:FILTer:AUTO	480
:MDEStination:AAMPplitude	480
:MDEStination:ALCHold	480
:MDEStination:PULSe	481
:MPOLarity:MARKer1 2 3 4	481
:MPOLarity:MARKer1	481
:MPOLarity:MARKer2	482
:MPOLarity:MARKer3	482
:MPOLarity:MARKer4	482
:PACKet	482
:REFernce:EXTernal:FREQuency	483
:REFernce[:SOURce]	483

:RSYMBOLS	.484
:SLOCK:RATE	.484
[:STATE]	.484
CDMA2000 BBG Subsystem–Option 401 ([:SOURCE]:RADIO:CDMA2000[:BBG])	.485
:LMODE	.485
[:FORWARD]:BBLOCK	.486
[:FORWARD]:CHIPRATE	.486
[:FORWARD]:ESDELAY	.486
[:FORWARD]:FILTER	.487
[:FORWARD]:FILTER:ALPHA	.488
[:FORWARD]:FILTER:BBT	.488
[:FORWARD]:FILTER:CHANNEL	.488
[:FORWARD]:LCSTATE	.489
[:FORWARD]:FFCH:DATA	.489
[:FORWARD]:FFCH:DATA:FIX4	.490
[:FORWARD]:FFCH:EBNO	.490
[:FORWARD]:FFCH:FOFFSET	.491
[:FORWARD]:FFCH:LCMASK	.491
[:FORWARD]:FFCH:LCMASK:ESN	.492
[:FORWARD]:FFCH:LCMASK:HEADER	.492
[:FORWARD]:FFCH:POWER	.492
[:FORWARD]:FFCH:PRAMP	.493
[:FORWARD]:FFCH:PRTIME	.493
[:FORWARD]:FFCH:QOF	.493
[:FORWARD]:FFCH:RATE	.494
[:FORWARD]:FFCH:RCONFIG	.494
[:FORWARD]:FFCH:WALSH	.494
[:FORWARD]:FFCH[:STATE]	.495
[:FORWARD]:FPCH:DATA	.495
[:FORWARD]:FPCH:EBNO	.495
[:FORWARD]:FPCH:LCMASK	.496
[:FORWARD]:FPCH:LCMASK:F1	.496
[:FORWARD]:FPCH:LCMASK:F2	.496
[:FORWARD]:FPCH:LCMASK:F3	.497
[:FORWARD]:FPCH:MESSAGE	.497
[:FORWARD]:FPCH:POWER	.497
[:FORWARD]:FPCH:RATE	.498
[:FORWARD]:FPCH:WALSH	.498

Contents

[:FORWard]:FPCH[:STATe]	498
[:FORWard]:FPICH:ECNO	499
[:FORWard]:FPICH:POWEr	499
[:FORWard]:FPICH[:STATe]	500
[:FORWard]:FSCH[1]2:DATA	500
[:FORWard]:FSCH[1]2:DATA:FIX4	500
[:FORWard]:FSCH[1]2:EBNO	501
[:FORWard]:FSCH[1]2:FOFFset	501
[:FORWard]:FSCH[1]2:LCMask	502
[:FORWard]:FSCH[1]2:LCMask:ESN	502
[:FORWard]:FSCH[1]2:LCMask:HEADer	502
[:FORWard]:FSCH[1]2:POWEr	503
[:FORWard]:FSCH[1]2:QOF	503
[:FORWard]:FSCH[1]2:RATE	503
[:FORWard]:FSCH[1]2:RCONfig	504
[:FORWard]:FSCH[1]2:TCODE	504
[:FORWard]:FSCH[1]2:WALSh	504
[:FORWard]:FSCH[1]2[:STATe]	505
[:FORWard]:FSYNc:CFRequency	505
[:FORWard]:FSYNc:DAYLt	505
[:FORWard]:FSYNc:EBNO	506
[:FORWard]:FSYNc:ECFRequency	506
[:FORWard]:FSYNc:LPSec	507
[:FORWard]:FSYNc:LTMoff	507
[:FORWard]:FSYNc:MPREv	507
[:FORWard]:FSYNc:MSGType	508
[:FORWard]:FSYNc:NID	508
[:FORWard]:FSYNc:POWEr	508
[:FORWard]:FSYNc:PRATe	509
[:FORWard]:FSYNc:PREV	509
[:FORWard]:FSYNc:RESERVED	509
[:FORWard]:FSYNc:SID	510
[:FORWard]:FSYNc:STYPe	510
[:FORWard]:FSYNc:SYSTime	510
[:FORWard]:FSYNc:WALSh	511
[:FORWard]:FSYNc[:STATe]	511
[:FORWard]:NOISe:CN	511
[:FORWard]:NOISe[:STATe]	512

[:FORWard]:OCNS:EBNO	512
[:FORWard]:OCNS:POWer	513
[:FORWard]:OCNS:WALSh	514
[:FORWard]:OCNS[:STATe]	514
[:FORWard]:PADJust	514
[:FORWard]:POLarity	515
[:FORWard]:QPCH:CCI	515
[:FORWard]:QPCH:EBNO	515
[:FORWard]:QPCH:PI	516
[:FORWard]:QPCH:POWer	516
[:FORWard]:QPCH:RATE	517
[:FORWard]:QPCH:WALSh	517
[:FORWard]:QPCH[:STATe]	517
[:FORWard]:SRATe	517
:PNOFFset	518
:REVerse:BBCLock	518
:REVerse:CHIPrate	519
:REVerse:ESDelay	519
:REVerse:FILTer	520
:REVerse:FILTer:ALPHa	521
:REVerse:FILTer:BBT	521
:REVerse:FILTer:CHANnel	522
:REVerse:LCMask	522
:REVerse:LCSTate	522
:REVerse:PADJust	523
:REVerse:POLarity[:ALL]	523
:REVerse:NOISe:CN	523
:REVerse:NOISe[:STATe]	524
:REVerse:RC12:ACCess:RACH:DATA	524
:REVerse:RC12:ACCess:RACH:DATA:FIX4	525
:REVerse:RC12:ACCess:RACH:EBNO	525
:REVerse:RC12:ACCess:RACH:FLENgth	526
:REVerse:RC12:ACCess:RACH:FOFFset	526
:REVerse:RC12:ACCess:RACH:POWer	526
:REVerse:RC12:ACCess:RACH:RCONfig	527
:REVerse:RC12:ACCess:RACH:RATE	527
:REVerse:RC12:ACCess:RACH[:STATe]	527
:REVerse:RC12:TRAFfic:RSCH:DATA	528

Contents

:REVerse:RC12:TRAFfic:RSCH:DATA:FIX4	528
:REVerse:RC12:TRAFfic:RSCH:FLENgth	528
:REVerse:RC12:TRAFfic:RSCH:FOFFset	529
:REVerse:RC12:TRAFfic:RSCH:POWer	529
:REVerse:RC12:TRAFfic:RSCH:RATE	529
:REVerse:RC12:TRAFfic:RSCH:RCONfig	530
:REVerse:RC12:TRAFfic:RSCH[:STATe]	530
:REVerse:RC34:CCONtrol:RCCCh:DATA	530
:REVerse:RC34:CCONtrol:RCCCh:DATA:FIX4	531
:REVerse:RC34:CCONtrol:RCCCh:EBNO	531
:REVerse:RC34:CCONtrol:RCCCh:FLENgth	532
:REVerse:RC34:CCONtrol:RCCCh:FOFFset	532
:REVerse:RC34:CCONtrol:RCCCh:POWer	532
:REVerse:RC34:CCONtrol:RCCCh:RCONfig	533
:REVerse:RC34:CCONtrol:RCCCh:RATE	533
:REVerse:RC34:CCONtrol:RCCCh:WALSh	533
:REVerse:RC34:CCONtrol:RCCCh[:STATe]	534
:REVerse:RC34:CCONtrol:RPICH:ECNO	534
:REVerse:RC34:CCONtrol:RPICH:GRATe	535
:REVerse:RC34:CCONtrol:RPICH:POWer	535
:REVerse:RC34:CCONtrol:RPICH:WALSh	535
:REVerse:RC34:CCONtrol:RPICH[:STATe]	536
:REVerse:RC34:EACCess:REACH:DATA	536
:REVerse:RC34:EACCess:REACH:DATA:FIX4	536
:REVerse:RC34:EACCess:REACH:EBNO	537
:REVerse:RC34:EACCess:REACH:FOFFset	537
:REVerse:RC34:EACCess:REACH:POWer	538
:REVerse:RC34:EACCess:REACH:RCONfig	538
:REVerse:RC34:EACCess:REACH:RATE	538
:REVerse:RC34:EACCess:REACH:WALSh	539
:REVerse:RC34:EACCess:REACH[:STATe]	539
:REVerse:RC34:EACCess:RPICH:ECNO	539
:REVerse:RC34:EACCess:RPICH:GRATe	540
:REVerse:RC34:EACCess:RPICH:POWer	540
:REVerse:RC34:EACCess:RPICH:WALSh	540
:REVerse:RC34:EACCess:RPICH[:STATe]	541
:REVerse:RC34:TRAFfic:RDCCh:DATA	541
:REVerse:RC34:TRAFfic:RDCCh:DATA:FIX4	541

:REVerse:RC34:TRAFfic:RDCCh:EBNO	.542
:REVerse:RC34:TRAFfic:RDCCh:FLENgth	.542
:REVerse:RC34:TRAFfic:RDCCh:FOFFset.	.542
:REVerse:RC34:TRAFfic:RDCCh:POWer.	.543
:REVerse:RC34:TRAFfic:RDCCh:RATE.	.543
:REVerse:RC34:TRAFfic:RDDCh:RCONfig.	.543
:REVerse:RC34:TRAFfic:RDCCh:WALSh	.544
:REVerse:RC34:TRAFfic:RDCCh[:STATe]	.544
:REVerse:RC34:TRAFfic:RFCH:DATA.	.544
:REVerse:RC34:TRAFfic:RFCH:DATA:FIX4	.545
:REVerse:RC34:TRAFfic:RFCH:EBNO	.545
:REVerse:RC34:TRAFfic:RFCH:FLENgth	.546
:REVerse:RC34:TRAFfic:RFCH:FOFFset	.546
:REVerse:RC34:TRAFfic:RFCH:POWer	.546
:REVerse:RC34:TRAFfic:RFCH:RCONfig	.547
:REVerse:RC34:TRAFfic:RFCH:RATE	.547
:REVerse:RC34:TRAFfic:RFCH:WALSh	.547
:REVerse:RC34:TRAFfic:RFCH[:STATe]	.547
:REVerse:RC34:TRAFfic:RSCH[1]2:DATA	.548
:REVerse:RC34:TRAFfic:RSCH[1]2:DATA:FIX4	.548
:REVerse:RC34:TRAFfic:RSCH[1]2:DATA:EBNO	.548
:REVerse:RC34:TRAFfic:RSCH[1]2:FLENgth.	.549
:REVerse:RC34:TRAFfic:RSCH[1]2:FOFFset	.549
:REVerse:RC34:TRAFfic:RSCH[1]2:POWer	.550
:REVerse:RC34:TRAFfic:RSCH[1]2:RCONfig	.550
:REVerse:RC34:TRAFfic:RSCH[1]2:RATE	.550
:REVerse:RC34:TRAFfic:RSCH[1]2:TCODE.	.551
:REVerse:RC34:TRAFfic:RSCH[1]2:WALSh.	.551
:REVerse:RC34:TRAFfic:RSCH[1]2[:STATe]	.551
:REVerse:REFeRence:EXTeRnal:FREQUency	.552
:REVerse:REFeRence[:SOURce].	.552
:REVerse:TADVance.	.552
:REVerse:TEDGE	.553
:REVerse:SRATE	.553
[:STATe]	.553
Custom Subsystem–Option 001/601or 002/602 ([:SOURce]:RADio:CUSTom).	.554
:ALPha	.554
:ASK	.554

Contents

:BBCLock	555
:BBT	555
:BRATe	556
:BURSt:SHAPe:FALL:DELay	558
:BURSt:SHAPe:FALL:TIME	558
:BURSt:SHAPe:FDELay	559
:BURSt:SHAPe:FTIME	559
:BURSt:SHAPe:RDELay	560
:BURSt:SHAPe:RISE:DELay	560
:BURSt:SHAPe:RISE:TIME	561
:BURSt:SHAPe:RTIME	562
:BURSt:SHAPe[:TYPE]	562
:CHANnel	563
:DATA	563
:DATA:FIX4	564
:DATA:PRAM	564
:DENCode	565
:EDATa:DELay	565
:EDCLock	565
:EREference	566
:EREference:VALue	566
:FILTer	567
:IQ:SCALE	568
:MODulation:FSK[:DEVIation]	569
:MODulation:MSK[:PHASe]	569
:MODulation:UFSK	570
:MODulation:UIQ	570
:MODulation[:TYPE]	570
:POLarity[:ALL]	571
:SRATe	571
:STANdard:SELect	573
:TRIGger:TYPE	573
:TRIGger:TYPE:CONTInuous[:TYPE]	574
:TRIGger:TYPE:GATE:ACTive	574
:TRIGger[:SOURce]	576
:TRIGger[:SOURce]:EXTernal:DELay	577
:TRIGger[:SOURce]:EXTernal:DELay:STATe	577
:TRIGger[:SOURce]:EXTernal:SLOPe	578

:TRIGger[:SOURce]:EXTernal[:SOURce].	578
[:STATe]	579
DECT Subsystem–Option 402 ([:SOURce]:RADio:DECT)	580
:ALPha	580
:BBCLock	580
:BBT	581
:BRATe	581
:BURSt:PN9	582
:BURSt:SHAPe:FALL:DELay	583
:BURSt:SHAPe:FALL:TIME	583
:BURSt:SHAPe:FDELay	584
:BURSt:SHAPe:FTIME.	584
:BURSt:SHAPe:RDELay	585
:BURSt:SHAPe:RISE:DELay.	585
:BURSt:SHAPe:RISE:TIME	586
:BURSt:SHAPe:RTIME.	587
:BURSt:SHAPe[:TYPE]	587
:BURSt[:STATe]	588
:CHANnel	588
:DATA	589
:DATA:FIX4	589
:DATA:PRAM.	590
:DEFault	590
:EDATa:DELay	590
:EDCLock	591
:EREFerence	591
:EREFerence:VALue.	592
:FILTer.	592
:IQ:SCALE	593
:MODulation:FSK[:DEViation]	593
:MODulation:MSK[:PHASe]	594
:MODulation:UFSK	594
:MODulation:UIQ	595
:MODulation[:TYPE]	595
:POLarity[:ALL]	595
:PPart:SLOT0 [1] 2 3 4 5 6 7 8 9 10 11[:TYPE].	596
:PPart:SLOT0 [1] 2 3 4 5 6 7 8 9 10 11:CUSTom.	596
:PPart:SLOT0 [1] 2 3 4 5 6 7 8 9 10 11:CUSTom:FIX4.	597

Contents

:PPart:SLOT0[1]2 3 4 5 6 7 8 9 10 11:LCAPacity:A	597
:PPart:SLOT0[1]2 3 4 5 6 7 8 9 10 11:LCAPacity:P	598
:PPart:SLOT0[1]2 3 4 5 6 7 8 9 10 11:LCAPacity:S	598
:PPart:SLOT0[1]2 3 4 5 6 7 8 9 10 11:LCAPacity[:B]	599
:PPart:SLOT0[1]2 3 4 5 6 7 8 9 10 11:LCAPacity[:B]:FIX4	599
:PPart:SLOT0[1]2 3 4 5 6 7 8 9 10 11:LCAPacity:POWer	600
:PPart:SLOT0[1]2 3 4 5 6 7 8 9 10 11:STATe	600
:PPart:SLOT0[1]2 3 4 5 6 7 8 9 10 11:TRAFfic:A	600
:PPart:SLOT0[1]2 3 4 5 6 7 8 9 10 11:TRAFfic:P	601
:PPart:SLOT0[1]2 3 4 5 6 7 8 9 10 11:TRAFfic:S	601
:PPart:SLOT0[1]2 3 4 5 6 7 8 9 10 11:TRAFfic[:B]	602
:PPart:SLOT0[1]2 3 4 5 6 7 8 9 10 11:TRAFfic[:B]:FIX4	602
:PPart:SLOT0[1]2 3 4 5 6 7 8 9 10 11:ZLCapacity:A	603
:PPart:SLOT0[1]2 3 4 5 6 7 8 9 10 11:ZLCapacity:P	603
:PPart:SLOT0[1]2 3 4 5 6 7 8 9 10 11:ZLCapacity:A	603
:PPart:SLOT0[1]2 3 4 5 6 7 8 9 10 11:ZLCapacity[:B]	604
:PPart:SLOT0[1]2 3 4 5 6 7 8 9 10 11:ZLCapacity[:B]:FIX4	604
:PPart:SLOT0[1]2 3 4 5 6 7 8 9 10 11:ZTRaffic:A	605
:PPart:SLOT0[1]2 3 4 5 6 7 8 9 10 11:ZTRaffic:P	605
:PPart:SLOT0[1]2 3 4 5 6 7 8 9 10 11:ZTRaffic:S	605
:PPart:SLOT0[1]2 3 4 5 6 7 8 9 10 11:ZTRaffic[:B]	606
:PPart:SLOT0[1]2 3 4 5 6 7 8 9 10 11:ZTRaffic[:B]:FIX4	606
:RFPart:SLOT0[1]2 3 4 5 6 7 8 9 10 11[:TYPE]	607
:RFPart:SLOT0[1]2 3 4 5 6 7 8 9 10 11:CUSTOm	607
:RFPart:SLOT0[1]2 3 4 5 6 7 8 9 10 11:CUSTOm:FIX4	608
:RFPart:SLOT0[1]2 3 4 5 6 7 8 9 10 11:DUMM2:A	608
:RFPart:SLOT0[1]2 3 4 5 6 7 8 9 10 11:DUMM2:P	609
:RFPart:SLOT0[1]2 3 4 5 6 7 8 9 10 11:DUMM2:S	609
:RFPart:SLOT0[1]2 3 4 5 6 7 8 9 10 11:DUMM[1]:A	609
:RFPart:SLOT0[1]2 3 4 5 6 7 8 9 10 11:DUMM[1]:P	610
:RFPart:SLOT0[1]2 3 4 5 6 7 8 9 10 11:DUMM[1]:S	610
:RFPart:SLOT0[1]2 3 4 5 6 7 8 9 10 11:LCAPacity:A	610
:RFPart:SLOT0[1]2 3 4 5 6 7 8 9 10 11:LCAPacity:P	611
:RFPart:SLOT0[1]2 3 4 5 6 7 8 9 10 11:LCAPacity:S	611
:RFPart:SLOT0[1]2 3 4 5 6 7 8 9 10 11:LCAPacity[:B]	611
:RFPart:SLOT0[1]2 3 4 5 6 7 8 9 10 11:LCAPacity[:B]:FIX4	612
:RFPart:SLOT0[1]2 3 4 5 6 7 8 9 10 11:LCAPacity:POWer	612
:RFPart:SLOT0[1]2 3 4 5 6 7 8 9 10 11:STATe	613

:RFPart:SLOT0[1] 2 3 4 5 6 7 8 9 10 11:TRAFfic:A	.613
:RFPart:SLOT0[1] 2 3 4 5 6 7 8 9 10 11:TRAFfic:P	.613
:RFPart:SLOT0[1] 2 3 4 5 6 7 8 9 10 11:TRAFfic:S	.614
:RFPart:SLOT0[1] 2 3 4 5 6 7 8 9 10 11:TRAFfic[:B]	.614
:RFPart:SLOT0[1] 2 3 4 5 6 7 8 9 10 11:TRAFfic[:B]:FIX4	.615
:RFPart:SLOT0[1] 2 3 4 5 6 7 8 9 10 11:ZLCapacity:A	.615
:RFPart:SLOT0[1] 2 3 4 5 6 7 8 9 10 11:ZLCapacity:P	.615
:RFPart:SLOT0[1] 2 3 4 5 6 7 8 9 10 11:ZLCapacity:S	.616
:RFPart:SLOT0[1] 2 3 4 5 6 7 8 9 10 11:ZLCapacity[:B]	.616
:RFPart:SLOT0[1] 2 3 4 5 6 7 8 9 10 11:ZLCapacity[:B]:FIX4	.617
:RFPart:SLOT0[1] 2 3 4 5 6 7 8 9 10 11:ZTRaffic:A	.617
:RFPart:SLOT0[1] 2 3 4 5 6 7 8 9 10 11:ZTRaffic:P	.617
:RFPart:SLOT0[1] 2 3 4 5 6 7 8 9 10 11:ZTRaffic:S	.618
:RFPart:SLOT0[1] 2 3 4 5 6 7 8 9 10 11:ZTRaffic[:B]	.618
:RFPart:SLOT0[1] 2 3 4 5 6 7 8 9 10 11:ZTRaffic[:B]:FIX4	.619
:SECondary:RECall	.619
:SECondary:SAVE	.619
:SECondary:TRIGger[:SOURce]	.620
:SECondary[:STATe].	.620
:SOUT	.621
:SOUT:OFFSet	.621
:SOUT:SLOT	.622
:SRATe	.622
:TRIGger:TYPE	.623
:TRIGger:TYPE:CONTInuous[:TYPE]	.624
:TRIGger:TYPE:GATE:ACTive	.625
:TRIGger[:SOURce]	.625
:TRIGger[:SOURce]:EXTernal:DELay	.626
:TRIGger[:SOURce]:EXTernal:SLOPe	.627
:TRIGger[:SOURce]:EXTernal[:SOURce].	.627
:TRIGger[:SOURce]:EXTernal:DELay:STATe	.628
[:STATe]	.628
EDGE Subsystem–Option 402 ([:SOURce]:RADio:EDGE)	.629
:ALPHa	.629
:BBCLock	.629
:BBT	.630
:BURSt:SHAPe:FALL:DELay	.630
:BURSt:SHAPe:FDELay	.631

Contents

:BURSt:SHAPe:FALL:TIME	632
:BURSt:SHAPe:FTIME	632
:BURSt:SHAPe:RDELAy	633
:BURSt:SHAPe:RISE:DELAy	634
:BURSt:SHAPe:RISE:TIME	634
:BURSt:SHAPe:RTIME	635
:BURSt:SHAPe[:TYPE].	636
:BURSt[:STATe].	636
:CHANnel	637
:DATA	637
:DATA:PRAM.	638
:DATA:FIX4	638
:DEFAult	639
:EDATa:DELAy	639
:EDCLock	639
:EREFeRence	640
:EREFeRence:VALue.	640
:FILTer	641
:IQ:SCALE	642
:MODulation:FSK[:DEVIation]	642
:MODulation:MSK[:PHASe]	643
:MODulation:UFSK	643
:MODulation:UIQ.	643
:MODulation[:TYPE].	644
:POLarity[:ALL].	644
:SECondary:RECall	645
:SECondary:SAVE	645
:SECondary:TRIGger[:SOURce]	645
:SECondary[:STATe]	646
:SLOT0 [1] 2 3 4 5 6 7:CUSTom.	646
:SLOT0 [1] 2 3 4 5 6 7:CUSTom:FIX4	647
:SLOT0 [1] 2 3 4 5 6 7:CUSTom:GUARd	647
:SLOT0 [1] 2 3 4 5 6 7:GMSK:ENCRyption.	648
:SLOT0 [1] 2 3 4 5 6 7:GMSK:ENCRyption:CS1:DATA	649
:SLOT0 [1] 2 3 4 5 6 7:GMSK:ENCRyption:CS4:DATA	650
:SLOT0 [1] 2 3 4 5 6 7:GMSK:ENCRyption:DLINK:MCS1:DATA.	650
:SLOT0 [1] 2 3 4 5 6 7:GMSK:ENCRyption:FIX4	650
:SLOT0 [1] 2 3 4 5 6 7:GMSK:ENCRyption:TCH:FS:DATA	651

:SLOT0[1]2 3 4 5 6 7:GMSK:ENCryption:ULINK:MCS1:DATA	.651
:SLOT0[1]2 3 4 5 6 7:GMSK:STeal	.652
:SLOT0[1]2 3 4 5 6 7:GMSK:TSEquence	.652
:SLOT0[1]2 3 4 5 6 7:MULTislot	.653
:SLOT0[1]2 3 4 5 6 7:NORMAl:ENCryption	.653
:SLOT0:NORMAl:ENCryption:BCH:BCC	.655
:SLOT0:NORMAl:ENCryption:BCH:CELLid	.656
:SLOT0:NORMAl:ENCryption:BCH:LAC	.656
:SLOT0:NORMAl:ENCryption:BCH:MCC	.656
:SLOT0:NORMAl:ENCryption:BCH:MNC	.657
:SLOT0:NORMAl:ENCryption:BCH:PLMN	.657
:SLOT0[1]2 3 4 5 6 7:NORMAl:ENCryption:DLINK:MCS5:DATA	.657
:SLOT0[1]2 3 4 5 6 7:NORMAl:ENCryption:DLINK:MCS9:DATA	.658
:SLOT0[1]2 3 4 5 6 7:NORMAl:ENCryption:ETCH:F43:DATA	.658
:SLOT0[1]2 3 4 5 6 7:NORMAl:ENCryption:FIX4	.659
:SLOT0[1]2 3 4 5 6 7:NORMAl:ENCryption:ULINK:MCS5:DATA	.659
:SLOT0[1]2 3 4 5 6 7:NORMAl:ENCryption:ULINK:MCS9:DATA	.660
:SLOT0[1]2 3 4 5 6 7:NORMAl:ENCryption:UNCoded	.660
:SLOT0[1]2 3 4 5 6 7:NORMAl:GUARd	.661
:SLOT0[1]2 3 4 5 6 7:NORMAl:T1	.661
:SLOT0[1]2 3 4 5 6 7:NORMAl:T2	.662
:SLOT0[1]2 3 4 5 6 7:NORMAl:TSEquence	.662
:SLOT0[1]2 3 4 5 6 7:LCAPacity:POWer	.662
:SLOT0[1]2 3 4 5 6 7:STATe	.663
:SLOT0[1]2 3 4 5 6 7[:TYPE]	.663
:SOUT:	.664
:SOUT:OFFSet	.664
:SOUT:SLOT	.665
:SRATe	.665
:TRIGger:TYPE	.667
:TRIGger:TYPE:CONTInuous[:TYPE]	.667
:TRIGger:TYPE:GATE:ACTive	.668
:TRIGger[:SOURce]	.669
:TRIGger[:SOURce]:EXTernal:DELay	.670
:TRIGger[:SOURce]:EXTernal:DELay:FINE	.670
:TRIGger[:SOURce]:EXTernal:DELay:STATe	.671
:TRIGger[:SOURce]:EXTernal:SLOPe	.671
:TRIGger[:SOURce]:EXTernal[:SOURce]	.672

Contents

[:STATE]	672
9. Receiver Test Digital Commands (continued)	673
3GPP W-CDMA HSPA Subsystem–Option 419 ([:SOURCE]:RADio:WCDMa:HSPA[:BBG])	674
File Overview	674
Managing ESG Setting Conflicts and Error Messages	676
:DLINK:APPLY	677
:DLINK:AWGN:CN	677
:DLINK:AWGN[:STATE]	678
:DLINK:BBClock[:SOURCE]	678
:DLINK:CPICH:CCODE	678
:DLINK:CPICH:POWer	679
:DLINK:CPICH[:STATE]	679
:DLINK:DPCH:CCODE	679
:DLINK:DPCH:DATA	680
:DLINK:DPCH:DATA:FIX4	680
:DLINK:DPCH:DCH[1] 2 3 4 5 6:BSIZE	681
:DLINK:DPCH:DCH[1] 2 3 4 5 6:CRC	681
:DLINK:DPCH:DCH[1] 2 3 4 5 6:CTYPE	682
:DLINK:DPCH:DCH[1] 2 3 4 5 6:DATA	682
:DLINK:DPCH:DCH[1] 2 3 4 5 6:DATA:FIX4	683
:DLINK:DPCH:DCH[1] 2 3 4 5 6:NBLocks	683
:DLINK:DPCH:DCH[1] 2 3 4 5 6:RMATtribute	684
:DLINK:DPCH:DCH[1] 2 3 4 5 6:TTI	684
:DLINK:DPCH:DCH[1] 2 3 4 5 6[:STATE]	684
:DLINK:DPCH:POWer	685
:DLINK:DPCH:SFORmat	685
:DLINK:DPCH:SSCoffset	686
:DLINK:DPCH:TFCI	686
:DLINK:DPCH:TOFFset	687
:DLINK:DPCH:TPC:NSTeps	687
:DLINK:DPCH:TPC:PATtern	687
:DLINK:DPCH:TRPosition	688
:DLINK:DPCH[:STATE]	688
:DLINK:EAGCh:AGSCOpe	689
:DLINK:EAGCh:AGValue	689
:DLINK:EAGCh:CCODE	690
:DLINK:EAGCh:ERNTI	691

:DLINK:EAGCh:Power	.691
:DLINK:EAGCh[:STATe]	.691
:DLINK:EHICH:CCODE	.692
:DLINK:EHICH:INDicator	.692
:DLINK:EHICH:POWer	.693
:DLINK:EHICH:SSINdex	.693
:DLINK:EHICH:TOFFset	.693
:DLINK:EHICH[:STATe]	.694
:DLINK:ERGCh:CCODE	.694
:DLINK:ERGCh:POWer	.694
:DLINK:ERGCh:RGValue	.695
:DLINK:ERGCh:SSINdex	.695
:DLINK:ERGCh:TOFFset	.696
:DLINK:ERGCh[:STATe]	.696
:DLINK:FILTer	.696
:DLINK:FILTer:ALPHa	.697
:DLINK:FILTer:BBT	.698
:DLINK:FILTer:CHANnel	.698
:DLINK:HSBurst	.698
:DLINK:HSDPa:AMC:CQIMapping:UECategory	.699
:DLINK:HSDPa:AMC:CPATtern	.699
:DLINK:HSDPa:FCONtrol	.700
:DLINK:HSDPa:HARQ:APATtern	.701
:DLINK:HSDPa:HARQ:MNHTrans	.702
:DLINK:HSDPa:HARQ:RVSequence[1] 2 3 4 5 6 7 8	.702
:DLINK:HSDPa[1] 2 3 4:BSINfo	.703
:DLINK:HSDPa[1] 2 3 4:HSPDSch:COFFset	.703
:DLINK:HSDPa[1] 2 3 4:HSPDSch:DATA	.704
:DLINK:HSDPa[1] 2 3 4:HSPDSch:DATA:FIX4	.704
:DLINK:HSDPa:HSPDSch:DSCH:DATA	.705
:DLINK:HSDPa:HSPDSch:DSCH:DATA:FIX4	.705
:DLINK:HSDPa:HSPDSch:DSCH:IRBSize	.706
:DLINK:HSDPa:HSPDSch:NCODE	.706
:DLINK:HSDPa[1] 2 3 4:HSPDSch:POWer	.706
:DLINK:HSDPa[1] 2 3 4:HSPDSch:SFORmat	.707
:DLINK:HSDPa[1] 2 3 4:HSPDSch[:STATe]	.707
:DLINK:HSDPa[1] 2 3 4:HSSCch:CCODE	.708
:DLINK:HSDPa[1] 2 3 4:HSSCch:DATA	.708

Contents

:DLINK:HSDPa[1] 2 3 4:HSSCch:DATA:FIX4	709
:DLINK:HSDPa[1] 2 3 4:HSSCch:POWer	709
:DLINK:HSDPa[1] 2 3 4:ITTI	710
:DLINK:HSDPa[1] 2 3 4:ITTI:PATtern	710
:DLINK:HSDPa:NHPRocess	711
:DLINK:HSDPa[1] 2 3 4:RVParameter	711
:DLINK:HSDPa[1] 2 3 4:UEID	712
:DLINK:HSDPa[1] 2 3 4[:STATe]	712
:DLINK:OCNS[1] 2 3 4 5 6 7 8 9 10 11 12 13 14 15 16:CCODE	713
:DLINK:OCNS[1] 2 3 4 5 6 7 8 9 10 11 12 13 14 15 16:DATA	713
:DLINK:OCNS[1] 2 3 4 5 6 7 8 9 10 11 12 13 14 15 16:MODulation	714
:DLINK:OCNS[1] 2 3 4 5 6 7 8 9 10 11 12 13 14 15 16:POWer	714
:DLINK:OCNS[1] 2 3 4 5 6 7 8 9 10 11 12 13 14 15 16:SF	714
:DLINK:OCNS[1] 2 3 4 5 6 7 8 9 10 11 12 13 14 15 16:SSCoffset	715
:DLINK:OCNS[1] 2 3 4 5 6 7 8 9 10 11 12 13 14 15 16:TOFFset	715
:DLINK:OCNS[1] 2 3 4 5 6 7 8 9 10 11 12 13 14 15 16[:STATe]	716
:DLINK:PCCPch:BCH:DATA	716
:DLINK:PCCPch:BCH:DATA:FIX4	716
:DLINK:PCCPch:CCODE	717
:DLINK:PCCPch:POWer	717
:DLINK:PCCPch[:STATe]	718
:DLINK:PICH:CCODE	718
:DLINK:PICH:DATA	718
:DLINK:PICH:DATA:FIX4	719
:DLINK:PICH:POWer	719
:DLINK:PICH[:STATe]	720
:DLINK:POLarity	720
:DLINK:PSCH:POWer	720
:DLINK:PSCH[:STATe]	721
:DLINK:SCRamblecode	721
:DLINK:SSCH:POWer	721
:DLINK:SSCH[:STATe]	722
:DLINK:TXDiversity	722
:LINK	722
:ULINK:APPLy	723
:ULINK:AWGN:CN	723
:ULINK:AWGN[:STATe]	724
:ULINK:BBReference:EXTernal:MRATe	724

:ULINK:BBReference:EXTeRnal[:SOURce].	724
:ULINK:CRATe	725
:ULINK:DPCCh:CCODE.	725
:ULINK:DPCCh:DATA	725
:ULINK:DPCCh:DATA:FIX4	726
:ULINK:DPCCh:FBI:PATTeRn	726
:ULINK:DPCCh:FBI:PATTeRn:FIX.	726
:ULINK:DPCCh:POWeR	727
:ULINK:DPCCh:SFOrmat	727
:ULINK:DPCCh:TFCI.	728
:ULINK:DPCCh:TPC:NSTePs	728
:ULINK:DPCCh:TPC:PATTeRn	728
:ULINK:DPCCh[:STATe]	729
.	729
:ULINK:DPDCh:DATA.	730
:ULINK:DPDCh:DATA:FIX4	730
:ULINK:DPDCh:DCH[1]2 3 4 5 6:BSIZe.	731
:ULINK:DPDCh:DCH[1]2 3 4 5 6:CRC.	731
:ULINK:DPDCh:DCH[1]2 3 4 5 6:CTYPe	732
:ULINK:DPDCh:DCH[1]2 3 4 5 6:DATA.	732
:ULINK:DPDCh:DCH[1]2 3 4 5 6:DATA:FIX4	733
:ULINK:DPDCh:DCH[1]2 3 4 5 6:NBLocks	733
:ULINK:DPDCh:DCH[1]2 3 4 5 6:RMATtribute	734
:ULINK:DPDCh:DCH[1]2 3 4 5 6:TTI.	734
:ULINK:DPDCh:DCH2 3 4 5 6[:STATe]	734
:ULINK:DPDCh:POWeR	735
:ULINK:DPDCh:SFOrmat	735
:ULINK:DPDCh[:STATe]	736
:ULINK:FCLock:INTeRval	736
:ULINK:FCLock:POLarity	736
:ULINK:FILTeR	737
:ULINK:FILTeR:ALPHa.	737
:ULINK:FILTeR:BBT	738
:ULINK:FILTeR:CHANnel.	738
:ULINK:FOFFset.	739
:ULINK:HCONfig	739
:ULINK:HSDPcch:APATteRn	739
:ULINK:HSDPcch:APOWeR	740

Contents

:ULINK:HSDPcch:CCODE	740
:ULINK:HSDPcch:CPATtern	741
:ULINK:HSDPcch:CPOWer	741
:ULINK:HSDPcch:NPOWer	742
:ULINK:HSDPcch:SFDelay	742
:ULINK:HSDPcch[:STATe]	742
	743
:ULINK:HSUPa:EDPCch:DATA:FIX4	743
:ULINK:HSUPa:EDPCch:POWer	743
:ULINK:HSUPa:EDPCch[:STATe]	744
:ULINK:HSUPa:EDPDch:DATA	744
:ULINK:HSUPa:EDPDch:DATA:FIX4	744
:ULINK:HSUPa:EDPDch:EDCH:DATA	745
:ULINK:HSUPa:EDPDch:EDCH:DATA:FIX4	745
:ULINK:HSUPa:EDPDch:MCCodes	746
:ULINK:HSUPa:EDPDch:PLNMax	747
:ULINK:HSUPa:EDPDch:POWer	747
:ULINK:HSUPa:EDPDch:SNPHchs	747
:ULINK:HSUPa:EDPDch[:STATe]	748
:ULINK:HSUPa:ETABLE	748
:ULINK:HSUPa:ETFCi	749
:ULINK:HSUPa:HARQ:APATtern	749
:ULINK:HSUPa:HARQ:APATtern[:EXTErnal]:DELay	750
:ULINK:HSUPa:HARQ:APATtern[:EXTErnal]:INPut	750
:ULINK:HSUPa:HARQ:APATtern[:EXTErnal]:POLarity	751
:ULINK:HSUPa:HARQ:MNRTrans	751
:ULINK:HSUPa:HARQ[:MODE]	751
:ULINK:HSUPa:HARQ:HBIT	752
:ULINK:HSUPa:HPRocess	752
:ULINK:HSUPa:RSN	753
:ULINK:HSUPa:RVINdex	753
:ULINK:HSUPa:TFC:EPATtern[:EXTErnal]:DELay	753
:ULINK:HSUPa:TFC:EPATtern[:EXTErnal]:INPut	754
:ULINK:HSUPa:TFC:EPATtern[:EXTErnal]:POLarity	754
:ULINK:HSUPa:TFC:EPATtern	755
:ULINK:HSUPa:TFC[:ALT]:EDPCch:POWer	755
:ULINK:HSUPa:TFC[:ALT]:EDPDch:EDCH:DATA	756
:ULINK:HSUPa:TFC[:ALT]:EDPDch:EDCH:DATA:FIX4	756

:ULINK:HSUPa:TFC[:ALT]:EDPDch:POWer	757
:ULINK:HSUPa:TFC[:ALT]EDPDch:SNPHchs.	757
:ULINK:HSUPa:TFC[:ALT]:ETABle	758
:ULINK:HSUPa:TFC[:ALT]:ETFCI	758
:ULINK:HSUPa:TTI	758
:ULINK:HSUPa[:STATe].	759
:ULINK:NMDPdch	759
:ULINK:POLarity	759
:ULINK:SCRamblecode	760
:ULINK:SDElay	760
:ULINK:SFNRst:POLarity	760
:ULINK:SYNC:MODE	761
:ULINK:SYNC[:SOURce]	761
:ULINK:TGAP:PSI[1]:CFN	762
:ULINK:TGAP:PSI[1]:D	762
:ULINK:TGAP:PSI[1]:L1	762
:ULINK:TGAP:PSI[1]:L2	763
:ULINK:TGAP:PSI[1]:PL1	763
:ULINK:TGAP:PSI[1]:PRC	763
:ULINK:TGAP:PSI[1]:PS	763
:ULINK:TGAP:PSI[1]:SN.	764
:ULINK:TOFFset.	764
:ULINK:TPControl:PATtern	765
:ULINK:TPControl:PATtern[:EXTernal]:INPut	765
:ULINK:TPControl:PATtern[:EXTernal]:POLarity	765
:ULINK:TPControl:POWer:INITial	766
:ULINK:TPControl:POWer:MAXimum	766
:ULINK:TPControl:POWer:MINimum	767
:ULINK:TPControl:POWer:STEP.	767
:ULINK:TPControl[:STATe]	768
[:STATe]	768
Real Time GPS Subsystem–Option 409	
([:SOURce]:RADio[1]2 3 4:GPS)	769
:DATA	769
:DMODE	769
:DSHift	770
:FILTer.	770
:FILTer:ALPHa	771
:FILTer:BBT	772

Contents

:FILTer:CHANnel	772
:IQPHase	773
:PCODE	773
:RCODE	773
:REFClk	774
:REFFreq	774
:SATid	775
[:STATe]	775
Real Time MSGPS Subsystem–Option 409 ([:SOURce]:RADio[1]2 3 4:MSGPs)	776
:IQPHase	776
:PMODE	776
:REFClk	777
:REFFreq	777
:REStart	777
:SCENario	778
:SCENario:SATellites	778
:SCENario:STATus	778
[:STATe]	778
GSM Subsystem–Option 402 ([:SOURce]:RADio:GSM)	779
:ALpha	779
:BBCLock	779
:BBT	780
:BRATe	780
:BURSt:PN9	781
:BURSt:SHAPe:FALL:DELay	782
:BURSt:SHAPe:FALL:TIME	782
:BURSt:SHAPe:FDELay	783
:BURSt:SHAPe:FTIME	784
:BURSt:SHAPe:RDELay	784
:BURSt:SHAPe:RISE:DELay	785
:BURSt:SHAPe:RISE:TIME	786
:BURSt:SHAPe:RTIME	786
:BURSt:SHAPe[:TYPE]	787
:BURSt[:STATe]	787
:CHANnel	788
:DATA	788
:DATA:PRAM	789
:DATA:FIX4	789

:DEFault	789
:DENCode	790
EDATa:DELay	790
:EDCLock	790
:EREFerence	791
:EREFerence:VALue	791
:FILTer	792
:IQ:SCALE	793
:MODulation:FSK[:DEViation]	793
:MODulation:MSK[:PHASe]	794
:MODulation:UFSK	794
:MODulation:UIQ	794
:MODulation[:TYPE]	795
:POLarity[:ALL]	795
:SECondary:RECall	796
:SECondary:SAVE	796
:SECondary:TRIGger[:SOURce]	796
:SECondary[:STATE]	797
:SLOT0[1]2 3 4 5 6 7:ACCess:ENCRyption	797
:SLOT0[1]2 3 4 5 6 7:ACCess:ENCRyption:FIX4	797
:SLOT0[1]2 3 4 5 6 7:ACCess:ETAil	798
:SLOT0[1]2 3 4 5 6 7:ACCess:SSEQuence	798
:SLOT0[1]2 3 4 5 6 7:ACCess:CUSTom	798
:SLOT0[1]2 3 4 5 6 7:CUSTom:FIX4	799
:SLOT0[1]2 3 4 5 6 7:DUMMy:TSEQuence	799
:SLOT0[1]2 3 4 5 6 7:MULTIslot	799
SLOT0[1]2 3 4 5 6 7:NORMal:ENCRyption	800
:SLOT0:NORMal:ENCRyption:BCH1:BCC	802
:SLOT0:NORMal:ENCRyption:BCH1:CELLid	802
:SLOT0:NORMal:ENCRyption:BCH1:LAC	802
:SLOT0:NORMal:ENCRyption:BCH1:MCC	803
:SLOT0:NORMal:ENCRyption:BCH1:MNC	803
:SLOT0:NORMal:ENCRyption:BCH1:PLMN	803
:SLOT0[1]2 3 4 5 6 7:NORMal:ENCRyption:CS1:DATA	804
:SLOT0[1]2 3 4 5 6 7:NORMal:ENCRyption:CS4:DATA	804
:SLOT0[1]2 3 4 5 6 7:NORMal:ENCRyption:DLINK:MCS1:DATA	804
:SLOT0[1]2 3 4 5 6 7:NORMal:ENCRyption:FIX4	805
:SLOT0[1]2 3 4 5 6 7:NORMal:ENCRyption:TCH:FS:DATA	805

Contents

:SLOT0[1]2 3 4 5 6 7:NORMAl:ENCRyption:ULINK:MCS1:DATA	805
:SLOT0[1]2 3 4 5 6 7:NORMAl:STeal	806
:SLOT0[1]2 3 4 5 6 7:NORMAl:TSEquence.	806
:SLOT0[1]2 3 4 5 6 7:POWer	807
:SLOT0[1]2 3 4 5 6 7:STATe	807
:SLOT0[1]2 3 4 5 6 7:SYNC:ENCRyption	807
:SLOT0[1]2 3 4 5 6 7:SYNC:ENCRyption:FIX4	808
:SLOT0[1]2 3 4 5 6 7:SYNC:TSEquence.	808
:SLOT0[1]2 3 4 5 6 7[:TYPE]	808
:SOUT.	809
:SOUT:OFFSet	809
:SOUT:SLOT	810
:SRATe	810
:TRIGger:EXTernal:DELay	8 1 1
:TRIGger:TYPE	812
:TRIGger:TYPE:CONTInuous[:TYPE]	812
:TRIGger:TYPE:GATE:ACTive.	813
:TRIGger[:SOURce].	813
:TRIGger[:SOURce]:EXTernal:DELay	814
:TRIGger[:SOURce]:EXTernal:DELay:FINe	815
:TRIGger[:SOURce]:EXTernal:DELay:STATe	815
:TRIGger[:SOURce]:EXTernal:SLOPe	815
:TRIGger[:SOURce]:EXTernal[:SOURce]	816
[:STATe]	817
HSDPA over W-CDMA Subsystem–Option 418 ([:SOURce]:RADio:WCDMa:HSDPa[:BBG])	818
File Overview	818
Managing ESG Setting Conflicts and Error Messages.	820
:DLINK:APPLy	820
:DLINK:AWGN:CN	821
:DLINK:AWGN[:STATe]	8 2 1
:DLINK:BBCLock[:SOURce]	821
:DLINK:CPICH:CCODE	822
:DLINK:CPICH:POWer.	822
:DLINK:CPICH[:STATe]	822
:DLINK:DPCH:CCODE	8 2 2
:DLINK:DPCH:DATA.	823
:DLINK:DPCH:DATA:FIX4	823
:DLINK:DPCH:DCH[1]2 3 4 5 6:BSIZe	824

:DLINK:DPCH:DCH[1] 2 3 4 5 6:CTYPe	824
:DLINK:DPCH:DCH[1] 2 3 4 5 6:CRC	825
:DLINK:DPCH:DCH[1] 2 3 4 5 6:DATA	825
:DLINK:DPCH:DCH[1] 2 3 4 5 6:DATA:FIX4	825
:DLINK:DPCH:DCH[1] 2 3 4 5 6:NBLocks	826
:DLINK:DPCH:DCH[1] 2 3 4 5 6:RMATtribute	826
:DLINK:DPCH:DCH[1] 2 3 4 5 6:TTI	827
:DLINK:DPCH:DCH2 3 4 5 6[:STATe]	827
:DLINK:DPCH:POWer	827
:DLINK:DPCH:SFORmat	828
:DLINK:DPCH:SSCOffset	828
:DLINK:DPCH:TFCI	829
:DLINK:DPCH:TOFFset	829
:DLINK:DPCH:TPC:NSTeps	830
:DLINK:DPCH:TPC:PATTern	830
:DLINK:DPCH:TRPosition	831
:DLINK:DPCH[:STATe]	831
:DLINK:FILTer	831
:DLINK:FILTer:ALPHa	832
:DLINK:FILTer:BBT	832
:DLINK:FILTer:CHANnel	833
:DLINK:HSBurst	833
:DLINK:HSDPa:AMC:CQIMapping:UECategory	834
:DLINK:HSDPa:AMC:CPATtern	834
:DLINK:HSDPa:FCONtrol	835
:DLINK:HSDPa:HARQ:APATtern	836
:DLINK:HSDPa:HARQ:MNHTrans	836
:DLINK:HSDPa:HARQ:RVSequence[1] 2 3 4 5 6 7 8	837
:DLINK:HSDPa[1] 2 3 4:BSINfo	838
:DLINK:HSDPa[1] 2 3 4:HSPDSch:COFFset	838
:DLINK:HSDPa[1] 2 3 4:HSPDSch:DATA	838
:DLINK:HSDPa[1] 2 3 4:HSPDSch:DATA:FIX4	839
:DLINK:HSDPa:HSPDSch:DSCH:DATA	839
:DLINK:HSDPa:HSPDSch:DSCH:DATA:FIX4	840
:DLINK:HSDPa:HSPDSch:DSCH:IRBSize	840
:DLINK:HSDPa:HSPDSch:NCODe	841
:DLINK:HSDPa[1] 2 3 4:HSPDSch:POWer	841
:DLINK:HSDPa[1] 2 3 4:HSPDSch:SFORmat	842

Contents

:DLINK:HSDPa[1] 2 3 4:HSPDsch[:STATe]	842
:DLINK:HSDPa[1] 2 3 4:HSSCch:CCODE	843
:DLINK:HSDPa[1] 2 3 4:HSSCch:DATA	843
:DLINK:HSDPa[1] 2 3 4:HSSCch:DATA:FIX4	844
:DLINK:HSDPa[1] 2 3 4:HSSCch:POWer	844
:DLINK:HSDPa[1] 2 3 4:ITTI	845
:DLINK:HSDPa[1] 2 3 4:ITTI:PATtern	845
:DLINK:HSDPa:NHPRocess	846
:DLINK:HSDPa[1] 2 3 4:RVParameter	846
:DLINK:HSDPa[1] 2 3 4:UEID	847
:DLINK:HSDPa[1] 2 3 4[:STATe]	847
:DLINK:OCNS[1] 2 3 4 5 6 7 8 9 10 11 12 13 14 15 16:CCODE	848
:DLINK:OCNS[1] 2 3 4 5 6 7 8 9 10 11 12 13 14 15 16:DATA	848
:DLINK:OCNS[1] 2 3 4 5 6 7 8 9 10 11 12 13 14 15 16:POWer	849
:DLINK:OCNS[1] 2 3 4 5 6 7 8 9 10 11 12 13 14 15 16:SSCOffset	849
:DLINK:OCNS[1] 2 3 4 5 6 7 8 9 10 11 12 13 14 15 16:TOFFset	850
:DLINK:OCNS[1] 2 3 4 5 6 7 8 9 10 11 12 13 14 15 16[:STATe]	850
:DLINK:PCCPch:BCH:DATA	850
:DLINK:PCCPch:BCH:DATA:FIX4	851
:DLINK:PCCPch:CCODE	851
:DLINK:PCCPch:POWer	852
:DLINK:PCCPch[:STATe]	852
:DLINK:PICH:CCODE	852
:DLINK:PICH:DATA	853
:DLINK:PICH:DATA:FIX4	853
:DLINK:PICH:POWer	854
:DLINK:PICH[:STATe]	854
:DLINK:POLarity	854
:DLINK:PSCH:POWer	855
:DLINK:PSCH[:STATe]	855
:DLINK:SCRamblecode	855
:DLINK:SSCH:POWer	856
:DLINK:SSCH[:STATe]	856
:DLINK:TXDiversity	856
:LINK	857
:ULINK:APPLY	857
:ULINK:AWGN:CN	857
:ULINK:AWGN[:STATe]	858

:ULINK:BBReference:EXTeRnal:MRATe	.858
:ULINK:BBReference[:SOURce]	.858
:ULINK:DPCCh:CCODE	.859
:ULINK:DPCCh:DATA	.859
:ULINK:DPCCh:DATA:FIX4	.860
:ULINK:DPCCh:FBI:PATTeRn	.860
:ULINK:DPCCh:FBI:PATTeRn:FIX	.861
:ULINK:DPCCh:POWeR	.861
:ULINK:DPCCh:SFOrmat	.862
:ULINK:DPCCh[:STATe]	.862
:ULINK:DPCCh:TFCI	.862
:ULINK:DPCCh:TPC:NSTeps	.863
:ULINK:DPCCh:TPC:PATTeRn	.863
:ULINK:DPDCh:CCODE	.864
:ULINK:DPDCh:DATA	.864
:ULINK:DPDCh:DATA:FIX4	.864
:ULINK:DPDCh:DCH[1]2 3 4 5 6:BSIZe	.865
:ULINK:DPDCh:DCH[1]2 3 4 5 6:CRc	.865
:ULINK:DPDCh:DCH[1]2 3 4 5 6:CTYPe	.865
:ULINK:DPDCh:DCH[1]2 3 4 5 6:DATA	.866
:ULINK:DPDCh:DCH[1]2 3 4 5 6:DATA:FIX4	.866
:ULINK:DPDCh:DCH[1]2 3 4 5 6:NBLoCks	.867
:ULINK:DPDCh:DCH[1]2 3 4 5 6:RMATtribute	.867
:ULINK:DPDCh:DCH[1]2 3 4 5 6:TTI	.868
:ULINK:DPDCh:DCH2 3 4 5 6[:STATe]	.868
:ULINK:DPDCh:POWeR	.869
:ULINK:DPDCh:SFOrmat	.869
:ULINK:DPDCh[:STATe]	.869
:ULINK:FCLock:INTeRval	.870
:ULINK:FCLock:POLarity	.870
:ULINK:FILTeR	.871
:ULINK:FILTeR:ALPHa	.871
:ULINK:FILTeR:BBT	.872
:ULINK:FILTeR:CHANnel	.872
:ULINK:FOFFset	.873
:ULINK:HSDPcch:APATteRn	.873
:ULINK:HSDPcch:APOWeR	.874
:ULINK:HSDPcch:CCODE	.874

Contents

:ULINK:HSDPcch:CPATtern	874
:ULINK:HSDPcch:CPOWer	875
:ULINK:HSDPcch:NPOWer	875
:ULINK:HSDPcch:SFDelay	875
:ULINK:HSDPcch[:STATE]	876
:ULINK:POLarity	876
:ULINK:SCRamblecode	876
:ULINK:SDElay	877
:ULINK:SFNRst:POLarity	877
:ULINK:SYNC:MODE	878
:ULINK:SYNC[:SOURce]	878
:ULINK:TOFFset	878
[:STATE]	879
NADC Subsystem–Option 402 ([:SOURce]:RADio[:NADC])	880
:ALPha	880
:BBCLock	880
:BBT	881
:BRATe	881
:BURSt:PN9	882
:BURSt:SHAPe[:TYPE]	883
:BURSt:SHAPe:FALL:DElay	883
:BURSt:SHAPe:FALL:TIME	884
:BURSt:SHAPe:FDElay	884
:BURSt:SHAPe:FTIME	885
:BURSt:SHAPe:RDElay	886
:BURSt:SHAPe:RISE:DElay	886
:BURSt:SHAPe:RISE:TIME	887
:BURSt:SHAPe:RTIME	888
:BURSt[:STATE]	888
:BURSt:SHAPe[:TYPE]	889
:CHANnel	889
:DATA	890
:DATA:PRAM	890
:DATA:FIX4	891
:DEFault	891
:EDATa:DElay	891
:EDCLock	892
:EREFerence	892

:EREFerence:VALue893
:FILTer893
:FRATe894
:IQ:SCALE894
:MODulation:FSK[:DEViation]895
:MODulation:MSK[:PHASe]895
:MODulation:UFSK895
:MODulation:UIQ896
:MODulation[:TYPE]896
:REPeat897
:POLarity[:ALL]897
:SECondary:RECall897
:SECondary:SAVE898
:SECondary:TRIGger[:SOURce]898
:SECondary[:STATE]898
:SLOT[1] 2 3 4 5 6:DCUStom899
:SLOT[1] 2 3 4 5 6:DCUStom:FIX4899
:SLOT[1] 2 3 4 5 6:DTCHannel:CDLocator900
:SLOT[1] 2 3 4 5 6:DTCHannel:CDVCcode900
:SLOT[1] 2 3 4 5 6:DTCHannel:SACChannel900
:SLOT[1] 2 3 4 5 6:DTCHannel:SWORd901
:SLOT[1] 2 3 4 5 6:DTCHannel[:DATA]901
:SLOT[1] 2 3 4 5 6:DTCHannel[:DATA]FIX4902
:SLOT[1] 2 3 4 5 6:POWer902
:SLOT[1] 2 3 4 5 6:STATe902
:SLOT[1] 2 3 4 5 6:UCUStom903
:SLOT[1] 2 3 4 5 6:UCUStom:FIX4903
:SLOT[1] 2 3 4 5 6:UTCHannel:CDVCcode903
:SLOT[1] 2 3 4 5 6:UTCHannel:SACChannel904
:SLOT[1] 2 3 4 5 6:UTCHannel:SWORd904
:SLOT[1] 2 3 4 5 6:UTCHannel[:DATA]904
:SLOT[1] 2 3 4 5 6:UTCHannel[:DATA]:FIX4905
:SLOT[1] 2 3 4 5 6[:TYPE]905
:SOUT906
:SOUT:OFFSet906
:SOUT:SLOT907
:SRATe907
:TRIGger:TYPE908

Contents

:TRIGger:TYPE:CONTInuous[:TYPE]	909
:TRIGger:TYPE:GATE:ACTive	910
:TRIGger[:SOURce]	910
:TRIGger[:SOURce]:EXTernal:DELay	911
:TRIGger[:SOURce]:EXTernal:DELay:STATe	912
:TRIGger[:SOURce]:EXTernal:SLOPe	912
:TRIGger[:SOURce]:EXTernal[:SOURce]	912
	914
PDC Subsystem–Option 402 ([:SOURce]:RADio:PDC)	915
:ALPha	915
:BBCLock	915
:BBT	916
:BRATe	916
:BURSt:PN9	917
:BURSt:SHAPE:FALL:DELay	918
:BURSt:SHAPE:FALL:TIME	918
:BURSt:SHAPE:FDELay	919
:BURSt:SHAPE:FTIME	920
:BURSt:SHAPE:RDELay	920
:BURSt:SHAPE:RISE:DELay	921
:BURSt:SHAPE:RISE:TIME	922
:BURSt:SHAPE:RTIME	922
:BURSt:SHAPE[:TYPE]	923
:BURSt[:STATe]	923
:CHANnel	924
:DATA	924
:DATA:PRAM	925
:DATA:FIX4	925
:DEFault	925
:EDATa:DELay	926
:EDCLock	926
:EREFerence	926
:EREFerence:VALue	927
:FILTer	927
:FRATe	928
:IQ:SCALE	928
:MODulation:FSK[:DEViation]	929
:MODulation:MSK[:PHASe]	929

:MODulation:UFSK	930
:MODulation:UIQ	930
:MODulation[:TYPE]	930
:POLarity[:ALL]	931
:SECondary:RECall	931
:SECondary:SAVE	931
:SECondary:TRIGger[:SOURce]	932
:SECondary[:STATe]	932
:SLOT0[1]2 3 4 5:DCUStom	933
:SLOT0[1]2 3 4 5:DCUSTom:FIX4	933
:SLOT0[1]2 3 4 5:DTCHannel:CCODE	933
:SLOT0[1]2 3 4 5:DTCHannel:SACChannel	934
:SLOT0[1]2 3 4 5:DTCHannel:SWORd	934
:SLOT0[1]2 3 4 5:DTCHannel[:TCHannel]	934
:SLOT0[1]2 3 4 5:DTCHannel[:TCHannel]:FIX4	935
:SLOT0[1]2 3 4:POWer	935
:SLOT0[1]2 3 4 5:STATe	936
:SLOT0[1]2 3 4 5:UCUStom	936
:SLOT0[1]2 3 4 5:UCUStom:FIX4	936
:SLOT0[1]2 3 4 5:UTCHannel:CCODE	937
:SLOT0[1]2 3 4 5:UTCHannel:SACChannel	937
:SLOT0[1]2 3 4 5:UTCHannel:SWORd	937
:SLOT0[1]2 3 4 5:UTCHannel[:TCHannel]	938
:SLOT0[1]2 3 4 5:UTCHannel[:TCHannel]:FIX4	938
:SLOT0[1]2 3 4 5:UVOX:CCODE	939
:SLOT0[1]2 3 4 5:UVOX:SACChannel	939
:SLOT0[1]2 3 4 5:UVOX:SWORd	939
:SLOT0[1]2 3 4 5[:TYPE]	940
:SOUT	940
:SOUT:OFFSet	940
:SOUT:SLOT	941
:SRATe	941
:TRIGger:TYPE	943
:TRIGger:TYPE:CONTInuous[:TYPE]	943
:TRIGger:TYPE:GATE:ACTive	944
:TRIGger[:SOURce]	944
:TRIGger[:SOURce]:EXTernal:DELay	945
:TRIGger[:SOURce]:EXTernal:DELay:STATe	946

Contents

:TRIGger[:SOURce]:EXTernal:SLOPe	946
:TRIGger[:SOURce]:EXTernal[:SOURce]	947
[:STATe]	947
PHS Subsystem–Option 402 ([:SOURce]:RADio:PHS)	948
:ALPha	948
:BBCLock	948
:BBT	949
:BRATe	949
:BURSt:PN9	950
:BURSt:SCRamble:SEED	951
:BURSt:SCRamble[:STATe]	951
:BURSt:SHAPe:FALL:DELay	952
:BURSt:SHAPe:FALL:TIME	952
:BURSt:SHAPe:FDELay	953
:BURSt:SHAPe:FTIME	954
:BURSt:SHAPe:RDELay	954
:BURSt:SHAPe:RISE:DELay	955
:BURSt:SHAPe:RISE:TIME	956
:BURSt:SHAPe:RTIME	956
:BURSt:SHAPe[:TYPE]	957
:BURSt[:STATe]	957
:CHANnel	958
:DATA	958
:DATA:PRAM.	959
:DATA:FIX4	959
:DEFault	959
:DLINK:SLOT[1] 2 3 4:CUSTom	960
:DLINK:SLOT[1] 2 3 4:CUSTom:FIX4	960
:DLINK:SLOT[1] 2 3 4:POWer	960
:DLINK:SLOT[1] 2 3 4:SCHannel:CSID	961
:DLINK:SLOT[1] 2 3 4:SCHannel:IDLE	961
:DLINK:SLOT[1] 2 3 4:SCHannel:PSID	961
:DLINK:SLOT[1] 2 3 4:SCHannel:UWORD.	962
:DLINK:SLOT[1] 2 3 4:STATe	962
:DLINK:SLOT[1] 2 3 4:TCHannel:SACChannel	962
:DLINK:SLOT[1] 2 3 4:TCHannel:UWORD.	963
:DLINK:SLOT[1] 2 3 4:TCHannel[:TCHannel]	963
:DLINK:SLOT[1] 2 3 4:TCHannel[:TCHannel]:FIX4	963

:DLINK:SLOT[1] 2 3 4[:TYPE]	.964
:EDATa:DELay	.964
:EDCLock	.964
:EREFerence	.965
:EREFerence:VALue	.965
:FILTer	.966
:IQ:SCALE	.967
:MODulation:FSK[:DEViation]	.967
:MODulation:MSK[:PHASe]	.968
:MODulation:UFSK	.968
:MODulation:UIQ	.968
:MODulation[:TYPE]	.969
:POLarity[:ALL]	.969
:SECondary:RECall	.969
:SECondary:SAVE	.970
:SECondary:TRIGger[:SOURce]	.970
:SECondary[:STATe]	.970
:SOUT	.971
:SOUT:OFFSet	.971
:SOUT:SLOT	.972
:SRATe	.972
:TRIGger:TYPE	.973
:TRIGger:TYPE:CONTinuous[:TYPE]	.974
:TRIGger:TYPE:GATE:ACTive	.975
:TRIGger[:SOURce]:EXTernal:DELay	.975
:TRIGger[:SOURce]:EXTernal:DELay:STATe	.976
:TRIGger[:SOURce]:EXTernal:SLOPe	.976
:TRIGger[:SOURce]:EXTernal[:SOURce]	.976
:TRIGger[:SOURce]	.977
:ULINK:SLOT[1] 2 3 4:CUSTom	.978
:ULINK:SLOT[1] 2 3 4:CUSTom:FIX4	.979
:ULINK:SLOT[1] 2 3 4:POWer	.979
:ULINK:SLOT[1] 2 3 4:SCHannel:CSID	.979
:ULINK:SLOT[1] 2 3 4:SCHannel:IDLE	.980
:ULINK:SLOT[1] 2 3 4:SCHannel:PSID	.980
:ULINK:SLOT[1] 2 3 4:SCHannel:UWORd	.980
:ULINK:SLOT[1] 2 3 4:STATe	.981
:ULINK:SLOT[1] 2 3 4:TCHannel:SACChannel	.981

Contents

:ULINK:SLOT[1] 2 3 4:TCHannel:UWORD.	981
:ULINK:SLOT[1] 2 3 4:TCHannel[:TCHannel]	982
:ULINK:SLOT[1] 2 3 4:TCHannel[:TCHannel:FIX4]	982
:ULINK:SLOT[1] 2 3 4[:TYPE]	982
[:STATe]	983
TETRA Subsystem–Option 402 ([:SOURce]:RADio:TETRa)	984
:ALPha	984
:BBCLock	984
:BBT	985
:BRATe	985
:BURSt:PN9	986
:BURSt:SCRamble:SEED	987
:BURSt:SCRamble[:STATe].	987
:BURSt:SHAPe:FALL:DELay	987
:BURSt:SHAPe:FALL:TIME	988
:BURSt:SHAPe:FDELay	989
:BURSt:SHAPe:FTIME	989
:BURSt:SHAPe:RDELay	990
:BURSt:SHAPe:RISE:DELay	991
:BURSt:SHAPe:RISE:TIME	991
:BURSt:SHAPe:RTIME	992
:BURSt:SHAPe[:TYPE].	993
:BURSt[:STATe]	993
:CHANnel	994
:DATA	994
:DATA:PRAM.	995
:DATA:FIX4	995
:DEFault	996
:EDATa:DELay	996
:EDCLock	996
:EREFerence	997
:EREFerence:VALue.	997
:FILTer	998
:IQ:SCALE	999
:MODulation:FSK[:DEViation]	999
:MODulation:MSK[:PHASe]	1000
:MODulation:UFSK	1000
:MODulation:UIQ.	1000

:MODulation[:TYPE]	1001
:POLarity[:ALL]	1001
:SECondary:RECall	1002
:SECondary:SAVE	1002
:SECondary:TRIGger[:SOURce]	1002
:SECondary[:STATe].	1003
:SLOT[1] 2 3 4:DCCustom	1003
:SLOT[1] 2 3 4:DCCustom:FIX4	1003
:DCNormal:B1	1004
:DCNormal:B2	1004
:SLOT[1] 2 3 4:DCNormal:TSEquence	1004
:SLOT[1] 2 3 4:DCNormal[:DATA]	1005
:SLOT[1] 2 3 4:DCNormal[:DATA]:FIX4	1005
:SLOT[1] 2 3 4:DCSync:B	1006
:SLOT[1] 2 3 4:DCSync:FCOR	1006
:SLOT[1] 2 3 4:DCSync:SSB	1006
:SLOT[1] 2 3 4:DCSync:STS	1007
:SLOT[1] 2 3 4:DCSync[:DATA]	1007
:SLOT[1] 2 3 4:DCSync[:DATA]:FIX4	1007
:SLOT[1] 2 3 4:DDCustom	1008
:SLOT[1] 2 3 4:DDCustom:FIX4	1008
:SLOT[1] 2 3 4:DDNormal:B1	1009
:SLOT[1] 2 3 4:DDNormal:B2	1009
:SLOT[1] 2 3 4:DDNormal:TSEquence	1009
:SLOT[1] 2 3 4:DDNormal[:DATA]	1010
:SLOT[1] 2 3 4:DDNormal[:DATA]:FIX4	1010
:SLOT[1] 2 3 4:DDSync:B	1011
:SLOT[1] 2 3 4:DDSync:FCOR	1011
:SLOT[1] 2 3 4:DDSync:SSB	1011
:SLOT[1] 2 3 4:DDSync:STS	1012
:SLOT[1] 2 3 4:DDSync[:DATA]	1012
:SLOT[1] 2 3 4:DDSync[:DATA]:FIX4	1012
:SLOT[1] 2 3 4:POWEr	1013
:SLOT[1] 2 3 4:STATe.	1013
:SLOT[1] 2 3 4:UC1:TSEquence	1013
:SLOT[1] 2 3 4:UC1[:DATA]	1014
:SLOT[1] 2 3 4:UC1[:DATA]:FIX4	1014
:SLOT[1] 2 3 4:UC2:TSEquence	1014

Contents

:SLOT[1] 2 3 4:UC2[:DATA]	1015
:SLOT[1] 2 3 4:UC2[:DATA]:FIX4	1015
:SLOT[1] 2 3 4:UCUStom	1015
:SLOT[1] 2 3 4:UCUStom:FIX4	1016
:SLOT[1] 2 3 4:UNORmal:TSEquence	1016
:SLOT[1] 2 3 4:UNORmal[:DATA]	1016
:SLOT[1] 2 3 4:UNORmal[:DATA]:FIX4	1017
:SLOT[1] 2 3 4[:TYPE]	1017
:SOUT	1019
:SOUT:OFFSet	1019
:SOUT:SLOT	1020
:SRATe	1020
:TRIGger:TYPE	1022
:TRIGger:TYPE:CONTInuous[:TYPE]	1022
:TRIGger:TYPE:GATE:ACTive	1023
:TRIGger[:SOURce]	1024
:TRIGger[:SOURce]:EXTernal:DELay	1025
:TRIGger[:SOURce]:EXTernal:DELay:STATe	1025
:TRIGger[:SOURce]:EXTernal:SLOPe	1026
:TRIGger[:SOURce]:EXTernal[:SOURce]	1026
[:STATe]	1027
Wideband CDMA Base Band Generator Subsystem–Option 400	
([:SOURce]:RADio:WCDMa:TGPP[:BBG])	1028
:BBCLock	1028
:BBCLock:EXT:RATE	1028
:DLINK:APPLy	1029
:DLINK:AWGN:CN	1029
:DLINK:AWGN:CPOWer	1029
:DLINK:AWGN:ECNO	1030
:DLINK:AWGN:ECRPower	1030
:DLINK:AWGN:ECRef	1030
:DLINK:AWGN:FNBW	1031
:DLINK:AWGN:NPOWer	1031
:DLINK:AWGN:TICPower	1031
:DLINK:AWGN[:STATe]	1032
:DLINK:BBCLock	1032
:DLINK:CARB:CMODE:CCODE	1032
:DLINK:CARB:CMODE:DATA	1033
:DLINK:CARB:CMODE:FOFFset	1033

:DLINK:CARB:CMODE:FSTRuct	1033
:DLINK:CARB:CMODE:POWer.	1034
:DLINK:CARB:CMODE:PRATio	1034
:DLINK:CARB:CMODE:SCTYpe.	1034
:DLINK:CARB:CMODE:SFORmat	1035
:DLINK:CARB:CMODE:SSCodeos	1035
:DLINK:CARB:CMODE:TFIRst.	1036
:DLINK:CARB:CMODE:TGL	1036
:DLINK:CARB:CMODE[:STATe].	1036
:DLINK:CPICH:CCODE	1037
:DLINK:CPICH:POWer	1037
:DLINK:CPICH[:STATe]	1037
:DLINK:CRATe	1038
:DLINK:DPCH[1]:BALance	1038
:DLINK:DPCH[1]:BINitalize	1038
:DLINK:DPCH[1]2:ALL[:STATe]	1039
:DLINK:DPCH[1]2:CCODE.	1039
:DLINK:DPCH[1]2:DATA	1039
:DLINK:DPCH[1]2:DATA:FIX4	1040
:DLINK:DPCH[1]2:POWer	1040
:DLINK:DPCH[1]2:RCSetup.	1041
:DLINK:DPCH[1]2:SLOTformat	1042
:DLINK:DPCH[1]2:SRATe.	1042
:DLINK:DPCH[1]2:SSCodeos	1042
:DLINK:DPCH[1]2:TFCI:PATtern	1043
:DLINK:DPCH[1]2:TOFFset	1043
:DLINK:DPCH[1]2:TPC:NUMSteps	1044
:DLINK:DPCH[1]2:TPC:PATtern	1044
:DLINK:DPCH[1]2[:STATe]	1045
:DLINK:FILTer	1045
:DLINK:FILTer:ALPHa.	1046
:DLINK:FILTer:BBT	1046
:DLINK:FILTer:CHANnel.	1047
:DLINK:MSYNc	1047
:DLINK:OCNS[1]2 3 4 5 6 7 8 9 10 11 12 13 14 15 16:ALL[:STATe].	1047
:DLINK:OCNS[1]2 3 4 5 6 7 8 9 10 11 12 13 14 15 16:CCODE	1048
:DLINK:OCNS[1]2 3 4 5 6 7 8 9 10 11 12 13 14 15 16:DATA	1048
:DLINK:OCNS[1]2 3 4 5 6 7 8 9 10 11 12 13 14 15 16:POWer.	1048

Contents

:DLINK:OCNS[1] 2 3 4 5 6 7 8 9 10 11 12 13 14 15 16:SRATe	1049
:DLINK:OCNS[1] 2 3 4 5 6 7 8 9 10 11 12 13 14 15 16:SSCodeos	1049
:DLINK:OCNS[1] 2 3 4 5 6 7 8 9 10 11 12 13 14 15 16:TOFFset	1050
:DLINK:OCNS[1] 2 3 4 5 6 7 8 9 10 11 12 13 14 15 16[:STATe]	1050
:DLINK:OOSTest[:STATe]	1050
:DLINK:OOSTest:DTXGate:POLarity	1051
:DLINK:PADJust	1051
:DLINK:PCCPch:BCHData	1051
:DLINK:PCCPch:BCHData:FIX4	1052
:DLINK:PCCPch:CCODE	1052
:DLINK:PCCPch:POWer	1052
:DLINK:PCCPch[:STATe]	1053
:DLINK:PICH:CCODE	1053
:DLINK:PICH:DATA	1053
:DLINK:PICH:DATA:FIX4	1054
:DLINK:PICH:PIBits	1054
:DLINK:PICH:PINDicator	1054
:DLINK:PICH:POWer	1055
:DLINK:PICH[:STATe]	1055
:DLINK:POLarity	1055
:DLINK:PSCH:POWer	1056
:DLINK:PSCH[:STATe]	1056
:DLINK:RPANel:INPut:ALTPower	1056
:DLINK:RPANel:INPut:BBGRef	1057
:DLINK:RPANel:INPut:BGATe	1057
:DLINK:RPANel:INPut:PTRigger1	1057
:DLINK:RPANel:INPut:PTRigger2	1058
:DLINK:RPANel:OUTPut:DCLock	1058
:DLINK:RPANel:OUTPut:DOUT	1060
:DLINK:RPANel:OUTPut:EVENT1	1061
:DLINK:RPANel:OUTPut:EVENT2	1061
:DLINK:RPANel:OUTPut:EVENT3	1062
:DLINK:RPANel:OUTPut:EVENT4	1062
:DLINK:RPANel:OUTPut:SSYNc	1063
:DLINK:SCH[:STATe]	1063
:DLINK:SCRamblecode	1063
:DLINK:SDElay	1064
:DLINK:SSCH:POWer	1064

:DLINK:SSCH:SSGRoup	1064
:DLINK:SSCH[:STATe]	1065
:DLINK:TGAP:FSTRuct	1065
:DLINK:TGAP:POFFset	1065
:DLINK:TGAP:PSI[1]:CFN	1066
:DLINK:TGAP:PSI[1]:CMMethod	1066
:DLINK:TGAP:PSI[1]:D	1067
:DLINK:TGAP:PSI[1]:L1	1067
:DLINK:TGAP:PSI[1]:L2	1067
:DLINK:TGAP:PSI[1]:PL1	1068
:DLINK:TGAP:PSI[1]:PL2	1068
:DLINK:TGAP:PSI[1]:PRC	1068
:DLINK:TGAP:PSI[1]:PS	1069
:DLINK:TGAP:PSI[1]:SN	1069
:DLINK:TGAP:RPARameter	1069
:DLINK:TGAP:SCFN	1070
:DLINK:TGAP:START:TRIGger	1070
:DLINK:TGAP:START:TRIGger:POLarity	1070
:DLINK:TGAP:STOP:TRIGger	1071
:DLINK:TGAP:STOP:TRIGger:POLarity	1071
:DLINK:TGAP[:STATe]	1071
:DLINK:TSETup	1072
:DLINK:TXDV	1073
:DLINK[:TGRoup [A] B]:DCH[1] 2 3 4 5 6:BLKSize	1074
:DLINK[:TGRoup [A] B]:DCH[1] 2 3 4 5 6:BPFRame	1075
:DLINK[:TGRoup [A] B]:DCH[1] 2 3 4 5 6:BRATe	1075
:DLINK[:TGRoup [A] B]:DCH[1] 2 3 4 5 6:BSSize	1075
:DLINK[:TGRoup [A] B]:DCH[1] 2 3 4 5 6:CODE	1076
:DLINK[:TGRoup [A] B]:DCH[1] 2 3 4 5 6:CRC	1077
:DLINK[:TGRoup [A] B]:DCH[1] 2 3 4 5 6:DATA	1077
:DLINK[:TGRoup [A] B]:DCH[1] 2 3 4 5 6:DATA:EINsert	1078
:DLINK[:TGRoup [A] B]:DCH[1] 2 3 4 5 6:DATA:FIX4	1078
:DLINK[:TGRoup [A] B]:DCH[1] 2 3 4 5 6:NBLocks	1079
:DLINK[:TGRoup [A] B]:DCH[1] 2 3 4 5 6:POSition	1081
:DLINK[:TGRoup [A] B]:DCH[1] 2 3 4 5 6:PPERcentage	1081
:DLINK[:TGRoup [A] B]:DCH[1] 2 3 4 5 6:RMATch	1082
:DLINK[:TGRoup [A] B]:DCH[1] 2 3 4 5 6:TTI	1082
:DLINK[:TGRoup [A] B]:DCH[1] 2 3 4 5 6[:STATe]	1083

Contents

:LINK	1083
:POLarity[:ALL].	1083
:ULINK:APPLY	1084
:ULINK:AWGN:CN	1084
:ULINK:AWGN:CPOWer	1085
:ULINK:AWGN:DRATe	1085
:ULINK:AWGN:EBNO	1085
:ULINK:AWGN:EBRef.	1086
:ULINK:AWGN:FNBW	1086
:ULINK:AWGN:NPOWer	1087
:ULINK:AWGN:TICPower.	1087
:ULINK:AWGN[:STATe]	1087
:ULINK:CRATe.	1088
:ULINK:DPCCh:BETA	1088
:ULINK:DPCCh:CCODE	1089
:ULINK:DPCCh:DATA.	1089
:ULINK:DPCCh:DATA:FIX4	1090
:ULINK:DPCCh:FBI:PATtern	1090
:ULINK:DPCCh:FBI:PATtern:FIX	1091
:ULINK:DPCCh:FBI[:STATe]	1091
:ULINK:DPCCh:POWer	1092
:ULINK:DPCCh:RATE	1092
:ULINK:DPCCh:SLOTformat	1092
:ULINK:DPCCh:TFCI:PATtern	1093
:ULINK:DPCCh:TFCI:PATtern:FIX	1093
:ULINK:DPCCh:TFCI[:STATe]	1094
:ULINK:DPCCh:TPC:NSTeps	1094
:ULINK:DPCCh:TPC:PATtern.	1095
:ULINK:DPCCh:TPC:PATtern:FIX4	1096
:ULINK:DPCCh:TPC:PATtern:TRIGger:POLarity	1096
:ULINK:DPCCh:TPC:PATtern:TRIGger[:STATe].	1097
:ULINK:DPCCh:TPOWer	1097
:ULINK:DPCCh[:STATe]	1098
:ULINK:DPDCh:BETA.	1098
:ULINK:DPDCh:CCODE	1099
:ULINK:DPDCh:DATA.	1100
:ULINK:DPDCh:DATA:FIX4	1100
:ULINK:DPDCh:POWer	1101

:ULINK:DPDCh:RATE	1101
:ULINK:DPDCh:RBER	1102
:ULINK:DPDCh:SLOTformat	1103
:ULINK:DPDCh:TBER[:CLENgth]	1104
:ULINK:DPDCh:TBER:ELENgth	1104
:ULINK:DPDCh:TPOWer	1105
:ULINK:DPDCh[:STATe]	1105
:ULINK:FCLock:INTerval	1105
:ULINK:FCLock:POLarity	1106
:ULINK:FILTer	1106
:ULINK:FILTer:ALPHA	1107
:ULINK:FILTer:BBT	1108
:ULINK:FILTer:CHANnel	1108
:ULINK:FOFFset	1109
:ULINK:PADJust	1109
:ULINK:PHYSical[1]:TYPE	1109
:ULINK:PMODE:TPControl:HOLD	1110
:ULINK:PMODE:TPControl:POWER:INITial	1110
:ULINK:PMODE:TPControl:POWER:MAXimum	1111
:ULINK:PMODE:TPControl:POWER:MINimum	1111
:ULINK:PMODE:TPControl:POWER:RESet	1112
:ULINK:PMODE:TPControl:POWER:STEP	1112
:ULINK:PMODE:TPControl:TRIGger:POLarity	1113
:ULINK:PMODE[:SElect]	1113
:ULINK:PRACH:AICH:NUMBER	1113
:ULINK:PRACH:AICH:POLarity	1114
:ULINK:PRACH:AWGN:CN	1114
:ULINK:PRACH:AWGN:CPOWer	1115
:ULINK:PRACH:AWGN:DRATE	1115
:ULINK:PRACH:AWGN:EBNO	1115
:ULINK:PRACH:AWGN:ECNO	1116
:ULINK:PRACH:AWGN:EREF	1116
:ULINK:PRACH:AWGN:NPOWer	1117
:ULINK:PRACH:AWGN:TICPower	1117
:ULINK:PRACH:AWGN[:STATe]	1117
:ULINK:PRACH:MESSAge:CPART:BETA	1118
:ULINK:PRACH:MESSAge:CPART:DATA	1118
:ULINK:PRACH:MESSAge:CPART:DATA:FIX4	1119

Contents

:ULINK:PRACH:MESSAge:CPART:POWer	1119
:ULINK:PRACH:MESSAge:CPART:RATE	1120
:ULINK:PRACH:MESSAge:CPART:SLOTformat	1120
:ULINK:PRACH:MESSAge:CPART:TFCI:PATtern	1121
:ULINK:PRACH:MESSAge:CPART:TFCI:PATtern:FIX	1121
:ULINK:PRACH:MESSAge:CPART:TFCI[:STATe].	1122
:ULINK:PRACH:MESSAge:DPART:BETA	1122
:ULINK:PRACH:MESSAge:DPART:DATA	1123
:ULINK:PRACH:MESSAge:DPART:DATA:FIX4	1123
:ULINK:PRACH:MESSAge:DPART:POWer	1124
:ULINK:PRACH:MESSAge:DPART:RATE	1124
:ULINK:PRACH:MESSAge:DPART:SLOTformat.	1125
:ULINK:PRACH:MODE[:SElect]	1126
:ULINK:PRACH:MULTi:MESSAge:TPOWer.	1127
:ULINK:PRACH:MULTi:MESSAge[:STATe]	1127
:ULINK:PRACH:MULTi:NUMBer.	1127
:ULINK:PRACH:MULTi:PREamble:NUMBer.	1128
:ULINK:PRACH:MULTi:PREamble:POWer:INITial	1128
:ULINK:PRACH:MULTi:PREamble:POWer:MAX	1129
:ULINK:PRACH:MULTi:PREamble:POWer:RStep	1129
:ULINK:PRACH:MULTi:PREamble:PPM	1129
:ULINK:PRACH:MULTi:UE[1] 2 3 4 5 6 7 8:MESSAge:CPART:CCODE	1130
:ULINK:PRACH:MULTi:UE[1] 2 3 4 5 6 7 8:MESSAge:DPART:CCODE	1130
:ULINK:PRACH:MULTi:UE[1] 2 3 4 5 6 7 8:PREamble:SIGNature	1130
:ULINK:PRACH:MULTi:UE[1] 2 3 4 5 6 7 8:SPOsition[1] 2 3 4 5 6 7 8[:ASLot]	1131
:ULINK:PRACH:MULTi:UE[1] 2 3 4 5 6 7 8[:STATe]	1132
:ULINK:PRACH:PREamble:POWer:AVERAge	1132
:ULINK:PRACH:PREamble:POWer:MODE	1133
:ULINK:PRACH:RPARAmeter	1133
:ULINK:PRACH:SCRamblecode	1134
:ULINK:PRACH:SDElay	1134
:ULINK:PRACH:SUBChannel	1135
:ULINK:PRACH:TOFFset	1135
:ULINK:PRACH:TPA	1136
:ULINK:PRACH:TPM.	1136
:ULINK:PRACH:TPOWer.	1137
:ULINK:PRACH:TPP	1137
:ULINK:PRACH:TRIGger.	1138

:ULINK:PRACH:TRIGGER:POLarity	1138
:ULINK:PRACH:TRIGGER:SOURce	1138
:ULINK:PRACH:TTI	1139
:ULINK:PRACH[:SINGle]:MESSAge[:STATe]	1139
:ULINK:PRACH[:SINGle]:NUMBer	1140
:ULINK:PRACH[:SINGle]:MESSAge:CPARt:CCODE	1140
:ULINK:PRACH[:SINGle]:MESSAge:DPARt:CCODE	1141
:ULINK:PRACH[:SINGle]:MESSAge:TPOWer	1142
:ULINK:PRACH[:SINGle]:NUMBer	1142
:ULINK:PRACH[:SINGle]:PREamble:NUMBer	1143
:ULINK:PRACH[:SINGle]:PREamble:POWer:INITial	1143
:ULINK:PRACH[:SINGle]:PREamble:POWer:MAX	1144
:ULINK:PRACH[:SINGle]:PREamble:POWer:RSTep	1144
:ULINK:PRACH[:SINGle]:PREamble:PPM	1145
:ULINK:PRACH[:SINGle]:PREamble:SIGNature	1145
:ULINK:RMCHannel	1146
:ULINK:RPANel:DPCH:INPut:ALTPower	1146
:ULINK:RPANel:DPCH:INPut:BBGRef	1147
:ULINK:RPANel:DPCH:INPut:BGATe	1147
:ULINK:RPANel:DPCH:INPut:PTRigger1	1147
:ULINK:RPANel:DPCH:INPut:PTRigger2	1148
:ULINK:RPANel:DPCH:OUTPut:DCLock	1148
:ULINK:RPANel:DPCH:OUTPut:DOUt	1149
:ULINK:RPANel:DPCH:OUTPut:EvENt1	1150
:ULINK:RPANel:DPCH:OUTPut:EvENt2	1150
:ULINK:RPANel:DPCH:OUTPut:EvENt3	1151
:ULINK:RPANel:DPCH:OUTPut:EvENt4	1151
:ULINK:RPANel:DPCH:OUTPut:SSYNc	1152
:ULINK:RPANel:PRACH:INPut:ALTPower	1152
:ULINK:RPANel:PRACH:INPut:BBGRef	1153
:ULINK:RPANel:PRACH:INPut:BGATe	1153
:ULINK:RPANel:PRACH:INPut:PTRigger1	1153
:ULINK:RPANel:PRACH:INPut:PTRigger2	1154
:ULINK:RPANel:PRACH:OUTPut:DCLock	1154
:ULINK:RPANel:PRACH:OUTPut:DOUt	1156
:ULINK:RPANel:PRACH:OUTPut:EvENt1	1156
:ULINK:RPANel:PRACH:OUTPut:EvENt2	1157
:ULINK:RPANel:PRACH:OUTPut:EvENt3	1158

Contents

:ULINK:RPANel:PRACH:OUTPut:EVENT4	1158
:ULINK:RPANel:PRACH:OUTPut:SSYNc	1159
:ULINK:SCRamblecode	1160
:ULINK:SDElay	1160
:ULINK:SFNRst:POLarity	1160
:ULINK:SYNC:MODE	1161
:ULINK:SYNC[:SOURce]	1161
:ULINK:TGAP:POFFset	1163
:ULINK:TGAP:PSI[1] 2 3 4 5 6:CFN	1163
:ULINK:TGAP:PSI[1]:CMMethod	1164
:ULINK:TGAP:PSI[1] 2 3 4 5 6:D	1164
:ULINK:TGAP:PSI[1] 2 3 4 5 6:L1	1165
:ULINK:TGAP:PSI[1] 2 3 4 5 6:L2	1165
:ULINK:TGAP:PSI[1] 2 3 4 5 6:PL1	1165
:ULINK:TGAP:PSI[1] 2 3 4 5 6:PL2	1166
:ULINK:TGAP:PSI[1] 2 3 4 5 6:POWer	1166
:ULINK:TGAP:PSI[1] 2 3 4 5 6:PRC	1166
:ULINK:TGAP:PSI[1] 2 3 4 5 6:PS	1167
:ULINK:TGAP:PSI[1] 2 3 4 5 6:SN	1167
:ULINK:TGAP:RPARameter	1167
:ULINK:TGAP:SCFN	1168
:ULINK:TGAP[:STATE]	1168
:ULINK:TGAP:START:TRIGger	1169
:ULINK:TGAP:START:TRIGger:POLarity	1169
:ULINK:TGAP:STOP:TRIGger	1169
:ULINK:TGAP:STOP:TRIGger:POLarity	1169
:ULINK:TOFFset	1170
:ULINK:TSTatus:COMPressed	1170
:ULINK:TSTatus:RACH	1170
:ULINK:TSTatus:RECeive	1171
:ULINK:TSTatus:SYNC	1171
:ULINK:[TGRoup[1]]:DCH[1] 2 3 3 5 6:BLKSize	1171
:ULINK[:TGRoup[1]]:DCH[1] 2 3 4 5 6:BPFRame	1172
:ULINK[:TGRoup[1]]:DCH[1] 2 3 4 5 6:BRATe	1172
:ULINK:[TGRoup[1]]:DCH[1] 2 3 3 5 6:CODE	1172
:ULINK:[TGRoup[1]]:DCH[1] 2 3 3 5 6:CRC	1173
:ULINK:[TGRoup[1]]:DCH[1] 2 3 3 5 6:DATA	1173
:ULINK[:TGRoup[1]]:DCH[1] 2 3 4 5 6:DATA:BER:ACTual	1174

:ULINK[:TGRoup[1]]:DCH[1]2 3 4 5 6:DATA:BER:ERRor:BIT	1174
:ULINK[:TGRoup[1]]:DCH[1]2 3 4 5 6:DATA:BER:TOTal:BIT	1174
:ULINK[:TGRoup[1]]:DCH[1]2 3 4 5 6:DATA:BER[:VALue]	1175
:ULINK[:TGRoup[1]]:DCH[1]2 3 4 5 6:DATA:BLER:ACTual.	1175
:ULINK[:TGRoup[1]2]:DCH[1]2 3 4 5 6:DATA:BLER:ERRor:BLOCK	1175
:ULINK[:TGRoup[1]2]:DCH[1]2 3 4 5 6:DATA:BLER:TOTal:BLOCK	1176
:ULINK[:TGRoup[1]]:DCH[1]2 3 4 5 6:DATA:BLER[:VALue]	1176
:ULINK[:TGRoup[1]]:DCH[1]2 3 4 5 6:DATA:EINsert	1177
:ULINK[:TGRoup[1]]:DCH[1]2 3 4 5 6:DATA:FIX4.	1177
:ULINK[:TGRoup[1]]:DCH[1]2 3 4 5 6:NBLock.	1178
:ULINK[:TGRoup [1]]:DCH[1]2 3 4 5 6:PPERcentage	1178
:ULINK[:TGRoup[1]]:DCH[1]2 3 4 5 6:RMATch	1178
:ULINK[:TGRoup[1]]:DCH[1]2 3 4 5 6:TTI	1179
:ULINK[:TGRoup[1]]:DCH[1]2 3 4 5 6[:STATe].....	1179
:ULINK[:TGRoup[1]]:RACH[1]:BLKSize.	1179
:ULINK[:TGRoup [1]]:RACH[1]:BPFRAme	1180
:ULINK[:TGRoup [1]]:RACH[1]:BRATe.....	1180
:ULINK[:TGRoup[1]]:RACH[1]:CODE.	1180
:ULINK[:TGRoup[1]]:RACH[1]:CRC	1180
:ULINK[:TGRoup[1]]:RACH[1]:DATA	1181
:ULINK[:TGRoup[1]]:RACH[1]:DATA:BER:ACTual.	1181
:ULINK[:TGRoup[1]]:RACH[1]:DATA:BER:ERRor:BIT	1181
:ULINK[:TGRoup[1]]:RACH[1]:DATA:BER:TOTal:BIT	1182
:ULINK[:TGRoup[1]]:RACH[1]:DATA:BER[:VALue]	1182
:ULINK[:TGRoup[1]]:RACH[1]:DATA:BLER:ACTual	1182
:ULINK[:TGRoup[1]]:RACH[1]:DATA:BLER:ERRor:BLOCK	1183
:ULINK[:TGRoup[1]]:RACH[1]:DATA:BLER:TOTal:BLOCK.....	1183
:ULINK[:TGRoup[1]]:RACH[1]:DATA:BLER[:VALue].	1183
:ULINK[:TGRoup[1]]:RACH[1]:DATA:EINsert	1184
:ULINK[:TGRoup[1]]:RACH[1]:DATA:FIX4	1184
:ULINK[:TGRoup[1]]:RACH[1]:NBLock	1185
:ULINK[:TGRoup [1]]:RACH[1]:PPERcentage.....	1185
:ULINK[:TGRoup[1]]:RACH[1]:RMATch	1185
:ULINK[:TGRoup[1]]:RACH[1]:TTI	1186
:ULINK[:TGRoup[1]]:RACH[1][:STATe]	1186
[:STATe]	1186

Contents

Documentation Overview

Installation Guide

- Safety Information
- Getting Started
- Operation Verification
- Regulatory Information

User's Guide

- E4428C Analog Signal Generator Overview
- E4423C Analog Signal Generator Overview
- Basic Operation
- Basic Digital Operation
- AWGN Waveform Generator
- Analog Modulation
- Digital Signal Interface Module
- Bluetooth Signals
- BERT
- CDMA Digital Modulation
- GPS Modulation
- Multitone Waveform Generator
- Custom Digital Modulation
- Real Time TDMA Formats
- W-CDMA Digital Modulation for Component Test
- W-CDMA Uplink Digital Modulation for Receiver Test
- W-CDMA Downlink Digital Modulation for Receiver Test
- Troubleshooting

Programming Guide

- Getting Started with Remote Operation
- Using IO Interfaces
- Programming Examples
- Programming the Status Register System
- Creating and Downloading Waveform Files
- Creating and Downloading User-Data Files

SCPI Reference

Volume 1:

- SCPI Basics
- Basic Function Commands
- System Commands
- Analog Commands
- Component Test Digital Commands

Volume 2:

- Digital Signal Interface Module Commands
- Bit Error Rate Test (BERT) Commands
- Receiver Test Digital Commands

Volume 3:

- Receiver Test Digital Commands (continued)

Compatibility with E44xxB SCPI Commands

- Overview
- E4428C/38C SCPI Commands
- ESG E44xxB Commands
- 8648A/B/C/D Commands
- 8658B, 8657A/B/D/J Programming Codes

Service Guide

- Troubleshooting
- Replaceable Parts
- Assembly Replacement
- Post-Repair Procedures
- Safety and Regulatory

Key and Data Field Reference

Volume 1:

- Symbols, Numerics, A-H

Volume 2:

- Volume 2: I-Z

1 SCPI Basics

This chapter describes how SCPI information is organized and presented in this guide. An overview of the SCPI language is also provided. This Chapter contains the following major sections:

- [“Command Reference Information” on page 2](#)
- [“SCPI Basics” on page 3](#)

Command Reference Information

SCPI Command Listings

The Table of Contents lists the Standard Commands for Programmable Instruments (SCPI) without the parameters. The SCPI subsystem name will generally have the first part of the command in parenthesis that is repeated in all commands within the subsystem. The title(s) beneath the subsystem name is the remaining command syntax. The following example demonstrates this listing:

```
Communication Subsystem (:SYSTem:COMMunicate)
  :PMETer:CHANnel
  :SERial:ECHO
```

The following examples show the complete commands from the above Table of Contents listing:

```
:SYSTem:COMMunicate:PMETer:CHANnel
:SYSTem:COMMunicate:SERial:ECHO
```

Key and Data Field Cross Reference

The index is set up so applicable key and data field names can be cross-referenced to the appropriate SCPI command. There are two headings in the index where the key and data field names can be found:

- individual softkey, hardkey, or data field name
- subsystem name

Supported Field

Within each command section, the Supported heading describes which signal generator configurations are supported by the SCPI command. When “All Models” is shown next to this heading, all signal generator configurations are supported by the SCPI command. When “All with Option xxx” is shown next to this heading, only the stated option(s) is supported.

SCPI Basics

This section describes the general use of the SCPI language for the ESG. It is not intended to teach you everything about the SCPI language; the SCPI Consortium or IEEE can provide that level of detailed information. For a list of the specific commands available for the signal generator, refer to the table of contents.

For additional information, refer to the following publications:

- IEEE Standard 488.1-1987, IEEE Standard Digital Interface for Programmable Instrumentation. New York, NY, 1998.
- IEEE Standard 488.2-1992, IEEE Standard Codes, Formats, Protocols and Command Commands for Use with ANSI/IEEE Standard 488.1-1987. New York, NY, 1998.

Common Terms

The following terms are used throughout the remainder of this section:

Command	A command is an instruction in SCPI consisting of mnemonics (keywords), parameters (arguments), and punctuation. You combine commands to form messages that control instruments.
Controller	A controller is any device used to control the signal generator, for example a computer or another instrument.
Event Command	Some commands are events and cannot be queried. An event has no corresponding setting; it initiates an action at a particular time.
Program Message	A program message is a combination of one or more properly formatted commands. Program messages are sent by the controller to the signal generator.
Query	A query is a special type of command used to instruct the signal generator to make response data available to the controller. A query ends with a question mark. Generally you can query any command value that you set.
Response Message	A response message is a collection of data in specific SCPI formats sent from the signal generator to the controller. Response messages tell the controller about the internal state of the signal generator.

Command Syntax

A typical command is made up of keywords prefixed with colons (:). The keywords are followed by parameters. The following is an example syntax statement:

```
[ :SOURCE ] :POWER [ :LEVEL ] MAXimum|MINimum
```

In the example above, the [:LEVEL] portion of the command immediately follows the :POWER portion with no separating space. The portion following the [:LEVEL], MINimum|MAXimum, are the parameters (argument for the command statement). There is a separating space (white space) between the command and its parameter.

Additional conventions in syntax statements are shown in [Table 1-1](#) and [Table 1-2](#).

Table 1-1 Special Characters in Command Syntax

Characters	Meaning	Example
	A vertical stroke between keywords or parameters indicates alternative choices. For parameters, the effect of the command varies depending on the choice.	[:SOURCE] :AM: MOD DEEP NORMAl DEEP or NORMAl are the choices.
[]	Square brackets indicate that the enclosed keywords or parameters are optional when composing the command. These implied keywords or parameters will be executed even if they are omitted.	[:SOURCE] :FREQUENCY [:CW] ? SOURCE and CW are optional items.
< >	Angle brackets around a word (or words) indicate they are not to be used literally in the command. They represent the needed item.	[:SOURCE] :FREQUENCY: START <val><unit> In this command, the words <val> and <unit> should be replaced by the actual frequency and unit. :FREQUENCY:START 2.5GHZ
{ }	Braces indicate that parameters can optionally be used in the command once, several times, or not at all.	[:SOURCE] :LIST: POWER <val>{ , <val> } a single power listing: LIST:POWER 5 a series of power listings: LIST:POWER 5,10,15,20

Table 1-2 Command Syntax

Characters, Keywords, and Syntax	Example
Upper-case lettering indicates the minimum set of characters required to execute the command.	[:SOURce] :FREQuency [:CW] ?, FREQ is the minimum requirement.
Lower-case lettering indicates the portion of the command that is optional; it can either be included with the upper-case portion of the command or omitted. This is the flexible format principle called forgiving listening. Refer to “Command Parameters and Responses” on page 7 for more information.	:FREQuency Either :FREQ, :FREQuency, or :FREQUENCY is correct.
When a colon is placed between two command mnemonics, it moves the current path down one level in the command tree. Refer to “Command Tree” on page 6 more information on command paths.	:TRIGger:OUTPut:POLarity? TRIGger is the root level keyword for this command.
If a command requires more than one parameter, you must separate adjacent parameters using a comma. Parameters are not part of the command path, so commas do not affect the path level.	[:SOURce] :LIST: DWELL <val>{,<val>}
A semicolon separates two commands in the same program message without changing the current path.	:FREQ 2.5GHZ; :POW 10DBM
White space characters, such as <tab> and <space>, are generally ignored as long as they do not occur within or between keywords. However, you must use white space to separate the command from the parameter, but this does not affect the current path.	:FREQ uency or :POWer :LEVel are not allowed. A <space> between :LEVel and 6.2 is mandatory. :POWer:LEVel 6.2

Command Types

Commands can be separated into two groups: common commands and subsystem commands. [Figure 1-1](#), shows the separation of the two command groups.

Common commands are used to manage macros, status registers, synchronization, and data storage and are defined by IEEE 488.2. They are easy to recognize because they all begin with an asterisk. For example *IDN?, *OPC, and *RST are common commands. Common commands are not part of any subsystem and the signal generator interprets them in the same way, regardless of the current path setting.

Subsystem commands are distinguished by the colon (:). The colon is used at the beginning of a command statement and between keywords, as in :FREQUency[:CW?]. Each command subsystem is a set of commands that roughly correspond to a functional block inside the signal generator. For example, the power subsystem (:POWer) contains commands for power generation, while the status subsystem (:STATus) contains commands for controlling status registers.

Figure 1-1 Command Types

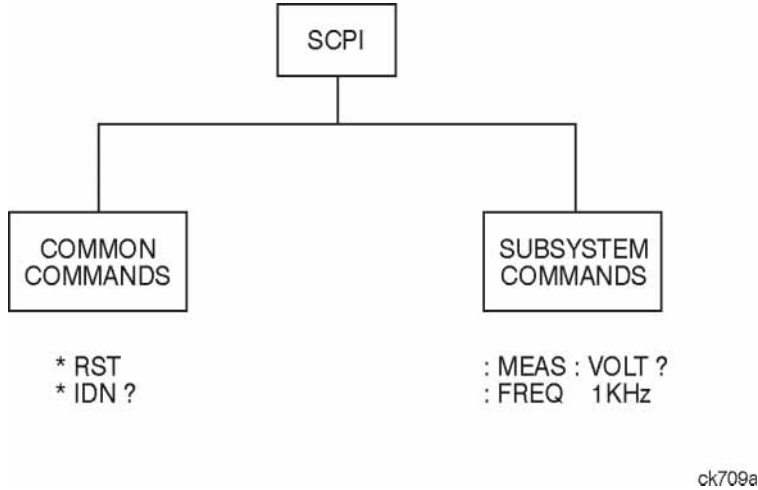

Command Tree

Most programming tasks involve subsystem commands. SCPI uses a structure for subsystem commands similar to the file systems on most computers. In SCPI, this command structure is called a command tree and is shown in Figure 1-2.

Figure 1-2 Simplified Command Tree

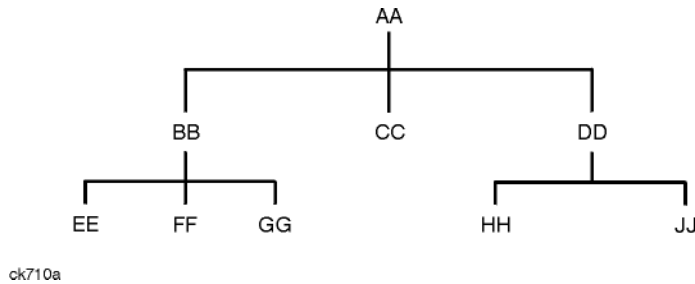

The command closest to the top is the root command, or simply “the root.” Notice that you must follow a particular path to reach lower level commands. In the following example, :POWer represents AA, :ALC

represents BB, :SOURce represents GG. The complete command path is :POWer:ALC:SOURce? (:AA:BB:GG).

Paths Through the Command Tree

To access commands from different paths in the command tree, you must understand how the signal generator interprets commands. The parser, a part of the signal generator firmware, decodes each message sent to the signal generator. The parser breaks up the message into component commands using a set of rules to determine the command tree path used. The parser keeps track of the current path (the level in the command tree) and where it expects to find the next command statement. This is important because the same keyword may appear in different paths. The particular path is determined by the keyword(s) in the command statement.

A message terminator, such as a <new line> character, sets the current path to the root. Many programming languages have output statements that automatically send message terminators.

NOTE The current path is set to the root after the line-power is cycled or when *RST is sent.

Command Parameters and Responses

SCPI defines different data formats for use in program and response messages. It does this to accommodate the principle of forgiving listening and precise talking. For more information on program data types refer to IEEE 488.2.

Forgiving listening means the command and parameter formats are flexible.

For example, with the :FREQuency:REFerence:STATe ON|OFF|1|0 command, the signal generator accepts :FREQuency:REFerence:STATe ON, :FREQuency:REFerence:STATe 1, :FREQ:REF:STAT ON, :FREQ:REF:STAT 1 to turn on the frequency reference mode.

Each parameter type has one or more corresponding response data types. A setting that you program using a numeric parameter returns either real or integer response data when queried. Response data (data returned to the controller) is more concise and restricted, and is called precise talking.

Precise talking means that the response format for a particular query is always the same.

For example, if you query the power state (:POWer:ALC:STATe?) when it is on, the response is always 1, regardless of whether you previously sent :POWer:ALC:STATe 1 or :POWer:ALC:STATe ON. [Table 1-3](#) shows the response for a given parameter type.

Table 1-3 **Parameter and Response Types**

Parameter Types	Response Data Types
Numeric	Real, Integer
Extended Numeric	Real, Integer
Discrete	Discrete
Boolean	Numeric Boolean
String	String

Numeric Parameters

Numeric parameters are used in both common and subsystem commands. They accept all commonly used decimal representations of numbers including optional signs, decimal points, and scientific notation.

If a signal generator setting is programmed with a numeric parameter which can only assume a finite value, it automatically rounds any entered parameter which is greater or less than the finite value. For example, if a signal generator has a programmable output impedance of 50 or 75 ohms, and you specified 76.1 for the output impedance, the value is rounded to 75. The following are examples of numeric parameters:

- 100 no decimal point required
- 100. fractional digits optional
- 1.23 leading signs allowed
- 4.56E<space>3 space allowed after the E in exponential
- 7.89E-001 use either E or e in exponential
- +256 leading + allowed
- .5 digits left of decimal point optional

Extended Numeric Parameters

Most subsystems use extended numeric parameters to specify physical quantities. Extended numeric parameters accept all numeric parameter values and other special values as well.

The following are examples of extended numeric parameters:

100	any simple numeric value
1.2GHZ	GHZ can be used for exponential (E009)
200MHZ	MHZ can be used for exponential (E006)
-100mV	negative 100 millivolts
10DEG	10 degrees

Extended numeric parameters also include the following special parameters:

DEFault	resets the parameter to its default value
UP	increments the parameter
DOWN	decrements the parameter
MINimum	sets the parameter to the smallest possible value
MAXimum	sets the parameter to the largest possible value

Discrete Parameters

Discrete parameters use mnemonics to represent each valid setting. They have a long and a short form, just like command mnemonics. You can mix upper and lower case letters for discrete parameters.

The following examples of discrete parameters are used with the command
`:TRIGger[:SEQUence]:SOURce BUS|IMMEDIATE|EXTernal.`

BUS	GPIB, LAN, or RS-232 triggering
IMMEDIATE	immediate trigger (free run)
EXTernal	external triggering

Although discrete parameters look like command keywords, do not confuse the two. In particular, be sure to use colons and spaces properly. Use a colon to separate command mnemonics from each other and a space to separate parameters from command mnemonics.

The following are examples of discrete parameters in commands:

```
TRIGger:SOURce BUS
TRIGger:SOURce IMMEDIATE
TRIGger:SOURce EXTernal
```

Boolean Parameters

Boolean parameters represent a single binary condition that is either true or false. The two-state boolean parameter has four arguments. The following list shows the arguments for the two-state boolean parameter:

ON	boolean true, upper/lower case allowed
OFF	boolean false, upper/lower case allowed
1	boolean true
0	boolean false

String Parameters

String parameters allow ASCII strings to be sent as parameters. Single or double quotes are used as delimiters.

The following are examples of string parameters:

```
'This is valid'  
"This is also valid"  
'SO IS THIS'
```

Real Response Data

Real response data represent decimal numbers in either fixed decimal or scientific notation. Most high-level programming languages that support signal generator input/output (I/O) handle either decimal or scientific notation transparently.

The following are examples of real response data:

```
+4.000000E+010, -9.990000E+002  
-9.990000E+002  
+4.000000000000000E+010  
+1  
0
```

Integer Response Data

Integer response data are decimal representations of integer values including optional signs. Most status register related queries return integer response data.

The following are examples of integer response data:

0	signs are optional
+100	leading + allowed
-100	leading – allowed
256	never any decimal point

Discrete Response Data

Discrete response data are similar to discrete parameters. The main difference is that discrete response data only returns the short form of a particular mnemonic, in all upper case letters.

The following are examples of discrete response data:

IMM
EXT
INT
NEG

Numeric Boolean Response Data

Boolean response data returns a binary numeric value of one or zero.

String Response Data

String response data are similar to string parameters. The main difference is that string response data returns double quotes, rather than single quotes. Embedded double quotes may be present in string response data. Embedded quotes appear as two adjacent double quotes with no characters between them.

The following are examples of string response data:

```
"This is a string"  
"one double quote inside brackets: ["]"  
"Hello!"
```

Program Messages

The following commands will be used to demonstrate the creation of program messages:

```
[ :SOURce ] :FREQuency :START          [ :SOURce ] :FREQuency :STOP  
[ :SOURce ] :FREQuency [ :CW ]         [ :SOURce ] :POWer [ :LEVe1 ] :OFFSet
```

Example 1

```
:FREQuency :START 500MHZ ; STOP 1000MHZ
```

This program message is correct and will not cause errors; `START` and `STOP` are at the same path level. It is equivalent to sending the following message:

```
FREQuency :START 500MHZ ; FREQuency :STOP 1000MHZ
```

Example 2

```
:POWer 10DBM ; :OFFSet 5DB
```

This program message will result in an error. The message makes use of the default `POWER [:LEVe1]` node (root command). When using a default node, there is no change to the current path position. Since there is no command `OFFSet` at the root level, an error results.

The following example shows the correct syntax for this program message:

```
:POWer 10DBM ; :POWer :OFFSet 5DB
```

Example 3

```
:POWer :OFFSet 5DB ; POWer 10DBM
```

This program message results in a command error. The path is dropped one level at each colon. The first half of the message drops the command path to the lower level command `OFFSet`; `POWer` does not exist at this level.

The `POWER 10DBM` command is missing the leading colon and when sent, it causes confusion because the signal generator cannot find `POWER` at the `POWER :OFFSet` level. By adding the leading colon, the current path is reset to the root. The following shows the correct program message:

```
:POWer :OFFSet 5DB ; :POWer 10DBM
```

Example 4

```
FREQ 500MHZ ; POW 4DBM
```

In this example, the keyword short form is used. The program message is correct because it utilizes the default nodes of `:FREQ [:CW]` and `:POW [:LEVe1]`. Since default nodes do not affect the current path, it is not necessary to use a leading colon before `FREQ` or `POW`.

File Name Variables

File name variables designate a data file and file path. File name variables are used in the SCPI command syntax whenever files are accessed. The name of the file is always required, but the file path can sometimes be optional or be designated using different formats. The following table shows these different file path formats:

Format	File Name Variable	Example
Format 1	"<file name>"	"Test_Data"
Format 2	"<file name@msus>"	"Test_Data@SEQ"
Format 3	"<msus:file name>"	"SEQ:Test_Data"
Format 4	"</user/directory/file name>"	"/USER/SEQ/Test_Data"

Formats 2–4 offer programming flexibility and are equivalent. Format 1 can only be used with SCPI commands that imply the path name as part of the command syntax. Typically, SCPI load commands that access user-data files do not need to have a file path designated.

See [Table 1-4 on page 14](#) for information on file types and directories.

NOTE The maximum length for a file name is 23 characters, excluding the file path.

Example Using Format 1

```
:CORR:FLAT:LOAD "FLAT_DATA"
```

The preceding example loads user-flatness data from a file called FLAT_DATA located in the USERFLAT directory. No file path is needed as the command syntax implies the directory where the file is located.

Example Using Format 2

```
:MEM:COPY "IQ_DATA@NVWFM", "Test_DATA@WFM1"
```

The preceding example copies a file named IQ_DATA located in the WAVEFORM directory to a file named Test_DATA in volatile waveform memory (WFM1).

Example Using Format 3

```
:MEM:COPY "NVWFM:IQ_DATA", "WFM1:Test_DATA"
```

The preceding example copies a file named IQ_DATA located in the WAVEFORM directory to a file named Test_DATA in volatile waveform memory (WFM1).

Example Using Format 4

```
:MEM:COPY "/USER/WAVEFORM/IQ_DATA", "/USER/BBG1/WAVEFORM/IQ_DATA"
```

The preceding example copies a file named IQ_DATA located in the WAVEFORM directory to a file named IQ_DATA in volatile waveform memory (WFM1).

The following examples show commands, with different formats, that can be used to download a waveform file named Test_Data into the signal generator's volatile waveform memory (WFM1):

Command Syntax Format 3

```
:MEMory:DATA "WFM1:Test_Data", #ABC
```

Command Syntax Format 4

```
:MEMory:DATA "/USER/BBG1/WAVEFORM/Test_Data", #ABC
```

These commands are equivalent. The data block, #ABC, is described as follows:

- # This character indicates the beginning of the data block
- A Number of digits in the byte count B
- B Byte count in C
- C Waveform data

Refer to “:DATA” on page 105 and the *E4428C/38C ESG Signal Generators Programming Guide* for more information on data blocks and downloading waveform data.

File Types and Directory Structure

The signal generator uses a computer directory model structure for file storage. The top level directory is called the USER directory. All other directories are subdirectories located under the USER directory. Each subdirectory is dedicated to the type of data stored. For example, the FIR directory is used to store finite impulse filter (FIR) coefficient data whereas the MARKERS directory is used to store marker data.

The following table lists signal generator the subdirectories and file paths where file types are stored.

Table 1-4 File Types and Directory Structures

File System	File Type	File Path	MSUS Path
BINARY ^a	BIN	/USER/BIN	BINARY: ^b
BIT ^a	BIT	/USER/BIT	BIT:

Table 1-4 File Types and Directory Structures

File System	File Type	File Path	MSUS Path
CDMA ^{ab}	CDMA	/USER/CDMA	CDMA:
DMOD - ARB digital modulation file ^a	DMOD	/USER/DMOD	DMOD:
DWCDMA - ARB downlink W-CDMA file ^a	DWCD	/USER/DWCDMA	DWCDMA:
FCDMA - ARB forward link cdma2000 file ^a	FCDM	/USER/FCDMA	FCDMA:
FIR - finite impulse response filter file	FIR	/USER/FIR	FIR:
FSK - frequency shift keying modulation file ^a	FSK	/USER/FSK	FSK:
HDR1 - volatile arbitrary waveform header file ^a	HDR1	/USER/BBG1/HEADER	HDR1:
I/Q - modulation file ^a	IQ	/USER/IQ	IQ:
LIST - sweep list file	LIST	/USER/LIST	LIST:
MCDMA - ARB multicarrier CDMA file ^a	MCDM	/USER/MCDMA	MCDMA:
MDMOD - ARB multicarrier digital modulation file ^a	MDM	/USER/MDMOD	MDMOD:
MDWCDMA - ARB multicarrier downlink W-CDMA file ^a	MDWC	/USER/MDWCDMA	MDWCDMA:
MFCDMA - ARB multicarrier forward link cdma2000 file ^a	MFCD	/USER/MFCDMA	MFCDMA:
MKR1 - volatile arbitrary waveform marker file ^a	MKR1	/USER/BBG1/MARKERS	MKR1:
MTONE - ARB multitone file ^a	MTON	/USER/MTONE	MTONE:
NVHDR - non-volatile arbitrary waveform header file ^a	NVHDR	/USER/HEADER	NVHDR:
NVMKR - non-volatile arbitrary waveform marker file ^a	NVMKR	/USER/MARKERS	NVMKR:

Table 1-4 File Types and Directory Structures

File System	File Type	File Path	MSUS Path
NVWFM - non-volatile arbitrary waveform file ^a	NVWFM	/USER/WAVEFORM	NVWFM:
RCDMA - ARB reverse link cdma2000 file ^a	RCDM	/USER/RCDM	RCDM:
SEQ - ARB sequence file ^a	SEQ	/USER/SEQ	SEQ:
SHAPE - burst shape file ^a	SHAP	/USER/SHAPE	SHAPE:
STATE	STAT	/USER/STATE	STATE:
USERFLAT - user-flatness file	UFLT	/USER/USERFLAT	USERFLAT:
UWCDMA - ARB uplink W-CDMA file ^a	UWCD	/USER/UWCDMA	UWCDMA:
WFM1 - waveform file ^a	WFM1	/USER/BBG1/WAVEFORM	WFM1:

- a. This feature does not apply to the E4428C.
- b. This msus designator is optional.

MSUS (Mass Storage Unit Specifier) Variable

The variable "<msus>" enables a command to be file type specific when working with user files. Some commands use it as the only command parameter, while others can use it in conjunction with a file name when a command is not file type specific. When used with a file name, it is similar to Format 2 in the "File Name Variables" section on page 13. The difference is the file type specifier (msus) occupies its own variable and is not part of the file name syntax.

The following examples illustrate the usage of the variable "<msus>" when it is the only command parameter:

Command Syntax with the msus variable

```
:MMEMory:CATalog? "<msus>"
```

Command Syntax with the file system

```
:MMEMory:CATalog? "LIST:"
```

The variable "<msus>" is replaced with "LIST:". When the command is executed, the output displays only the files from the List file system.

The following examples illustrate the usage of the variable "<file name>" with the variable "<msus>":

Command Syntax with the file name and msus variables

```
:MMEMory:DELEte[:NAME] "<file name>", ["<msus>"]
```

Command Syntax with the file name and file system

```
:MMEMory:DELEte:NAME "LIST_1", "LIST:"
```

The command from the above example cannot discern which file system LIST_1 belongs to without a file system specifier and will not work without it. When the command is properly executed, LIST_1 is deleted from the List file system.

The following example shows the same command, but using Format 2 from the “File Name Variables” section on [page 13](#):

```
:MMEMory:DELEte:NAME "LIST_1@LIST"
```

When a file name is a parameter for a command that is not file system specific, either format ("`<file name>`", "`<msus>`" or "`<file name@msus>`") will work.

Refer to [Table 1-4 on page 14](#) for a listing of the file systems and types.

Quote Usage with SCPI Commands

As a general rule, programming languages require that SCPI commands be enclosed in double quotes as shown in the following example:

```
":FM:EXTernal:IMPedance 600"
```

However when a string is the parameter for a SCPI command, additional quotes or other delimiters may be required to identify the string. Your programming language may use two sets of double quotes, one set of single quotes, or back slashes with quotes to signify the string parameter. The following examples illustrate these different formats:

```
"MEMory:LOAD:LIST ""myfile"" used in BASIC programming languages
```

```
"MEMory:LOAD:LIST \"myfile\" used in C, C++, Java, and PERL
```

```
"MEMory:LOAD:LIST 'myfile' accepted by most programming languages
```

Consult your programming language reference manual to determine the correct format.

Binary, Decimal, Hexadecimal, and Octal Formats

Command values may be entered using a binary, decimal, hexadecimal, or octal format. When the binary, hexadecimal, or octal format is used, their values must be preceded with the proper identifier. The decimal format (default format) requires no identifier and the signal generator assumes this format when a numeric value is entered without one. The following list shows the identifiers for the formats that require them:

- #B identifies the number as a binary numeric value (base-2).
- #H identifies the number as a hexadecimal alphanumeric value (base-16).
- #Q identifies the number as a octal alphanumeric value (base-8).

The following are examples of SCPI command values and identifiers for the decimal value 45:

#B101101	binary equivalent
#H2D	hexadecimal equivalent
#Q55	octal equivalent

The following example sets the RF output power to 10 dBm (or the equivalent value for the currently selected power unit, such as DBUV or DBUVEMF) using the hexadecimal value 000A:

```
:POW #H000A
```

A unit of measure, such as DBM or mV, will not work with the values when using a format other than decimal.

The following example sets the bluetooth board address to FFBF7 (hexadecimal):

```
:RADio:BLUeTooth:ARB:BDADdr #HFFBF7
```

2 Basic Function Commands

This chapter provides SCPI descriptions for subsystems dedicated to signal generator operations common to most ESG Signal Generators. This chapter contains the following major sections:

- “Correction Subsystem ([:SOURce]:CORRection)” on page 20
- “Digital Modulation Subsystem—E4438C ([:SOURce])” on page 22
- “Frequency Subsystem ([:SOURce])” on page 38
- “List/Sweep Subsystem ([:SOURce])” on page 49
- “Power Subsystem ([:SOURce]:POWer)” on page 58

Correction Subsystem ([:SOURCE]:CORREction)

:FLATness:LOAD

Supported All Models

```
[:SOURCE]:CORREction:FLATness:LOAD "<file name>"
```

This command loads a user-flatness correction file. The "<file name>" variable is the name of the file located in the Catalog of USERFLAT Files. The directory path is implied in the command and need not be specified in the variable name. For more information on file name syntax, refer to [“File Name Variables” on page 13](#).

Key Entry Load From Selected File

:FLATness:PAIR

Supported All Models

```
[:SOURCE]:CORREction:FLATness:PAIR <freq> [<unit>] , <corr> [<unit>]
```

This command sets a frequency and amplitude correction pair.

<corr.> This variable is the power correction.

Range	Frequency	Standard	Option UNB
	Option 501: 100kHz–1GHZ	–136 to 20DB	–136 to 25DB
	Option 502: 100kHz–2GHZ	–136 to 20DB	–136 to 25DB
	Option 503: 100kHz–3GHZ	–136 to 20DB	–136 to 25DB
	Option 504: 100kHz–4GHZ	–136 to 20DB	–136 to 25DB
	Option 506: 100kHz–6GHZ	–136 to 25DB	N/A

Key Entry Configure Cal Array

Remarks The maximum number of points that can be entered is 1601. Options 501, 502, and 504 are specific to the E4438C.

:FLATness:POINTS

Supported All Models

```
[:SOURCE]:CORREction:FLATness:POINTS?
```

This query returns the number of points in the user-flatness correction file.

:FLATness:PRESet

Supported All Models

CAUTION The current correction data will be overwritten once this command is executed. Save the current data if needed. Refer to “:FLATness:STORE” on page 21 for storing user-flatness files.

[:SOURCE]:CORREction:FLATness:PRESet

This command presets the user-flatness correction to a factory-defined setting that consists of one point.

Key Entry Preset List

:FLATness:STORE

Supported All Models

[:SOURCE]:CORREction:FLATness:STORE "<file name>"

This command stores the current user-flatness correction data to a file named by the :CORREction:FLATness:STORE. The directory path is implied in the command and need not be specified in the "<file name>" variable.

Key Entry Store To File

Remarks For information on file name syntax, refer to “File Name Variables” on page 13.

[:STATe]

Supported All Models

[:SOURCE]:CORREction[:STATe] ON|OFF|1|0

[:SOURCE]:CORREction[:STATe]?

This command enables or disables the user-flatness corrections.

***RST** 0

Key Entry Flatness Off On

Digital Modulation Subsystem—E4438C ([:SOURce])

:BURSt:SOURce

Supported E4438C

[[:SOURce]] :BURSt:SOURce EXT [1] | INT [1]

[[:SOURce]] :BURSt:SOURce?

This command selects either an internally generated or an externally supplied burst source.

***RST** EXT

Key Entry Burst Envelope Int Ext Off

Remarks The external burst source is applied to the EXT 1 INPUT connector.
The INT[1] choice will not work unless an internal burst source is active.

:BURSt:STATe

Supported E4438C

[[:SOURce]] :BURSt:STATe ON | OFF | 1 | 0

[[:SOURce]] :BURSt:STATe?

This command enables or disables the burst envelope function.

***RST** 0

Key Entry Burst Envelope Int Ext Off

:DM:EXTeRnal:ALC:BA NDwidth|BWIDth

Supported All Models

NOTE Refer to the *Programming Compatibility Guide* for information on this command. This command was replaced by the “:ALC:BA NDwidth|BWIDth” command shown on [page 58](#) and the “:ALC:BA NDwidth” command on [page 59](#).

:DM:EXTernal:HCRest[:STATe]

Supported E4438C

```
[ :SOURce ] :DM:EXTernal:HCRest [ :STATe ] ON | OFF | 1 | 0  
[ :SOURce ] :DM:EXTernal:HCRest [ :STATe ] ?
```

This command changes the operating condition to accommodate I/Q inputs with a high crest factor.

ON(1) This choice turns high crest mode on for externally applied signals with high crest factors. High crest mode allows the signal generator to process these signals with less distortion. For crest factors higher than 4 dB, I/Q drive levels should be reduced by 1 dB for each dB above that level. In high crest mode, the maximum output level is reduced and power level accuracy is degraded.

OFF(0) This choice disables the high crest mode.

***RST** 0

Key Entry High Crest Mode Off On

:DM:EXTernal:FILTer

Supported E4438C

```
[ :SOURce ] :DM:EXTernal:FILTer 40e6 | THROugh  
[ :SOURce ] :DM:EXTernal:FILTer ?
```

This command selects the filter or through path for I/Q signals routed to the rear panel I and Q outputs. Selecting a filter using this command will automatically set “[:DM:EXTernal:FILTer:AUTO](#)” on [page 23](#) to OFF(0) mode.

40e6 This choice applies a 40 MHz baseband filter.

THROugh This choice bypasses filtering.

***RST** THR

Key Entry 40.000 MHz Through

:DM:EXTernal:FILTer:AUTO

Supported E4438C

```
[ :SOURce ] :DM:EXTernal:FILTer:AUTO ON | OFF | 1 | 0  
[ :SOURce ] :DM:EXTernal:FILTer:AUTO ?
```

This command enables or disables the automatic selection of the filters for I/Q signals routed to the rear panel outputs.

Digital Modulation Subsystem—E4438C ([:SOURce])

- ON(1) This choice will automatically select a digital modulation filter optimized for the current signal generator settings.
- OFF(0) This choice disables the auto feature which lets you select a digital modulation filter or through path. Refer to “:DM:EXTernal:FILTer” on page 23 for selecting a filter or through path.
- *RST 1
- Key Entry I/Q Output Filter Manual Auto**

:DM:EXTernal:POLarity

- Supported** E4438C
- [:SOURce]:DM:EXTernal:POLarity NORMAL|INVERT
- [:SOURce]:DM:EXTernal:POLarity?
- This command sets the phase polarity for the I/Q signal.
- *RST NORM
- Key Entry Int Phase Polarity Normal Invert**
- Remarks** This command is for backward compatibility with the appropriate ESG E44xxB.

:DM:EXTernal:SOURce

- Supported** E4438C
- [:SOURce]:DM:EXTernal:SOURce EXTernal|INTernal|BBG1|EXT600|OFF|SUM
- [:SOURce]:DM:EXTernal:SOURce?
- This command selects the I/Q signal source that is routed to the rear panel I and Q output connectors.
- EXTernal This choice routes a portion of the externally applied signals at the 50 ohm I and Q input connectors to the rear panel I and Q output connectors.
- INTernal This choice is for backward compatibility with the appropriate ESG E44xxB and performs the same function as the BBG1 selection.
- BBG1 This choice routes a portion of the baseband generator I/Q signals to the rear panel I and Q connectors and requires Option 001/601 or 002/602.
- EXT600 This choice routes a portion of the externally applied signals at the 600 ohm I and Q input connectors to the rear panel I and Q output connectors.
- OFF This choice disables the output to the rear panel I and Q output connectors.

SUM	This choice routes a portion of the summed I/Q signals from source one and two, to the rear panel I and Q output connectors. See “:DM:SRATio” on page 36 for setting the summing ratio of the I/Q signals between source one and two.
*RST	EXT
Key Entry	Ext 50 Ohm BBG1 Ext 600 Ohm Off Sum
Remarks	The output is the analog component of the I and Q signals. For selecting the I/Q source, refer to “:DM:SOURce” on page 35.

:DM:IQADjustment:BBG:QSKew

Supported E4438C with Option 001/601or 002/602

```
[ :SOURce ] :DM:IQADjustment:BBG:QSKew <val><unit>
[ :SOURce ] :DM:IQADjustment:BBG:QSKew?
```

This command affects both the rear-panel I and Q signals, and the RF output path by adjusting the phase angle (quadrature skew) of the Q vector.

Positive skew increases the angle from 90 degrees while negative skew decreases the angle from 90 degrees. When the quadrature skew is zero, the phase angle between the I and Q vectors is 90 degrees.

The <val> variable has a minimum resolution of 0.1. The command works with or without the unit variable.

Example

```
:DM:IQAD:BBG:QSK 4.5DEG
```

The preceding example increases the phase angle by 4.5 degrees.

***RST** +0.00000000E+000

Range -30 to 30DEG

Key Entry **Quadrature Angle Adjustment**

Remarks This command is effective only if the state of the I/Q adjustment function is set to ON. Refer to “:DM:IQADjustment[:STATe]” on page 32.

To change the quadrature skew on only the RF output path, see “:DM:IQADjustment:QSKew” on page 30.

:DM:IQADjustment:EXTernal:COFFset**Supported** E4438C

[:SOURce]:DM:IQADjustment:EXTernal:COFFset <val>

[:SOURce]:DM:IQADjustment:EXTernal:COFFset?

This command sets the common mode offset voltage for both the in-phase (I) and quadrature-phase (Q) signals going to the rear panel I and Q output connectors.

The variable <val> is expressed in units of volts (mV–V).

***RST** +0.00000000E+000**Range** –3 to 3**Key Entry** **Common Mode I/Q Offset**

Remarks This command is effective only if the state of the I/Q adjustment function is set to ON. Refer to “:DM:IQADjustment[:STATE]” on page 32.

:DM:IQADjustment:EXTernal:DIOFFset**Supported** E4438C

[:SOURce]:DM:IQADjustment:EXTernal:DIOFFset <val>

[:SOURce]:DM:IQADjustment:EXTernal:DIOFFset?

This command sets the differential offset voltage for an in-phase (I) signal routed to the I output connectors.

The variable <val> is expressed in units of volts (mV–V).

***RST** +0.00000000E+000**Range** –3 to 3**Key Entry** **Diff. Mode I Offset**

Remarks This command is effective only if the state of the I/Q adjustment function is set to ON. Refer to “:DM:IQADjustment[:STATE]” on page 32.

:DM:IQADjustment:EXternal:DQOFFset

Supported E4438C

```
[ :SOURce ] :DM:IQADjustment:EXternal:DQOFFset <val>  
[ :SOURce ] :DM:IQADjustment:EXternal:DQOFFset?
```

This command sets the differential offset voltage for a quadrature-phase (Q) signal routed to the Q output connectors.

***RST** +0.00000000E+000

Range -4 to 4

Key Entry **Diff. Mode Q Offset**

Remarks This command is effective only if the state of the I/Q adjustment function is set to ON. Refer to “:DM:IQADjustment[:STATE]” on page 32.

:DM:IQADjustment:EXternal:GAIN

Supported E4438C

```
[ :SOURce ] :DM:IQADjustment:EXternal:GAIN <val>  
[ :SOURce ] :DM:IQADjustment:EXternal:GAIN?
```

This command sets the I/Q gain ratio for signals routed to the rear panel I and Q output connectors.

The variable <val> is expressed in units of decibels (dB).

***RST** +0.00000000E+000

Range -4 to 4

Key Entry **I/Q Out Gain Balance**

Remarks This command is effective only if the state of the I/Q adjustment function is set to ON. Refer to “:DM:IQADjustment[:STATE]” on page 32.

:DM:IQADjustment:EXternal:IOFFset

Supported E4438C

```
[ :SOURce ] :DM:IQADjustment:EXternal:IOFFset <val>  
[ :SOURce ] :DM:IQADjustment:EXternal:IOFFset?
```

Digital Modulation Subsystem—E4438C (:SOURce)

This command sets the offset voltage for a signal applied to the 600 ohm I input connector.

The variable <val> is expressed in units of volts (mV–V).

***RST** +0.00000000E+000

Key Entry **Ext In 600 Ohm I Offset**

Range –5 to 5

Remarks This command is effective only if the state of the I/Q adjustment function is set to ON. Refer to “:DM:IQADjustment[:STATE]” on page 32.

:DM:IQADjustment:EXTernal:IQATten

Supported E4438C

[:SOURce] :DM:IQADjustment:EXTernal:IQATten <val>

[:SOURce] :DM:IQADjustment:EXTernal:IQATten?

This command sets the I/Q output attenuation level.

The variable <val> is expressed in units of decibels (dB).

***RST** +6.00000000E+000

Range 0–40

Key Entry **I/Q Output Atten**

Remarks The value set by this command is active even if the I/Q adjustment function is off.

:DM:IQADjustment:EXTernal:QOFFset

Supported E4438C

[:SOURce] :DM:IQADjustment:EXTernal:QOFFset <val>

[:SOURce] :DM:IQADjustment:EXTernal:QOFFset?

This command sets the offset voltage for a signal applied to the 600 ohm Q input connector.

The variable <val> is expressed in units of volts (mV–V).

***RST** +0.00000000E+000

Range –5 to 5

Key Entry **Ext In 600 Ohm Q Offset**

Remarks This command is effective only if the state of the I/Q adjustment function is set to ON. Refer to “:DM:IQADjustment[:STATE]” on page 32.

:DM:IQADjustment:GAIN

Supported E4438C

[:SOURce] :DM:IQADjustment:GAIN <val>

[:SOURce] :DM:IQADjustment:GAIN?

This command sets the gain for the I signal relative to the Q signal.

The variable <val> is expressed in units of decibels (dB).

***RST** +0.00000000E+000

Range -4 to 4

Key Entry **I/Q Gain Balance Source 1**

Remarks This command is effective only if the state of the I/Q adjustment function is set to ON. Refer to “:DM:IQADjustment[:STAtE]” on page 32.

:DM:IQADjustment:IOFFset

Supported E4438C

[:SOURce] :DM:IQADjustment:IOFFset <val>

[:SOURce] :DM:IQADjustment:IOFFset?

This command adjusts the I channel offset value.

The variable <val> is expressed in units of percent with a minimum resolution of 0.025.

***RST** +0.00000000E+000

Range -50.000 to 50.000

Key Entry **I Offset**

Remarks When using this command to minimize the LO feedthrough signal, optimum performance is achieved when the command is sent after all other I/Q path commands are executed, such as those that change the internal phase polarity or adjust the modulator attenuator. If other adjustments are made after minimizing is performed, the LO feedthrough signal may increase.

This command is effective only if the state of the I/Q adjustment function is set to ON. Refer to “:DM:IQADjustment[:STAtE]” on page 32.

:DM:IQADjustment:QOFFset**Supported** E4438C

[:SOURce]:DM:IQADjustment:QOFFset

[:SOURce]:DM:IQADjustment:QOFFset?

This command adjusts the Q channel offset value.

The variable <val> is expressed in units of percent with a minimum resolution of 0.025.

***RST** +0.00000000E+000**Range** -50.000 to 50.000**Key Entry** Q Offset

Remarks When using this command to minimize the LO feedthrough signal, optimum performance is achieved when the command is sent after all other I/Q path commands are executed, such as those that change the internal phase polarity or adjust the modulator attenuator. If other adjustments are made after minimizing is performed, the LO feedthrough signal may increase.

This command is effective only if the state of the I/Q adjustment function is set to ON. Refer to “:DM:IQADjustment[:STATe]” on page 32.

:DM:IQADjustment:QSKew**Supported** E4438C

[:SOURce]:DM:IQADjustment:QSKew <val>

[:SOURce]:DM:IQADjustment:QSKew?

This command adjusts the phase angle (quadrature skew) between the I and Q vectors by increasing or decreasing the Q phase angle. It affects only the RF output path.

If the signal generator is operating at frequencies greater than 3.3 GHz, quadrature skew settings greater than ± 5 degrees will not be within specifications.

Positive skew increases the angle from 90 degrees while negative skew decreases the angle from 90 degrees. When the quadrature skew is zero, the phase angle between the I and Q vectors is 90 degrees.

The <val> variable is expressed in degrees with a minimum resolution of 0.1.

Example

:DM:IQAD:QSK 4.5

The preceding example increases the phase angle by 4.5 degrees.

*RST	+0.00000000E+000
Range	-1E1 to +1E1
Key Entry	Quadrature Angle Adjustment
Remarks	This command is effective only if the state of the I/Q adjustment function is set to ON. Refer to “:DM:IQADjustment[:STATE]” on page 32. To change the quadrature skew for both the rear-panel I and Q signals, and RF output path, see “:DM:IQADjustment:BBG:QSKew” on page 25 (requires Option 001/601 or 002/602).

:DM:IQADjustment:SKEW

Supported E4438C

```
[ :SOURce ] :DM:IQADjustment :SKEW [ :DELay ] <val>  
[ :SOURce ] :DM:IQADjustment :SKEW?
```

This command changes the input skew which is a time delay difference between the I and Q signals. Equal and opposite skew is applied to both I and Q and affects the RF Output and I/Q output paths simultaneously. A positive value delays the I signal relative to the Q signal, and a negative value delays the Q signal relative to the I signal.

If the internal I/Q correction path is set to RF or BB the I/Q signals are already optimized and adjusting I/Q skew would add an impairment to the signals. If the internal I/Q correction path is set to Off, then adjusting the I/Q skew could improve the I/Q signals. The I/Q skew adjustment cannot be performed on the MSK, FSK, and C4FM constant envelope modulations.

I/Q skew adjustments are preserved when the instrument state is saved. I/Q skew adjustments are also preserved when instrument settings are changed. If the signal generator is calibrated, the skew adjustments are added to the calibration value used for the given signal generator state. If the signal generator is uncalibrated, the skew adjustments are re-applied directly.

Using I/Q skew while playing a user FIR file greater than 32 symbols will generate an error.

The variable <val> is expressed in seconds. Range limits are determined by the modulation configuration but is limited to a maximum of ± 2 seconds.

Example

```
:DM:IQAD:SKEW .5
```

The preceding example sets the time delay difference between the I and Q signals to 500 milliseconds.

*RST	+0.00000000E+000
-------------	------------------

Key Entry	I/Q Timing Skew
------------------	------------------------

:DM:IQADjustment:SKEW:Path**Supported** E4438C

```
[:SOURce]:DM:IQADjustment:SKEW:PATH RF BB
[:SOURce]:DM:IQADjustment:SKEW?
```

This command selects either the RF or BB (baseband) path as the path to which skew timing corrections will be applied. If there are no factory I/Q timing skew corrections data, then adjusting the I/Q timing skew for the selected path may improve the error vector magnitude (EVM) of the signal. Refer to the “[:DM:IQADjustment:SKEW](#)” on page 31 for more information.

If internal I/Q corrections are available for the RF or external I/Q output (BB) path then the I/Q signals are already optimized and adjusting I/Q skew for either path would add an impairment to the signal.

Example

```
:DM:IQAD:SKEW:PATH RF
```

The preceding example selects the RF path as the path to which skew timing adjustments will be made.

```
*RST +0.00000000E+000
```

Key Entry I/Q Timing Skew Path

:DM:IQADjustment[:STATe]**Supported** E4438C

```
[:SOURce]:DM:IQADjustment[:STATe] ON|OFF|1|0
[:SOURce]:DM:IQADjustment[:STATe]?
```

This command enables or disables the I/Q adjustments.

Example

```
:DM:IQAD 1
```

The preceding example enables I/Q adjustments.

```
*RST 0
```

Key Entry I/Q Adjustments Off On

:DM:MODulation:FILTer**Supported** E4438C

```
[:SOURce]:DM:MODulation:FILTer 2.1e6|40e6|THROUGH
[:SOURce]:DM:MODulation:FILTer?
```

This command enables you to select a filter or through path for I/Q signals modulated onto the RF carrier. Selecting a filter with this command automatically sets “:DM:MODulation:FILTer:AUTO” to OFF(0).

2.1E6 This choice applies a 2.1 MHz baseband filter to the I/Q signals.

40E6 This choice applies a 40 MHz baseband filter to the I/Q signals.

THRough This choice bypasses filtering.

***RST** THR

Key Entry **2.100 MHz 40.000 MHz Through**

:DM:MODulation:FILTer:AUTO

Supported E4438C

[:SOURce] :DM:MODulation:FILTer:AUTO ON | OFF | 1 | 0

[:SOURce] :DM:MODulation:FILTer:AUTO?

This command enables or disables the automatic selection of the filters for I/Q signals modulated onto the RF carrier.

ON(1) This choice will automatically select a digital modulation filter.

OFF(0) This choice disables the auto feature which lets you select a digital modulation filter or through path. Refer to “:DM:MODulation:FILTer” on page 32 for selecting a filter or through path.

***RST** 1

Key Entry **I/Q Mod Filter Manual Auto**

:DM:MODulation:ATTen

Supported E4438C

[:SOURce] :DM:MODulation:ATTen <val>

[:SOURce] :DM:MODulation:ATTen?

This command attenuates the I/Q signals being modulated through the signal generator RF path.

The variable <val> is expressed in units of decibels (dB).

***RST** +2.00000000E+000

Range 0–40

Key Entry **Modulator Atten Manual Auto**

:DM:MODulation:ATTen:AUTO**Supported** E4438C

[:SOURce]:DM:MODulation:ATTen:AUTO ON|OFF|1|0

[:SOURce]:DM:MODulation:ATTen:AUTO?

This command enables or disables the I/Q attenuation auto mode.

ON (1) This choice enables the attenuation auto mode which optimizes the modulator attenuation for the current conditions.

OFF (0) This choice holds the attenuator at its current setting or at a selected value. Refer to “:DM:MODulation:ATTen” on page 33 for setting the attenuation value.

RST** 1**Key Entry** Modulator Atten Manual Auto**:DM:POLarity[:ALL]*Supported** E4438C

[:SOURce]:DM:POLarity[:ALL] NORMal|INVert

[:SOURce]:DM:POLarity?

This command sets the digital modulation phase polarity.

NORMal This choice selects normal phase polarity for the I and Q signals.

INVert This choice flips the I and Q signals by routing the I signal to the Q input of the I/Q modulator and the Q signal to the I input.

***RST** NORM**Key Entry** Int Phase Polarity Normal Invert

:DM:SKEW:PATH

Supported E4438C

[:SOURce] :DM:SKEW:PATH RF|BB

[:SOURce] :DM:SKEW:PATH?

This command selects the skew path.

RF When RF is selected, the skew is optimized for the I/Q signal applied to the RF Output. The BB output will be functional, but the I/Q timing skew applied will be optimized for the RF path. When using this choice, seven symbols of latency are added to the Arb based waveform. While in real-time mode, the maximum number of user symbols for the FIR is limited to 32.

BB When BB is selected, the skew is optimized for the I/Q signal outputs on the rear panel. The RF Output will be functional, but the I/Q timing skew applied will be optimized for the BB path. When using this choice, seven symbols of latency are added to the Arb based waveform. While in real-time mode, the maximum number of user symbols for the FIR is limited to 32.

***RST** INT

Key Entry Int I/Q Skew Corrections RF BB Off

:DM:SKEW[:STATe]

Supported E4438C

[:SOURce] :DM:SKEW[:STATe] ON|OFF|1|0

[:SOURce] :DM:SKEW[:STATe] ?

This command enables or disables the I/Q timing skew correction function.

***RST** 1

Key Entry Int I/Q Skew Corrections RF BB Off

:DM:SOURce

Supported E4438C

[:SOURce] :DM:SOURce [1] | 2 EXTernal | INTernal | BBG1 | EXT600 | OFF

[:SOURce] :DM:SOURce?

This command selects the I/Q modulator source.

EXTernal This choice selects a 50 ohm impedance for the I and Q input connectors and routes the applied signals to the I/Q modulator.

Basic Function Commands

Digital Modulation Subsystem—E4438C ([:SOURce])

INTernal	This choice is for backward compatibility with the appropriate ESG E44xxB and performs the same function as the BBG1 selection.
BBG1	This choice selects the baseband generator as the source for the I/Q modulator and requires Option 001/601 or 002/602.
EXT600	This choice selects a 600 ohm impedance for the I and Q input connectors and routes the applied signals to the I/Q modulator.
OFF	This choice disables the digital modulation source.
*RST	EXT
Key Entry	Ext 50 Ohm BBG1 Ext 600 Ohm Off

:DM:SRATio

Supported E4438C

[[:SOURce]:DM:SRATio <val><unit>

[[:SOURce]:DM:SRATio?

This command sets the power level difference (ratio) between the source one and source two signals when the two signals are summed together. A positive ratio value reduces the amplitude for source two, while a negative ratio value reduces the amplitude for source one.

The range for the summing ratio is dependent on the modulator attenuator (mod atten) setting for the signal generator that is summing the signals together. The minimum range is achieved when the modulator attenuator setting is zero and the maximum range is reached when the maximum attenuator value is used. The range can be calculated using the following formula:

$\pm \text{Range} = 50 \text{ dB} + \text{Mod Atten}$

***RST** +0.00000000E+000

Range *Min:* $\pm 50 \text{ dB}$ *Max:* $\pm 90 \text{ dB}$

Key Entry **Summing Ratio (SRC1/SRC2) x.xx dB**

Remarks For real-time modulation format modulator attenuator settings, see [“:DM:MODulation:ATTen” on page 33](#) and [“:DM:MODulation:ATTen:AUTO” on page 34](#). For an Arb modulation format modulator attenuator setting, refer to the SCPI command subsystem for the Arb format being used and find the commands that contain the command mnemonics IQ:MODulation:ATTen.

:DM:STATe

Supported E4438C

[:SOURce] :DM:STATe ON|OFF|1|0

[:SOURce] :DM:STATe?

This command enables or disables the I/Q modulator.

ON (1) This choice enables the internal I/Q modulator.

OFF (0) This choice disables the internal I/Q modulator. You can turn off the I/Q modulation with this choice even though a digital modulation format is enabled. With this configuration, the RF output signal will not be modulated, but the I/Q signals may be present at the rear panel I and Q outputs depending on the rear panel output selection.

***RST** 0

Key Entry I/Q Off On

Remarks The I/Q modulator is enabled whenever a digital format is turned on. The I/Q annunciator will be shown on the signal generator display whenever the I/Q modulator is on.

Frequency Subsystem ([:SOURCE])

:FREQUENCY:CHANNELS:BAND

Supported All Models

```
[:SOURCE]:FREQUENCY:CHANNELS:BAND NBASe|NMOBILE|BPGSm|MPGSm|BEGSm|MEGSm|
BRGSm|MRGSm|BDCS|MDCS|BPCS|MPCS|B450|GM450|B480|M480|B850|M850|B8|M8|B15
|M15|B390|B420|B460|B915|M380|M410|M450|M870|PHS|DECT
[:SOURCE]:FREQUENCY:CHANNELS:BAND?
```

This command sets the frequency of the signal generator by specifying a frequency channel band.

NBASe	This choice selects Standard Base as the frequency band for NADC.
NMOBILE	This choice selects Standard Mobile as the frequency band for NADC.
BPGSm	This choice selects P-Gsm 900 Base as the frequency band for GSM.
MPGSm	This choice selects P-Gsm 900 Mobile as the frequency band for GSM.
BEGSm	This choice selects E-Gsm 900 Base as the frequency band for GSM.
MEGSm	This choice selects E-Gsm 900 Mobile as the frequency band for GSM.
BRGSm	This choice selects R-Gsm 900 Base as the frequency band for GSM.
MRGSm	This choice selects R-Gsm 900 Mobile as the frequency band for GSM.
BDCS	This choice selects DCS 1800 Base as the frequency band for GSM.
MDCS	This choice selects DCS 1800 Mobile as the frequency band for GSM.
BPCS	This choice selects PCS 1900 Base as the frequency band for GSM.
MPCS	This choice selects PCS 1900 Mobile as the frequency band for GSM.
B450	This choice selects Gsm 450 Base as the frequency band for GSM.
GM450	This choice selects Gsm 450 Mobile as the frequency band for GSM.
B480	This choice selects Gsm 480 Base as the frequency band for GSM.
M480	This choice selects Gsm 480 Mobile as the frequency band for GSM.
B850	This choice selects Gsm 850 Base as the frequency band for GSM.
M850	This choice selects Gsm 850 Mobile as the frequency band for GSM.
B8	This choice selects 800MHz Base as the frequency band for PDC.

M8	This choice selects 800MHz Mobile as the frequency band for PDC.
B15	This choice selects 1500MHz Base as the frequency band for PDC.
M15	This choice selects 1500MHz Mobile as the frequency band for PDC.
B390	This choice selects Base 390-400 as the frequency band for TETRA.
B420	This choice selects Base 420-430 as the frequency band for TETRA.
B460	This choice selects Base 460-470 as the frequency band for TETRA.
B915	This choice selects Base 915-921 as the frequency band for TETRA.
M380	This choice selects Mobile 380-390 as the frequency band for TETRA.
M410	This choice selects Mobile 410-420 as the frequency band for TETRA.
M450	This choice selects Mobile 450-460 as the frequency band for TETRA.
M870	This choice selects Mobile 870-876 as the frequency band for TETRA.
PHS	This choice selects Standard PHS as the frequency band.
DECT	This choice selects Standard DECT as the frequency band.

***RST**

BPGS

Key Entry

P-GSM Base E-GSM Base R-GSM Base DCS Base
PCS Base GSM 450 Base GSM 480 Base GSM 850 Base
NADC Base 800MHZ Base 1500MHZ Base
Tetra Base 390/400 Tetra Base 420/430 Tetra Base 460/470
Tetra Base 915/921 PHS Standard DECT Standard
P-GSM Mobile E-GSM Mobile R-GSM Mobile DCS Mobile
PCS Mobile GSM 450 Mobile GSM 480 Mobile GSM 850 Mobile
NADC Mobile 800MHZ Mobile 1500MHZ Mobile
Tetra Mobile 380/390 Tetra Mobile 410/420 Tetra Mobile 450/460
Tetra Mobile 870/876

Remarks

The frequency channel state must be enabled for this command to work. Refer to “:FREQUENCY:CHANnels[:STATE]” on page 41.

Frequency Subsystem ([:SOURCE])

:FREQuency:CHANnels:NUMBer

Supported All Models

[:SOURCE] :FREQuency:CHANnels:NUMBer <number>

[:SOURCE] :FREQuency:CHANnels:NUMBer?

This command sets the frequency of the signal generator by specifying a channel number of a given frequency band.

***RST** +1

Range	P-GSM Base/Mobile:	1–24
	E-GSM and R-GSM Base/Mobile:	1–1023
	DCS Base/Mobile:	512–885
	PCS Base/Mobile:	512–900
	GSM-450 Base/Mobile:	259–293
	GSM-480 Base/Mobile:	306–340
	GSM-850 Base/Mobile:	128–251
	NADC Base/Mobile:	1–1023
	800MHZ Base/Mobile:	0–640
	1500MHZ Base/Mobile:	0–960
	TETRA 380/390 Mobile:	3600–4000
	TETRA 390/4000 Base:	3600–4000
	TETRA 410/420 Mobile:	800–1200
	TETRA 420/430 Base:	800–1200
	TETRA 460/470: 2400 through 2800	2400–2800
	TETRA 870/876 Mobile:	600–640
	TETRA 915/921 Base:	600–940
	PHS Standard:	1–255
	DECT Standard:	0–9

Key Entry Channel Number

Remarks The frequency channel state must be enabled for this command to work. Refer to “:FREQuency:CHANnels[:STATE]” on page 41.

:FREQuency:CHANnels[:STATe]

Supported All Models

```
[ :SOURce ] :FREQuency:CHANnels [ :STATe ] ON | OFF | 1 | 0
[ :SOURce ] :FREQuency:CHANnels [ :STATe ] ?
```

This command enables or disables the frequency channel and band selection to set the output frequency.

***RST** 0

Key Entry **Freq Channels Off On**

Remarks To set frequency channels band refer to “:FREQuency:CHANnels:BAND” on [page 38](#).

:FREQuency:FIXed

Supported All Models

```
[ :SOURce ] :FREQuency:FIXed <val><unit> | UP | DOWN
[ :SOURce ] :FREQuency:FIXed?
```

This command sets the signal generator output frequency, or increments or decrements the current RF frequency setting.

<val> A frequency value.

UP Increases the current frequency setting by the value set with the “:FREQuency[:CW]:STEP[:INCRement]” command found on [page 47](#). The front-panel up-arrow key performs the same function.

DOWN Decreases the current frequency setting by the value set with the “:FREQuency[:CW]:STEP[:INCRement]” command found on [page 47](#). The front-panel down-arrow key performs the same function.

***RST** Option 501: +10000000000000E+09
 Option 502: +20000000000000E+09
 Option 503: +30000000000000E+09
 Option 504: +40000000000000E+09
 Option 506: +60000000000000E+09

Range E4438C Option 501: 100kHz–1GHZ
 E4438C Option 502: 100kHz–2GHZ
 Option 503: 100kHz–3GHZ
 E4438C Option 504: 100kHz–4GHZ

Frequency Subsystem (:SOURCE)

Remarks Option 506: 100kHz–6GHz
 To set the frequency mode to FIXed, refer to “:FREQuency:MODE” on page 42.
 A frequency change may affect the current output power. Refer to
 “[:LEVel][:IMMediate][:AMPLitude]” on page 69 for the correct specified
 frequency and amplitude settings.

:FREQuency:MODE

Supported All Models

```
[ :SOURCE ] :FREQuency:MODE CW | FIXed | LIST
[ :SOURCE ] :FREQuency:MODE?
```

This command sets the frequency mode of the signal generator to CW or swept.

CW and FIXed These choices are synonymous with one another and stops a frequency sweep, allowing the ESG to operate at a set frequency. Refer to “:FREQuency[:CW]” on page 46 for setting the frequency in the CW mode and to “:FREQuency:FIXed” on page 41 for setting the frequency in the FIXed mode.

LIST This choice selects the swept frequency mode. If sweep triggering is set to immediate along with continuous sweep mode, executing the command starts the LIST or STEP frequency sweep.

NOTE To perform a frequency and amplitude sweep, you must also select LIST as the power mode. See “:MODE” on page 66 for selecting the list mode for an amplitude sweep.

***RST** CW

Key Entry **Frequency Freq Off**

:FREQuency:MULTiplier

Supported All Models

```
[ :SOURCE ] :FREQuency:MULTiplier <val>
[ :SOURCE ] :FREQuency:MULTiplier?
```

This command sets the multiplier for the signal generator carrier frequency.

***RST** +1.00000000E+000

Range Negative Values: –100 to –.001 Positive Values: .001–1000

Key Entry **Freq Multiplier**

Remarks For any multiplier other than one, the MULT indicator is shown in the frequency area of the display.

:FREQuency:OFFSet

Supported All Models

[[:SOURce]]:FREQuency:OFFSet <val><unit>

[[:SOURce]]:FREQuency:OFFSet?

This command sets the frequency offset.

The query of this command returns a value equal to the original output frequency times the multiplier value, plus the frequency offset value.

***RST** +0.00000000000000E+00

Range -200GHZ to 200GHZ

Key Entry **Freq Offset**

Remarks When an offset has been entered, the OFFS indicator is turned on in the frequency area of the display.

The frequency offset state is turned on when any non-zero value is entered; entering zero will turn it off. Refer to “[:FREQuency:OFFSet:STATe]” for setting the offset state independent of entering offset values.

:FREQuency:OFFSet:STATe

Supported All Models

[[:SOURce]]:FREQuency:OFFSet:STATe ON|OFF|1|0

[[:SOURce]]:FREQuency:OFFSet:STATe?

This command enables or disables the offset frequency.

***RST** 0

Key Entry **Freq Offset**

Remarks Entering OFF (0) will set the frequency offset to 0 Hz.

:FREQuency:REFerence

Supported All Models

[[:SOURce]]:FREQuency:REFerence <val><unit>

[[:SOURce]]:FREQuency:REFerence?

This command sets the output reference frequency.

Basic Function Commands

Frequency Subsystem ([:SOURce])

*RST	+0.00000000000000E+00
Range	Option 501: 0HZ–1GHZ Option 502: 0HZ–2GHZ Option 503: 0HZ–3GHZ Option 504: 0HZ–4GHZ Option 506: 0HZ–6GHZ
Key Entry	Freq Ref Set
Remarks	Options 501, 502, and 504 are specific to the E4438C.

:FREQuency:REFErence:STATe

Supported All Models

```
[ :SOURce ] :FREQuency:REFErence:STATe ON | OFF | 1 | 0  
[ :SOURce ] :FREQuency:REFErence:STATe?
```

This command enables or disables the frequency reference mode.

***RST** 0

Key Entry **Freq Ref Off On**

Remarks When the frequency reference mode is on, subsequent frequency parameters are set relative to the reference value.

:FREQuency:STARt

Supported All Models

```
[ :SOURce ] :FREQuency:STARt <val><unit>  
[ :SOURce ] :FREQuency:STARt?
```

This command sets the first frequency point in a step sweep.

***RST** Option 501: +10000000000000E+09
Option 502: +20000000000000E+09
Option 503: +30000000000000E+09
Option 504: +40000000000000E+09
Option 506: +60000000000000E+09

Range Option 501: 100kHz–1GHZ
Option 502: 100kHz–2GHZ
Option 503: 100kHz–3GHZ

	Option 504: 100kHz–4GHz
	Option 506: 100kHz–6GHz
Key Entry	Freq Start
Remarks	Options 501, 502, and 504 are specific to the E4438C.

:FREQuency:STOP

Supported	All Models
	<code>[:SOURCE]:FREQuency:STOP <val><unit></code> <code>[:SOURCE]:FREQuency:STOP?</code>
	This command sets the last frequency point in a step sweep.
*RST	Option 501: +10000000000000E+09 Option 502: +20000000000000E+09 Option 503: +30000000000000E+09 Option 504: +40000000000000E+09 Option 506: +60000000000000E+09
Range	Option 501: 100kHz–1GHz Option 502: 100kHz–2GHz Option 503: 100kHz–3GHz Option 504: 100kHz–4GHz Option 506: 100kHz–6GHz
Key Entry	Freq Stop
Remarks	Options 501, 502, and 504 are specific to the E4438C.

:FREQuency:SYNThesis

Supported	E4438C except with Option UNJ
	<code>[:SOURCE]:FREQuency:SYNThesis 1 2</code> <code>[:SOURCE]:FREQuency:SYNThesis?</code>
	This command sets the phase-lock loop (PLL) bandwidth to optimize phase noise for offsets above and below 10 kHz.
1	This choice will select mode 1 which optimize phase noise at offsets below 10 kHz.
2	This choice will select mode 2 which optimizes phase noise at offsets above

Basic Function Commands

Frequency Subsystem ([:SOURce])

10 kHz.

***RST** +1

Key Entry **Mode 1 Optimize <10kHz Offset** **Mode 2 Optimize >10kHz Offset**

:FREQuency[:CW]

Supported All Models

[[:SOURce]:FREQuency[:CW] <val><unit>|UP|DOWN

[[:SOURce]:FREQuency[:CW] ?

This command sets the signal generator output frequency for the CW frequency mode, or increments or decrements the current RF frequency setting.

<val> A frequency value.

UP Increases the current frequency setting by the value set with the “:FREQuency[:CW]:STEP[:INCRement]” command found on [page 47](#). The front-panel up-arrow key performs the same function.

DOWN Decreases the current frequency setting by the value set with the “:FREQuency[:CW]:STEP[:INCRement]” command found on [page 47](#). The front-panel down-arrow key performs the same function.

***RST** Option 501: +10000000000000E+09
Option 502: +20000000000000E+09
Option 503: +30000000000000E+09
Option 504: +40000000000000E+09
Option 506: +60000000000000E+09

Range E4438C Option 501: 100kHz–1GHZ
E4438C Option 502: 100kHz–2GHZ
Option 503: 100kHz–3GHZ
E4438C Option 504: 100kHz–4GHZ
Option 506: 100kHz–6GHZ

Key Entry **Frequency**

Remarks To set the frequency mode to CW, refer to “:FREQuency:MODE” on [page 42](#).

A frequency change may affect the current output power. Refer to “[:LEVel][:IMMediate][:AMPLitude]” on [page 69](#) for the correct specified frequency and amplitude settings.

:FREQuency[:CW]:STEP[:INCRement]

Supported All Models

```
[ :SOURce ] :FREQuency [ :CW ] :STEP [ : INCRement ] <val><unit>  
[ :SOURce ] :FREQuency [ :CW ] :STEP [ : INCRement ] ?
```

This command sets the incremental step value for the frequency parameter.

Range .01 Hz–99 GHz

Key Entry **Incr Set**

Remarks The value set with this command is not affected by *RST or a power cycle.

:PHASe:REFerence

Supported All Models

```
[ :SOURce ] :PHASe :REFerence
```

This command sets the current output phase as a zero reference.

Key Entry **Phase Ref Set**

Remarks Subsequent phase adjustments are set relative to the new reference.

:PHASe[:ADJust]

Supported All Models

```
[ :SOURce ] :PHASe [ :ADJust ] <val><unit>  
[ :SOURce ] :PHASe [ :ADJust ] ?
```

This command adjusts the phase of the modulating signal.

The query will only return values in radians.

***RST** +0.00000000E+000

Range Radians: –3.14 to 3.14RAD Degrees: –180 to 179DEG

Key Entry **Adjust Phase**

:ROSCillator:SOURce

Supported All Models

```
[ :SOURce ] :ROSCillator :SOURce ?
```

This command queries the source of the reference oscillator. It returns either INT (internal) or EXT (external).

:ROSCillator:SOURce:AUTO

Supported All Models except signal generators with Option UNJ

`[:SOURce]:ROSCillator:SOURce:AUTO ON|OFF|1|0`

`[:SOURce]:ROSCillator:SOURce:AUTO?`

This command enables or disables the ability of the signal generator to automatically select between the internal and an external reference oscillator.

ON (1) This choice enables the signal generator to detect when a valid reference signal is present at the 10 MHz IN connector and automatically switches from internal to external frequency reference.

OFF (0) This choice selects the internal reference oscillator and disables the switching capability between the internal and an external frequency reference.

***RST** 1

Key Entry **Ref Oscillator Source Auto Off On**

List/Sweep Subsystem ([:SOURce])

A complete sweep setup requires commands from other subsystems. Table 2-1 shows the function and location of these other commands.

Table 2-1 Location of Commands from the other Subsystems

Sweep Type	Function	Command Location	Key Entry under Sweep/List key
List and Step	Start/stop frequency sweep	“:FREQuency:MODE” on page 42	Freq Off
	Start/stop amplitude sweep	“:MODE” on page 66	Ampl Off
	Start/stop frequency and amplitude sweep ¹	“:MODE” on page 66 “:FREQuency:MODE” on page 42	Freq & Ampl Off
	Set up and control sweep triggering ²	“Trigger Subsystem” on page 166	See the “Trigger Subsystem”
List	Load a list sweep file	“:LOAD:LIST” on page 123 and page 127	Load From Selected File
	Store list sweep data to a file	“:STORE:LIST” on page 123 and page 127	Store To File
Step	Start frequency sweep	“:FREQuency:START” on page 44	Freq Start
	Store list sweep data to a file	“:STORE:LIST” on page 123 and page 127	Store To File
	Start amplitude sweep	“:START” on page 67	Ampl Start
	Stop amplitude sweep	“:STOP” on page 68	Ampl Stop

1. Execute both commands to start or stop a frequency and amplitude sweep.
2. For point to point triggering, see “:LIST:TRIGger:SOURce” on page 54.

:LIST:DIRection**Supported** All Models

[:SOURce]:LIST:DIRection UP|DOWN

[:SOURce]:LIST:DIRection?

This command sets the direction of a list or step sweep.

UP This choice enables a sweep in an ascending order:

- first to last point for a list sweep
- start to stop for a step sweep

DOWN This choice reverses the direction of the sweep.

RST** UP**Key Entry** Sweep Direction Down Up**:LIST:DWELl*Supported** All Models

[:SOURce]:LIST:DWELl <val>{, <val>}

[:SOURce]:LIST:DWELl?

This command sets the dwell time for the current list sweep points.

The variable <val> is expressed in units of seconds with a 0.001 resolution.

NOTE The dwell time (<val>) does not begin until the signal generator has settled for the current frequency and/or amplitude change.

Range 0.001–60**Remarks** Dwell time is used when IMMEDIATE is the trigger source. Refer to “:LIST:TRIGger:SOURce” on page 54 for the trigger setting.

The dwell time is the amount of time the sweep is guaranteed to pause after setting the frequency and/or power for the current point.

The setting enabled by this command is not affected by signal generator power-on, preset, or *RST.

:LIST:DWEL:POINTs

Supported All Models

[[:SOURCE]:LIST:DWEL:POINTs?

This command queries the signal generator for the number of dwell points in the current list sweep file.

:LIST:DWEL:TYPE

Supported All Models

[[:SOURCE]:LIST:DWEL:TYPE LIST|STEP

[[:SOURCE]:LIST:DWEL:TYPE?

This command toggles the dwell time for the list sweep points between the values defined in the list sweep and the value for the step sweep.

LIST This choice selects the dwell times from the list sweep. Refer to [“:LIST:DWEL” on page 50](#) for setting the list dwell points.

STEP This choice selects the dwell time from the step sweep. Refer to [“:SWEep:DWEL” on page 56](#) for setting the step dwell.

***RST** LIST

Key Entry Dwell Type List Step

:LIST:FREQuency

Supported All Models

[[:SOURCE]:LIST:FREQuency <val>{,<val>}

[[:SOURCE]:LIST:FREQuency?

This command sets the frequency values for the current list sweep points.

The variable <val> is expressed in units of Hertz.

Range Option 501: 100E3–1E9

Option 502: 100E3–2E9

Option 503: 100E3–3E9

Option 504: 100E3–4E9

Option 506: 100E3–6E9

List/Sweep Subsystem ([:SOURce])

Remarks The setting enabled by this command is not affected by signal generator power-on, preset, or *RST. Options 501, 502, and 504 are specific to the E4438C. The maximum number of list sweep points is 1,601.

:LIST:FREQuency:POINts

Supported All Models

[:SOURce] :LIST:FREQuency:POINts?

This command queries the current list sweep file for the number of frequency points.

:LIST:MANual

Supported All Models

[:SOURce] :LIST:MANual <val>

[:SOURce] :LIST:MANual?

This command sets a list or step sweep point as the current sweep point controlling the frequency and power output.

Range List Sweep: 1–1601 Step Sweep: 2-65535

Key Entry Manual Point

Remarks If list or step mode is controlling frequency or power, or both, then the indexed point in the respective list(s) will be used.

Entering a value with this command will have no effect, unless MANual is the selected mode. Refer to “:LIST:MODE” on page 53 for setting the proper mode.

If the point selected is beyond the length of the longest enabled list, then the point will be set to the maximum possible point, and an error will be generated.

:LIST:MODE

Supported All Models

[:SOURce] :LIST:MODE AUTO|MANual

[:SOURce] :LIST:MODE?

This command sets the operating mode for the current list or step sweep.

AUTO This choice enables the selected sweep type to perform a sweep of all points.

MANual This choice enables you to select a single sweep point. The selected point controls the frequency and/or amplitude according to the sweep type. Refer to “:LIST:MANual” on page 52 for selecting a sweep point.

***RST** AUTO

Key Entry Manual Mode Off On

:LIST:POWer

Supported All Models

[:SOURce] :LIST:POWer <val>{ , <val> }

[:SOURce] :LIST:POWer?

This command sets the amplitude for the current list sweep points.

Range Refer to “[:LEVel][:IMMediate][:AMPLitude]” on page 69 for output power ranges.

Remarks The setting enabled by this command is not affected by signal generator power-on, preset, or *RST.

During an amplitude sweep operation, signal generators with Option UNB or Option 506 protect the step attenuator by automatically switching to attenuator hold (OFF) mode. The attenuator is locked at its current setting and the amplitude sweep range is limited to 40 dB.

The maximum number of list sweep points is 1,601.

:LIST:POWer:POINTs

Supported All Models

[:SOURce] :LIST:POWer:POINTs?

This command queries the number of power points in the current list sweep file.

:LIST:RETRace

Supported All Models

```
[ :SOURce ] :LIST:RETRace ON|OFF|1|0
```

```
[ :SOURce ] :LIST:RETRace?
```

This command resets the single sweep to the first sweep point, or leaves it at the last sweep point upon completion of the sweep operation.

On (1) The sweep resets to the first sweep point.

Off (0) The sweep stays at the last sweep point.

***RST** 1

Key Entry Sweep Retrace Off On

:LIST:TRIGger:SOURce

Supported All Models

```
[ :SOURce ] :LIST:TRIGger:SOURce BUS|IMMEDIATE|EXTERNAL|KEY
```

```
[ :SOURce ] :LIST:TRIGger:SOURce?
```

This command sets the trigger source for a list or step sweep event.

To set the sweep trigger, see “:TRIGger[:SEQUence]:SOURce” on page 168.

BUS This choice enables GPIB triggering using the *TRG or GET command, or LAN and RS-232 triggering using the *TRG command.

IMMEDIATE This choice enables immediate triggering of the sweep event.

EXTERNAL This choice enables the triggering of a sweep event by an externally applied signal at the TRIGGER IN connector.

KEY This choice enables triggering by pressing the front-panel **Trigger** hardkey.

Example

```
:LIST:TRIG:SOUR BUS
```

The preceding example sets the trigger source to the instrument BUS.

***RST** IMM

Key Entry Bus Free Run Ext Trigger Key

:LIST:TYPE

Supported All Models

[:SOURCE] :LIST:TYPE LIST | STEP

[:SOURCE] :LIST:TYPE?

This command toggles between the two types of sweep.

LIST This type of sweep has arbitrary frequencies and amplitudes.

STEP This type of sweep has equally spaced frequencies and amplitudes.

***RST** STEP

Key Entry Sweep Type List Step

:LIST:TYPE:LIST:INITialize:FSTep

Supported All Models

CAUTION The current list sweep data will be overwritten once this command is executed. If needed, save the current data. Refer to “:STORE:LIST” on page 123 for storing list sweep files.

[:SOURCE] :LIST:TYPE:LIST:INITialize:FSTep

This command replaces the loaded list sweep data with the settings from the current step sweep data points.

Key Entry Load List From Step Sweep

Remarks You can have only one sweep list at a time.

The maximum number of list sweep points is 1,601. When copying the step sweep settings over to a list sweep, ensure that the number of points in the step sweep do not exceed the maximum list sweep points.

:LIST:TYPE:LIST:INITialize:PRESet

Supported All Models

CAUTION The current list sweep data will be overwritten once this command is executed. If needed, save the current data. Refer to “:STORE:LIST” on page 123 for storing list sweep files.

[:SOURce] :LIST:TYPE:LIST:INITialize:PRESet

This command replaces the current list sweep data with a factory-defined file consisting of one point at a frequency, amplitude, and dwell time.

Key Entry **Preset List**

:SWEep:DWELl

Supported All Models

[:SOURce] :SWEep:DWELl <val>

[:SOURce] :SWEep:DWELl?

This command enables you to set the dwell time for a step sweep.

The variable <val> is expressed in units of seconds with a 0.001 resolution.

NOTE The dwell time (<val>) does not begin until the signal generator has settled for the current frequency and/or amplitude change.

***RST** +2.00000000E-003

Range 0.001-60

Key Entry **Step Dwell**

Remarks Dwell time is used when the trigger source is set to IMMEDIATE. Refer to “:LIST:TRIGger:SOURce” on page 54 for the trigger setting.

The dwell time is the amount of time the sweep is guaranteed to pause after setting the frequency and/or power for the current point.

:SWEep:POINts

Supported All Models

[:SOURce] :SWEep:POINts <val>

[:SOURce] :SWEep:POINts?

This command defines the number of step sweep points.

***RST** 2

Range 2–65535

Key Entry # Points

Power Subsystem ([:SOURce]:POWer)

:ALC:BANDwidth|BWIDth

Supported All Models

```
[:SOURce]:POWer:ALC:BANDwidth|BWIDth 100HZ|1KHZ|10KHZ
[:SOURce]:POWer:ALC:BANDwidth|BWIDth?
```

This command sets the bandwidth of the automatic leveling control (ALC) loop. This is one of two commands that replace the `:DM:EXTernal:ALC:BANDwidth|BWIDth NORMal|NARRow` command. The `NARRow` parameter in the old command corresponds to the `100HZ` selection. The `NORMal` parameter in the old command corresponds to the `ON` parameter in the command [“:ALC:BANDwidth” on page 59](#).

100HZ	This choice selects a 100 Hz ALC bandwidth. This bandwidth has the longest settling time, but the least signal degradation and lowest error vector magnitude for digital signals. This is the auto selection for digital modulation.
1KHZ	This choice selects a 1 kHz ALC bandwidth. This bandwidth is the auto selection for pulse modulation and AM modulation to a carrier frequency of 500 kHz.
10KHZ	This choice selects a 10 kHz ALC bandwidth. This bandwidth has the fastest settling time, but the most signal degradation and highest error vector magnitude for digital signals. This is the auto selection for AM modulation above a 500 kHz carrier frequency and with FM/ΦM modulation.

Example

```
:POW:ALC:BWID 1KHZ
```

The preceding example sets the ALC bandwidth to 1 kHz.

```
*RST            10000
```

Key Entry **100 Hz 1kHz 10 kHz**

Remarks Use this command when the ALC is set to on. Refer to [“:ALC\[:STATe\]” on page 62](#) for selecting the ALC on or off state. Refer to the *E4428C/38C ESG Signal Generators User’s Guide* for information on ALC bandwidth.

:ALC:BANDwidth

Supported All Models

```
[ :SOURce ] :POWer:ALC:BANDwidth | BWIDth:AUTO ON | OFF | 1 | 0
[ :SOURce ] :POWer:ALC:BANDwidth | BWIDth:AUTO?
```

This command turns the bandwidth (BW) auto state on or off.

The bandwidth auto function allows the signal generator to automatically select a bandwidth for the automatic leveling control (ALC) circuit. This is one of two commands that replace the `:DM:EXTeRnal:ALC:BANDwidth | BWIDth NORMal | NARRow` command. The ON (1) selection in this command corresponds to the NORMal parameter in the old command. The NARRow parameter in the old command corresponds to the 100HZ parameter used with the command [“:ALC:BANDwidth|BWIDth” on page 58](#).

ON (1) This choice allows the signal generator to automatically select an ALC BW. The selection of the ALC BW depends on the signal generator modulation type as shown in the following table.

Modulation Type	Auto ALC Bandwidth Selection
Digital Modulation	100 Hz
Pulse Modulation	1 kHz
AM Modulation	10 kHz ¹ or 1 kHz
FM/ΦM Modulation	10 kHz

1. 10 kHz ALC bandwidth for carrier frequencies above 500 kHz

OFF (0) This choice disables automatic selection of the ALC BW, allowing you to select one of three ALC BWs: 100 Hz, 1 kHz, or 10 kHz. To select the desired ALC bandwidth, use the [“:ALC:BANDwidth|BWIDth” command shown on page 58](#).

***RST** 1

Key Entry **Auto**

Remarks For more information on ALC bandwidth, refer to the *E4428C/38C ESG Signal Generators User’s Guide*.

Power Subsystem ([:SOURCE]:POWER)

:ALC:LEVel

Supported All Models

```
[ :SOURCE ] :POWER:ALC:LEVel <value>dB  
[ :SOURCE ] :POWER:ALC:LEVel?
```

This command sets the automatic leveling control (ALC) level. Use this command after setting the attenuation auto mode to On. Refer to “:ATTenuation:AUTO” on page 65 for setting the attenuation auto mode.

The ALC is used to maintain the signal generator’s output power level by compensating for power fluctuations due to drift, band changes, or load variations. After you set the ALC level, the signal generator’s output power is monitored and corrected so that the power level setting is maintained.

Example

```
:POW:ALC:LEV 10DB
```

The preceding example sets the ALC to 10 dB.

***RST** +1.00000000E+000

Range -20 to 20

Key Entry Set ALC Level

:ALC:SEARCh

Supported All Models

```
[ :SOURCE ] :POWER:ALC:SEARCh ON|OFF|1|0|ONCE  
[ :SOURCE ] :POWER:ALC:SEARCh?
```

This command sets the internal power search mode. A power search is recommended for pulse-modulated signals with pulse widths less than one microsecond.

ON (1) This choice executes the power search automatically with each change in RF frequency or power.

OFF (0) This choice disables the automatic power search routine.

ONCE This choice executes a single power search of the current RF output signal.

***RST** 0

Key Entry Power Search Manual Auto Do Power Search

Remarks Use this command when the ALC state is set to OFF (0). Refer to “:ALC[:STATe]” on page 62 for setting the ALC state.

If ON was previously selected, executing ONCE will cause OFF to be the current

selection after the power search is completed.

:ALC:SEARCh:REFerence

Supported All Models

```
[ :SOURce ] :POWer:ALC:SEARCh:REFerence FIXed|MODulated  
[ :SOURce ] :POWer:ALC:SEARCh:REFerence?
```

This command sets either fixed or modulated modes of power search.

FIXed This choice uses a 0.5 volt reference.

MODulated This choice uses the RMS value of the current I/Q modulation.

***RST** MOD

Key Entry Power Search Reference Fixed Mod

:ALC:SEARCh:SPAN:START

Supported All Models

```
[ :SOURce ] :POWer:ALC:SEARCh:SPAN:START  
[ :SOURce ] :POWer:ALC:SEARCh:SPAN:START?
```

This command sets the start frequency for a span power search over a user specified range.

Key Entry Start Frequency

Remarks The start frequency has no default value. The start frequency value will be the last value set before powering off the instrument.

:ALC:SEARCh:SPAN:STOP:SPAN:STOP

Supported All Models

```
[ :SOURce ] :POWer:ALC:SEARCh:SPAN:STOP  
[ :SOURce ] :POWer:ALC:SEARCh:SPAN:STOP?
```

This command sets the stop frequency for a span power search over a user specified range.

Key Entry Stop Frequency

Remarks The stop frequency has no default value. The stop frequency value will be the last value set before powering off the instrument.

Power Subsystem (:SOURce):POWer)

:ALC:SEARch:SPAN:TYPE

Supported All Models

```
[ :SOURce ] :POWer:ALC:SEARch:SPAN:TYPE FULL|USER  
[ :SOURce ] :POWer:ALC:SEARch:SPAN:TYPE?
```

This command enables you to select the frequency range for a span power search. You can specify the range (USER) or you can select the full range (FULL) of the signal generator.

Key Entry Span Type User Full

:ALC:SEARch:SPAN[:STATe]

Supported All Models

```
[ :SOURce ] :POWer:ALC:SEARch:SPAN[:STATe] ON|OFF|1|0  
[ :SOURce ] :POWer:ALC:SEARch:SPAN[:STATe]?
```

This command enables (1) or disables (0) the span mode, allowing you to perform power searches over a selected range of frequencies. The power search corrections are then stored and used whenever the signal generator is tuned within the selected range.

:ALC[:STATe]

Supported All Models

```
[ :SOURce ] :POWer:ALC[:STATe] ON|OFF|1|0  
[ :SOURce ] :POWer:ALC[:STATe]?
```

This command enables or disables the automatic leveling control (ALC) circuit.

***RST** 1

Key Entry ALC Off On

Remarks The purpose of the ALC circuit is to hold output power at a desired level by adjusting the signal generator's power circuits to compensate for power drift. Power drift occurs over time and changes in temperature. Refer to the *E4428C/38C ESG Signal Generators User's Guide* for more information on the ALC.

:ALternate:AMPLitude

Supported All Models except signal generators with Option UNB or 506.

```
[ :SOURce ] :POWer:ALternate:AMPLitude <val>
```

```
[ :SOURce ] :POWer:ALternate:AMPLitude?
```

This command sets the delta value for the alternate amplitude.

The variable <val> is expressed in units of decibels (dB).

***RST** +0.00000000E+000

Range -156 to 156

Key Entry Alt Amp Delta

Remarks The actual RF output amplitude is equal to the Alternate Amplitude Delta value plus the RF output amplitude; this sum cannot exceed the minimum and maximum amplitude limits of the signal generator. For example, if the Alternate Amplitude Delta is set to -156 dB and the RF output amplitude is set to 20 dB, the sum is equal to -136 dB.

:ALternate:MANual

Supported All Models

```
[ :SOURce ] :POWer:ALternate:MANual MAIN|DELTA
```

```
[ :SOURce ] :POWer:ALternate:MANual?
```

This command toggles the alternate amplitude manual trigger source between main and alternate (delta).

MAIN The main power is present at the RF output.

DELTA The alternate power is present at the RF output.

***RST** MAIN

Key Entry Manual Trigger Main Delta

Remarks This command is effective only if MANual is the selection for the trigger source. Refer to “:ALternate:TRIGger[:SOURce]” on page 64 for more information.

Power Subsystem ([:SOURCE]:POWER)

:ALternate:STATe

Supported All Models

`[:SOURCE]:POWER:ALternate:STATe ON|OFF|1|0`

`[:SOURCE]:POWER:ALternate:STATe?`

This command enables or disables the alternate amplitude.

***RST** 0

Key Entry Alt Ampl Off On

:ALternate:TRIGger[:SOURCE]

Supported All Models except with Option UNB or 506

`[:SOURCE]:POWER:ALternate:TRIGger[:SOURCE] INTernal|EXTernal|MANual`

`[:SOURCE]:POWER:ALternate:TRIGger[:SOURCE]?`

This command sets the trigger source for the alternate amplitude signal.

INTernal This choice is available only for an E4438C with Option 001/601 or 002/602. The baseband generator triggers each timeslot to output a power level set with either the user-selected main or alternate amplitude parameter.

Each timeslot is allowed to output power with a user-selected main or alternate amplitude. This choice requires the Option 001/601 or 002/602 baseband generator option.

This choice requires a baseband generator option. Each timeslot is allowed to output power with a user-selected main or alternate amplitude.

EXTernal This choice requires an external trigger to the TRIG IN rear panel connector to toggle the RF output power between main and alternate amplitudes.

MANual This choice enables the RF output power to be toggled between main and alternate amplitudes using the front-panel **Trigger** hardkey.

***RST** MAN

Key Entry Int Ext Manual

:ATTenuation

Supported All Models

```
[:SOURCE]:POWER:ATTenuation <val><unit>  
[:SOURCE]:POWER:ATTenuation?
```

This command sets the signal generator's attenuator level. Before setting the attenuator level, set the “:ATTenuation:AUTO” function to Off which will disable ALC control.

In normal operation the attenuator level is selected by the signal generator's automatic loop control (ALC) which maintains the output power by adjusting internal circuits to compensate for any power fluctuations due to drift, band changes, or load variations. In some applications, such as fast pulse modulation, the ALC may not respond quickly enough to compensate for the pulse rise times. In this case you can set the attenuator and override any ALC adjustments.

The output power is the ALC level minus the attenuator setting. The attenuator is set in increments of 5 dB.

Example

```
:POW:ATT 10DB
```

The preceding example sets the attenuator to 10 dB.

***RST** +115

Range 0 to 115 dB

Key Entry Set Atten

:ATTenuation:AUTO

Supported All Models

```
[:SOURCE]:POWER:ATTenuation:AUTO ON|OFF|1|0  
[:SOURCE]:POWER:ATTenuation:AUTO?
```

This command sets the state of the attenuator auto mode function.

ON (1) This selection allows the signal generator's automatic loop control (ALC) to adjust the attenuator so that a specified RF power level, at the ESG's RF output connector, is maintained.

OFF (0) This choice allows for a user-selected attenuator setting that is not affected by the signal generator's ALC circuitry.

The OFF (0) selection can be used to eliminate power discontinuity normally associated with attenuator switching during power adjustments.

***RST** 1

Power Subsystem ([:SOURce]:POWer)

Key Entry **Atten Hold Off On**

Remarks During an amplitude sweep operation, signal generators with Option UNB or 506 protect the step attenuator from fast amplitude changes by automatically switching to attenuator auto Off mode. The attenuator is locked at its current setting and the amplitude sweep range is limited to 40 dB. Refer to the “:ALC:LEVel” on page 60 for more information.

:MODE

Supported All Models

```
[:SOURce]:POWer:MODE FIXed|LIST
[:SOURce]:POWer:MODE?
```

This command sets the signal generator power mode to fixed or swept.

FIXed This choice stops a power sweep, allowing the signal generator to operate at a fixed power level. Refer to “[:LEVel][:IMMediate][:AMPLitude]” on page 69 for setting the output power level.

LIST This choice selects the swept power mode. If sweep triggering is set to immediate along with continuous sweep mode, executing the command starts the LIST or STEP power sweep.

NOTE To perform a frequency and amplitude sweep, you must also select LIST as the frequency mode. See “:FREQUency:MODE” on page 42 for selecting the list mode for a frequency sweep.

***RST** FIX

Key Entry **Amplitude Ampl Off**

:REFerence

Supported All Models

```
[:SOURce]:POWer:REFerence <val><unit>
[:SOURce]:POWer:REFerence?
```

This command sets the power level for the signal generator RF output reference.

***RST** +0.00000000E+000

Range -400 to 300DBM

Key Entry **Ampl Ref Set**

Remarks The RF output power is referenced to the value entered in this command.

:REfERENCE:STATe

Supported All Models

```
[ :SOURce ] :POWer:REfERENCE:STATe ON|OFF|1|0  
[ :SOURce ] :POWer:REfERENCE:STATe?
```

This command enables or disables the RF output reference.

ON(1) This choice will set the power reference state to ON. The unit displayed for commands, “[:ANNotation:AMPLitude:UNIT](#)” on page 85 and “[:POWer](#)” on page 170 will be expressed in DB.

OFF(0) This choice will set the power reference state to OFF.

***RST** 0

Key Entry **Ampl Ref Off On**

Remarks Once the reference state is ON, all subsequent output power settings are set relative to the reference value.

Amplitude offsets can be used with the amplitude reference mode.

:START

Supported All Models

```
[ :SOURce ] :POWer:START <val><unit>  
[ :SOURce ] :POWer:START?
```

This command sets the first amplitude point in a step sweep.

***RST** -1.35000000E+002

Range Refer to “[\[:LEVel\]\[:IMMediate\]\[:AMPLitude\]](#)” on page 69 for the output power ranges.

Key Entry **Ampl Start**

Remarks During an amplitude sweep operation, signal generators with Option UNB or 506 protect the step attenuator by automatically switching to attenuator hold (ON) mode. The attenuator is locked at its current setting and the amplitude sweep range is limited to 40 dB.

Power Subsystem (:SOURce):POWER)

:STOP

Supported All Models

`[:SOURce] :POWER:STOP <val><unit>`

`[:SOURce] :POWER:STOP?`

This command sets the last amplitude point in a step sweep.

***RST** -1.35000000E+002

Range Refer to “[:LEVel][:IMMediate][:AMPLitude]” on page 69 for the output power ranges.

Key Entry **Ampl Stop**

Remarks During an amplitude sweep operation, signal generators with Option UNB or 506 protect the step attenuator by automatically switching to attenuator hold (ON) mode. The attenuator is locked at its current setting and the amplitude sweep range is limited to 40 dB.

[:LEVel][:IMMediate]:OFFSet

Supported All Models

`[:SOURce] :POWER[:LEVel] [:IMMediate] :OFFSet <val><unit>`

`[:SOURce] :POWER[:LEVel] [:IMMediate] :OFFSet?`

This command sets the power offset value.

***RST** +0.00000000E+000

Range -200DB to 200DB

Key Entry **Ampl Offset**

Remarks This simulates a power level at a test point beyond the RF OUTPUT connector without changing the actual RF output power. The offset value only affects the displayed amplitude setting.

You can enter an amplitude offset any time in either normal operation or amplitude reference mode.

[[:LEVel]][:IMMediate]][:AMPLitude]

Supported All Models

```
[ :SOURce ] :POWER [ :LEVel ] [ :IMMediate ] [ :AMPLitude ] <val><unit>
[ :SOURce ] :POWER [ :LEVel ] [ :IMMediate ] [ :AMPLitude ] ?
```

This command sets the RF output power.

***RST** -1.35000000E+002

Range	<i>Frequency</i>	<i>Standard</i>	<i>Option UNB</i>	<i>Option 506</i>
	250kHz–250MHz	-136 to 11dBm	-136 to 15dBm	-136 to 12dBm
	>250MHz–1GHz	-136 to 13dBm	-136 to 17dBm	-136 to 14dBm
	> 1–3GHz	-136 to 10dBm	-136 to 16dBm	-136 to 13dBm
	> 3–4GHz	-136 to 7dBm	-136 to 13dBm	-136 to 10dBm
	> 4–6GHz	N/A	N/A	-136 to 10dBm

Key Entry **Amplitude**

Remarks The ranges for this command are specified values from the data sheet.

[[:LEVel]][:IMMediate]][:AMPLitude]:STEP

Supported All Models

```
[ :SOURce ] :POWER [ :LEVel ] [ :IMMediate ] [ :AMPLitude ] :STEP [ :INCRement ]
<val><unit> | UP | DOWN
[ :SOURce ] :POWER [ :LEVel ] [ :IMMediate ] [ :AMPLitude ] :STEP [ :INCRement ] ?
```

This command sets the incremental step value for the amplitude parameter, or increments or decrements the current RF output power level by the specified <val> value.

<val> The increment power value.

UP Increases the current output power by the amount set with <val>. The front-panel up arrow key performs the same function.

DOWN Decreases the current output power by the amount set with <val>. The front-panel down arrow key performs the same function.

Range .02–100dB

Key Entry **Incr Set**

Remarks The value set with this command is not affected by *RST or a power cycle.

Basic Function Commands

Power Subsystem ([:SOURce]:POWer)

3 System Commands

This chapter provides SCPI descriptions for subsystems dedicated to peripheral signal generator operations common to all ESG models. This chapter contains the following major sections:

- “Calibration Subsystem (:CALibration)” on page 72
- “Communication Subsystem (:SYSTem:COMMunicate)” on page 75
- “Diagnostic Subsystem (:DIAGnostic[:CPU]:INFORmation)” on page 81
- “Display Subsystem (:DISPlay)” on page 85
- “IEEE 488.2 Common Commands” on page 88
- “Memory Subsystem (:MEMory)” on page 94
- “Mass Memory Subsystem (:MMEMory)” on page 124
- “Output Subsystem (:OUTPut)” on page 128
- “Route Subsystem (:ROUte:HARDware:DGENerator)” on page 130
- “Status Subsystem (:STATus)” on page 136
- “System Subsystem (:SYSTem)” on page 154
- “Trigger Subsystem” on page 166
- “Unit Subsystem (:UNIT)” on page 170

Calibration Subsystem (:CALibration)

:DCFM

Supported All

:CALibration:DCFM

This command initiates a DCFM or DC Φ M calibration depending on the currently active modulation. This calibration eliminates any dc or modulation offset of the carrier signal.

NOTE If the calibration is performed with a dc signal applied, any deviation provided by the dc signal will be removed and the new zero reference point will be at the applied dc level. The calibration will have to be performed again when the dc signal is disconnected to reset the carrier signal to the correct zero reference.

Key Entry DCFM/DCFM Cal

Remarks Use this calibration for externally applied signals. While the calibration can also be performed for internally generated signals, dc offset is not a normal characteristic for them.

:IQ

Supported E4438C

:CALibration:IQ

This command initiates an I/Q calibration.

Key Entry Execute Cal

:IQ:DC

Supported E4438C

:CALibration:IQ:DC

This command performs a one to two second adjustment that is not traceable to a standard. However, it will minimize errors associated with offset voltages. This adjustment minimizes errors for the current signal generator setting and at a single frequency. The DC adjustment is volatile and must be repeated with each signal generator setting change. This command can be sent while the RF On/Off is set to Off and the adjustment will still be valid when the RF is enabled.

The I/Q DC adjustment is dependent upon a number of instrument settings. If any of the instrument settings change, the adjustment will become invalid. The dependent instrument settings are:

- RF frequency
- I/Q attenuation level
- Baseband generator settings
- I/Q polarity settings
- Baseband filter settings
- Path settings (Internal I/Q Mux Path 1 or Path 2)
- I/Q calibration (the I/Q DC calibration will be invalidated if any other I/Q calibration is executed or if the **Revert to Factory Default** key is pressed)
- Temperature (± 5 degrees)

The following instrument states will not invalidate the I/Q DC calibration:

- Power level changes
- I/Q Impairments

Key Entry **Execute Cal** (with **Calibration Type User Full** set to DC)

:IQ:DEFault

Supported E4438C

`:CALibration:IQ:DEFault`

This command will restore the original factory calibration data for the internal I/Q modulator.

Key Entry **Revert to Default Cal Settings**

:IQ:FULL

Supported E4438C

`:CALibration:IQ:FULL`

This command performs an adjustment to the I/Q offset, gain and quadrature for the full-frequency range (regardless of the start and stop frequency settings) and stores the results in the signal generator's firmware.

Key Entry **Execute Cal** (with **Calibration Type User Full** set to Full)

Remarks Start and stop frequencies will default to the full frequency range of the signal generator.

Calibration Subsystem (:CALibration)

:IQ:START

Supported E4438C

:CALibration:IQ:START <val><unit>

:CALibration:IQ:START?

This command sets the start frequency and automatically sets the calibration type to User for an I/Q calibration.

Range Option 501: 100kHz–1GHz
Option 502: 100kHz–2GHz
Option 503: 100kHz–3GHz
Option 504: 100kHz–4GHz
Option 506: 100kHz–6GHz

Key Entry **Start Frequency**

Remarks The setting enabled by this command is not affected by signal generator power-on, preset, or *RST.

:IQ:STOP

Supported E4438C

:CALibration:IQ:STOP <val><unit>

:CALibration:IQ:STOP?

This command sets the stop frequency and automatically sets the calibration type to User for an I/Q calibration.

Range Option 501: 100kHz–1GHz
Option 502: 100kHz–2GHz
Option 503: 100kHz–3GHz
Option 504: 100kHz–4GHz
Option 506: 100kHz–6GHz

Key Entry **Stop Frequency**

Remarks The setting enabled by this command is not affected by signal generator power-on, preset, or *RST.

Communication Subsystem (:SYSTem:COMMunicate)

:GPIB:ADDRess

Supported All

```
:SYSTem:COMMunicate:GPIB:ADDRess <number>  
:SYSTem:COMMunicate:GPIB:ADDRess?
```

This command sets the signal generator's GPIB address.

Range 0–30

Key Entry GPIB Address

Remarks The setting enabled by this command is not affected by signal generator power-on, preset, or *RST.

:GTLocal

Supported All

```
:SYSTem:COMMunicate:GTLocal
```

This command sets the signal generator to local mode which enables front panel operation.

Key Entry Local

:LAN:CONFig

Supported All Models

```
:SYSTem:COMMunicate:LAN:CONFig DHCP|MANual  
:SYSTem:COMMunicate:LAN:CONFig?
```

This command sets the signal generator's internet protocol (IP) address.

MANual The user assigns an IP address to the signal generator.

DHCP The network assigns an IP address to the signal generator.

Example

```
:SYST:COMM:LAN:CONF DHCP
```

The preceding example sets up the signal generator LAN configuration to use a DHCP IP address.

Key Entry LAN Config

Communication Subsystem (:SYSTEM:COMMunicate)

:LAN:GATEway

Supported All

:SYSTEM:COMMunicate:LAN:GATEway "<ipstring>"

:SYSTEM:COMMunicate:LAN:GATEway?

This command sets the gateway for local area network (LAN) access to the signal generator from outside the current sub-network.

Key Entry Default Gateway

Remarks Using an empty string restricts access to the signal generator to local hosts on the LAN.

:LAN:HOSTname

Supported All

:SYSTEM:COMMunicate:LAN:HOSTname "<string>"

:SYSTEM:COMMunicate:LAN:HOSTname?

This command sets the signal generator's local area network (LAN) connection hostname.

Key Entry Hostname

Remarks The setting enabled by this command is not affected by signal generator power-on, preset, or *RST.

:LAN:IP

Supported All

:SYSTEM:COMMunicate:LAN:IP "<ipstring>"

:SYSTEM:COMMunicate:LAN:IP?

This command sets the signal generator's local area network (LAN) internet protocol (IP) address for your IP network connection.

Key Entry IP Address

Remarks The setting enabled by this command is not affected by signal generator power-on, preset, or *RST.

:LAN:SUBNet**Supported** All

```
:SYSTem:COMMunicate:LAN:SUBNet "<ipstring>"
:SYSTem:COMMunicate:LAN:SUBNet?
```

This command sets the signal generator's local area network (LAN) subnet mask address for your internet protocol (IP) network connection.

Key Entry Subnet Mask

Remarks The setting enabled by this command is not affected by signal generator power-on, preset, or *RST.

:PMETer:ADDRess**Supported** All

```
:SYSTem:COMMunicate:PMETer:ADDRess <val>
:SYSTem:COMMunicate:PMETer:ADDRess?
```

This command sets the address for a power meter that is controlled by the signal generator.

Range 0–30**Key Entry** Meter Address

Remarks The setting enabled by this command is not affected by signal generator power-on, preset, or *RST.

The power meter is controlled only through a GPIB cable.

Ensure that the power meter address is different from the signal generator address.

:PMETer:CHANnel**Supported** All

```
:SYSTem:COMMunicate:PMETer:CHANnel A|B
:SYSTem:COMMunicate:PMETer:CHANnel?
```

This command sets the measurement channel on the power meter that is controlled by the signal generator.

Key Entry Meter Channel A B

Remarks A single-channel power meter uses channel A and selecting channel B will have no effect.

Communication Subsystem (:SYSTEM:COMMunicate)

The setting enabled by this command is not affected by signal generator power-on, preset, or *RST.

The power meter is controlled only through a GPIB cable.

:PMETer:IDN

Supported All

:SYSTEM:COMMunicate:PMETer:IDN E4418B|E4419B|E4416A|E4417A

:SYSTEM:COMMunicate:PMETer:IDN?

This command sets the model number of the power meter that is controlled by the signal generator.

Key Entry Power Meter

Remarks The setting enabled by this command is not affected by signal generator power-on, preset, or *RST.

The power meter is controlled only through a GPIB cable.

:PMETer:TIMEout

Supported All

:SYSTEM:COMMunicate:PMETer:TIMEout <num>[<time suffix>]

:SYSTEM:COMMunicate:PMETer:TIMEout?

This command sets the period of time which the signal generator will wait for a valid reading from the power meter.

The variable <num> has a resolution of 0.001.

Range 1mS–100S

Key Entry Meter Timeout

Remarks The setting enabled by this command is not affected by signal generator power-on, preset, or *RST.

The power meter is controlled only through a GPIB cable.

If a time-out occurs, the signal generator reports an error message.

:SERial:BAUD

Supported All

```
:SYSTem:COMMunicate:SERial:BAUD <number>
```

```
:SYSTem:COMMunicate:SERial:BAUD?
```

This command sets the baud rate for the rear panel RS-232 interface labeled RS-232.

Key Entry **RS-232 Baud Rate**

Remarks The setting enabled by this command is not affected by signal generator power-on, preset, or *RST.

:SERial:ECHO

Supported All

```
:SYSTem:COMMunicate:SERial:ECHO ON|OFF
```

```
:SYSTem:COMMunicate:SERial:ECHO?
```

This command enables or disables the RS-232 echo.

Key Entry **RS-232 ECHO Off On**

Remarks The setting enabled by this command is not affected by signal generator power-on, preset, or *RST.

:SERial:RESet

Supported All

```
:SYSTem:COMMunicate:SERial:RESet
```

This event command resets the RS-232 buffer and will discard any unprocessed SCPI input received by the RS-232 port.

Key Entry **Reset RS-232**

:SERial:TOUT

Supported All

:SYSTEM:COMMunicate:SERial:TOUT <val>

:SYSTEM:COMMunicate:SERial:TOUT?

This command sets the RS-232 serial port time-out value.

If further input is not received within the time-out period specified, while a SCPI command is being processed, the command is aborted and the input buffer is cleared.

The variable <val> is entered in units of seconds.

Range 1–25

Key Entry RS-232 Timeout

Remarks The setting enabled by this command is not affected by signal generator power-on, preset, or *RST.

Diagnostic Subsystem (:DIAGnostic[:CPU]:INFORMATION)

:BOARDs

Supported All

:DIAGnostic[:CPU]:INFORMATION:BOARDs?

This query returns a list of the installed boards in the signal generator. The information will be returned in the following format:

"<board name,part number,serial number,version number,status>"

This information format will repeat with as many iterations as the number of detected boards in the signal generator.

Key Entry **Installed Board Info**

:CCOUNT:ATTenuator

Supported All

:DIAGnostic[:CPU]:INFORMATION:CCOUNT:ATTenuator?

This query returns the cumulative number of times that the attenuator has been switched.

Key Entry **Diagnostic Info**

:CCOUNT:PON

Supported All

:DIAGnostic[:CPU]:INFORMATION:CCOUNT:PON?

This query returns the cumulative number of times the signal generator has been powered-on.

Key Entry **Diagnostic Info**

:CCOUNT:PROTection

Supported All

:DIAGnostic[:CPU]:INFORMATION:CCOUNT:PROTection?

This query returns the cumulative number of times the reverse power protection has been cycled.

Key Entry **Diagnostic Info**

Diagnostic Subsystem (:DIAGnostic[:CPU]:INFORMATION)

:DISPlay:OTIME

Supported All Models

:DIAGnostic[:CPU]:INFORMATION:DISPlay:OTIME?

This query returns the cumulative number of hours the display has been on.

Key Entry Diagnostic Info

:LICense:AUXiliary

Supported E4438C with Option 001/600 or 002.602

:DIAGnostic[:CPU]:INFORMATION:LICense:AUXiliary?

This query returns a list of licenses for software applications associated with the signal generator that have the software license file installed on the PC, as opposed to a license key installed on the signal generator. However this query does not return demo licenses for Arb-based applications.

Key Entry Auxiliary Software Options

Remarks If you use the signal generator with a PC that has a copy of a software application for which a license shows with this query, the software automatically accesses and installs the license on the PC.

To access Arb-based demo software licenses, see “:LICense:WAVeform” . To view option numbers for software applications that use license keys, see “:OPTions” on page 83.

:LICense:WAVeform

Supported E4438C with Option 001/600 or 002/602

:DIAGnostic[:CPU]:INFORMATION:LICense:WAVeform?

This query returns a list of Arb-based licenses (including demo) for software applications associated with the signal generator that have the software license file installed on the PC, as opposed to a license key installed on the signal generator. These waveform licenses are created by the software application in a license file on the PC. Refer to “:WLICence[:VALue]” on page 84 for more information.

The response format is a series of comma-separated entries enclosed in quotation marks. The first field is the waveform type number and the second is a text description of the license.

Key Entry Waveform Licenses

Remarks If a license appears in this list, this means that you can transfer waveform files, created with the associated Arb-based software application to another signal generator if the other signal generator has the same license. For more information,

Diagnostic Subsystem (:DIAGnostic[:CPU]:INFORMATION)

refer to the command, “:LICense:AUXiliary” on page 82.

For a list of option numbers for software applications that use license keys, see “:OPTions”.

:OPTions

Supported All Models

:DIAGnostic[:CPU]:INFORMATION:OPTions?

This query returns a list of internally installed signal generator options.

Key Entry **Options Info**

:OPTions:DETail

Supported All Models

:DIAGnostic[:CPU]:INFORMATION:OPTions:DETail?

This query returns the options that are installed along with the option revision and DSP version if applicable.

Key Entry **Options Info**

:OTIME

Supported All Models

:DIAGnostic[:CPU]:INFORMATION:OTIME?

This query returns the cumulative number of hours that the signal generator has been on.

Key Entry **Diagnostic Info**

:REVision

Supported All Models

:DIAGnostic[:CPU]:INFORMATION:REVision?

This query returns the CPU bootstrap read only memory (boot ROM) revision date. In addition, the query returns the revision, creation date, and creation time of the main firmware.

Key Entry **Diagnostic Info**

Diagnostic Subsystem (:DIAGnostic[:CPU]:INFORMATION)

:SDATE

Supported All Models

`:DIAGnostic[:CPU]:INFORMATION:SDATE?`

This query returns the date and time of the main firmware.

Key Entry **Diagnostic Info**

:WLICence[:VALue]

Supported E4438C with Option 001/601 or 002/602

`:DIAGnostic[:CPU]:INFORMATION:WLICence[:VALue]? <type_num>`

This query returns the number of seconds remaining on the waveform license for the type of waveform designated by the <type_num> variable number. The type variable number is obtained using the “[:LICence:WAVEform](#)” command shown on [page 82](#). Zero is returned for non-existent and expired licenses. The value $2^{32} - 1$ (4,294,967,295) is returned for licenses that do not expire. Refer to the *E4428C/38C ESG Signal Generators Key and Data Field Reference* for information on the waveform licence.

Display Subsystem (:DISPlay)

:ANNotation:AMPLitude:UNIT

Supported All Models

```
:DISPlay:ANNotation:AMPLitude:UNIT DBM|DBUV|DBUVEMF|V|VEMF|DB  
:DISPlay:ANNotation:AMPLitude:UNIT?
```

This command sets the displayed front panel amplitude units.

If the amplitude reference state is set to on, the query returns units expressed in DB. Setting any other unit will cause a setting conflict error stating that the amplitude reference state must be set to off.

Refer to, “[:REFerence:STATe](#)” on page 67 for more information.

***RST** DBM

:ANNotation:CLOCK:DATE:FORMat

Supported All Models

```
:DISPlay:ANNotation:CLOCK:DATE:FORMat MDY|DMY  
:DISPlay:ANNotation:CLOCK:DATE:FORMat?
```

This command enables the selection of the date format. The choices are month-day-year (MDY) or day-month-year (DMY) format.

Remarks The setting enabled by this command is not affected by signal generator power-on, preset, or *RST.

:ANNotation:CLOCK[:STATe]

Supported All Models

```
:DISPlay:ANNotation:CLOCK[:STATe] ON|OFF|1|0  
:DISPlay:ANNotation:CLOCK[:STATe] ?
```

This command enables or disables the digital clock view in the lower right side of the front panel display.

Remarks The setting enabled by this command is not affected by signal generator power-on, preset, or *RST.

Display Subsystem (:DISPlay)

:BRIGhtness

Supported All Models

:DISPlay:BRIGhtness <val>

:DISPlay:BRIGhtness?

This command sets the display brightness (intensity). The brightness can be set to the minimum level (0.02), maximum level (1), or in between by using fractional numeric values (0.03–0.99).

Range 0.02–1

Key Entry **Brightness**

Remarks The setting enabled by this command is not affected by signal generator power-on, preset, or *RST.

:CAPTure

Supported All Models

:DISPlay:CAPTure

This event command enables the user to capture the current display and store it in the signal generator’s memory.

Remarks The display capture is stored as DISPLAY.BMP in the Binary file system. This file is overwritten with each subsequent display capture. The file can be down-loaded in the following manner:

1. Log on to the signal generator using ftp.
2. Change (cd) to the BIN directory.
3. Retrieve the file by using the get command.

:CONTRast

Supported All Models

:DISPlay:CONTRast <val>

:DISPlay:CONTRast?

This command sets the contrast of the LCD display. The contrast can be set to the maximum level (1), minimum level (0), or in between by using fractional numeric values (0.001–0.999).

Range 0–1

Key Entry Display contrast hardkeys are located below the display.

Remarks The setting enabled by this command is not affected by signal generator power-on, preset, or *RST.

:INVerse

Supported All Models

:DISPlay:INVerse ON|OFF|1|0

:DISPlay:INVerse?

This command sets the display of the source to inverse video mode.

Key Entry **Inverse Video Off On**

Remarks The setting enabled by this command is not affected by signal generator power-on, preset, or *RST.

:REMote

Supported All Models

:DISPlay:REMote ON|OFF|1|0

:DISPlay:REMote?

This command enables or disables the display updating when the signal generator is remotely controlled.

ON (1) This choice updates the signal generator display so you can see the settings as the commands are executed, however, this will degrade the signal generator speed.

OFF (0) This choice turns off the display updating while further optimizing the signal generator for speed.

Key Entry **Update in Remote Off On**

Remarks The setting enabled by this command is not affected by signal generator preset or *RST. However, cycling the signal generator power will reset it to zero.

[:WINDow][:STATe]

Supported All Models

:DISPlay[:WINDow][:STATe] ON|OFF|1|0

:DISPlay[:WINDow][:STATe]?

This command is used to either blank out (OFF or 0) the display screen or turn it on (ON or 1).

Remarks The setting enabled by this command is not affected by *RST. However, presetting the signal generator or cycling the power will turn the display on.

IEEE 488.2 Common Commands

*CLS

Supported All Models

*CLS

The Clear Status (CLS) command clears the Status Byte Register, the Data Questionable Event Register, the Standard Event Status Register, the Standard Operation Status Register and any other registers that are summarized in the status byte.

*ESE

Supported All Models

*ESE <data>

The Standard Event Status Enable (ESE) command sets the Standard Event Status Enable Register.

The variable <data> represents the sum of the bits that will be enabled.

Range 0–255

Remarks The setting enabled by this command is not affected by signal generator preset or *RST. However, cycling the signal generator power will reset this register to zero.

Refer to Chapter 3 of the *E4428C/38C ESG Signal Generators Programming Guide* for more information.

*ESE?

Supported All Models

*ESE?

The Standard Event Status Enable (ESE) query returns the value of the Standard Event Status Enable Register.

Remarks Refer to Chapter 3 of the *E4428C/38C ESG Signal Generators Programming Guide* for more information.

*ESR?

Supported All Models

CAUTION This is a destructive read. The data in the register is latched until it is queried. Once queried, the data is cleared.

*ESR?

The Standard Event Status Register (ESR) query returns the value of the Standard Event Status Register.

Remarks Refer to Chapter 3 of the *E4428C/38C ESG Signal Generators Programming Guide* for more information.

*IDN?

Supported All Models

*IDN?

The Identification (IDN) query outputs an identifying string. The response will show the following information:

<company name>, <model number>, <serial number>, <firmware revision>

Key Entry **Diagnostic Info**

Remarks The identification information can be modified. Refer to [“:IDN” on page 156](#) for more information.

*OPC

Supported All Models

*OPC

The Operation Complete (OPC) command sets bit 0 in the Standard Event Status Register when all pending operations have finished.

***OPC?**

Supported All Models

*OPC?

The Operation Complete (OPC) query returns the ASCII character 1 in the Standard Event Status Register when all pending operations have finished.

***OPT?**

Supported All Models

*OPT?

The options (OPT) query returns a comma-separated list of all of the instrument options currently installed on the signal generator.

Key Entry **Instrument Options**

***PSC**

Supported

*PSC ON|OFF|1|0

The Power-On Status Clear (PSC) command controls the automatic power-on clearing of the Service Request Enable Register, the Standard Event Status Enable Register, and device-specific event enable registers.

ON (1) This choice enables the power-on clearing of the listed registers.

OFF (0) This choice disables the clearing of the listed registers and they retain their status when a power-on condition occurs.

Remarks The setting enabled by this command is not affected by signal generator power-on, preset, or *RST.

***PSC?**

Supported All Models

*PSC?

The Power-On Status Clear (PSC) query returns the flag setting as enabled by the *PSC command.

***RCL**

Supported All Models

***RCL** <reg>, <seq>

The Recall (RCL) command recalls the state from the specified memory register <reg> of the specified sequence <seq>.

Range Registers: 0–99 Sequences: 0–9

Key Entry **RECALL Reg** **Select Seq:**

***RST**

Supported All Models

***RST**

The Reset (RST) command resets most signal generator functions to factory-defined conditions.

Remarks Each command shows the *RST value if the setting is affected.

***SAV**

Supported All Models

***SAV** <reg>, <seq>

The Save (SAV) command saves signal generator settings to the specified memory register <reg> of the specified sequence <seq>.

Range Registers: 0–99 Sequences: 0–9

Key Entry **Save Reg** **Save Seq[n] Reg[nn]**

Remarks The save function does not save all signal generator settings. Refer to the *E4428C/38C ESG Signal Generators User's Guide* for more information on the save function. Refer to [“*RCL” on page 90](#) for information on recalling saved signal generator settings.

***SRE**

Supported All Models

***SRE** <data>

The Service Request Enable (SRE) command sets the value of the Service Request Enable Register.

The variable <data> is the decimal sum of the bits that will be enabled. Bit 6 (value 64) is ignored and cannot be set by this command.

Range 0–255

Remarks Refer to Chapter 3 of the *E4428C/38C ESG Signal Generators Programming*

Guide for more information.

Entering values from 64 to 127 is equivalent to entering values from 0 to 63.

The setting enabled by this command is not affected by signal generator preset or *RST. However, cycling the signal generator power will reset it to zero.

***SRE?**

Supported All Models

*SRE?

The Service Request Enable (SRE) query returns the value of the Service Request Enable Register.

Range 0–63 or 128–191

Remarks Refer to Chapter 3 of the *E4428C/38C ESG Signal Generators Programming Guide* for more information.

***STB?**

Supported All Models

*STB?

The Read Status Byte (STB) query returns the value of the status byte including the master summary status (MSS) bit.

Range 0–255

Remarks Refer to Chapter 3 of the *E4428C/38C ESG Signal Generators Programming Guide* for more information.

***TRG**

Supported All Models

*TRG

The Trigger (TRG) command triggers the device if BUS is the selected trigger source, otherwise, *TRG is ignored.

***TST?**

Supported All Models

*TST?

The Self-Test (TST) query initiates the internal self-test and returns one of the following results:

- 0 This shows that all tests passed.
- 1 This shows that one or more tests failed.

Key Entry Run Complete Self Test

***WAI**

Supported All Models

*WAI

The Wait-to-Continue (WAI) command causes the signal generator to wait until all pending commands are completed, before executing any other commands.

Memory Subsystem (:MEMory)

:CATalog:BINary

Supported E4438C with Option 001/601 or 002/602

:MEMory:CATalog:BINary?

This command outputs a list of the binary files. The return data will be in the following form:

```
<mem used>,<mem free>{,"<file listing>"}
```

The signal generator will return the two memory usage parameters and as many file listings as there are files in the directory list. Each file listing parameter will be in the following form:

```
"<file name,file type,file size>"
```

Key Entry Binary

Remarks Refer to [“File Name Variables” on page 13](#) for information on the file name syntax.

:CATalog:BIT

Supported E4438C with Option 001/601 or 002/602

:MEMory:CATalog:BIT?

This command outputs a list of the bit files. The return data will be in the following form:

```
<mem used>,<mem free>{,"<file listing>"}
```

The signal generator will return the two memory usage parameters and as many file listings as there are files in the directory list. Each file listing parameter will be in the following form:

```
"<file name,file type,file size>"
```

Key Entry Bit

Remarks Refer to [“File Name Variables” on page 13](#) for information on the file name syntax.

:CATalog:CDMa

NOTE Refer to the *E4428C/38C ESG Signal Generators Programming Compatibility Guide* for information on this command. This command is still valid for backward compatibility and was replaced by “:CATalog:CDMA” .

:CATalog:CDMA

Supported E4438C with Option 401

:MEMory:CATalog:CDMA?

This command outputs a list of the arbitrary waveform CDMA files. The return data will be in the following form:

```
<mem used>,<mem free>{,"<file listing>"}
```

The signal generator will return the two memory usage parameters and as many file listings as there are files in the directory list. Each file listing parameter will be in the following form:

```
"<file name,file type,file size>"
```

Key Entry CDMA

Remarks Refer to “[File Name Variables](#)” on page 13 for information on the file name syntax.

:CATalog:DMOD

Supported E4438C with Option 001/601or 002/602

:MEMory:CATalog:DMOD?

This command outputs a list of the arbitrary waveform digital modulation files. The return data will be in the following form:

```
<mem used>,<mem free>{,"<file listing>"}
```

The signal generator will return the two memory usage parameters and as many file listings as there are files in the directory list. Each file listing parameter will be in the following form:

```
"<file name,file type,file size>"
```

Key Entry DMOD

Remarks Refer to “[File Name Variables](#)” on page 13 for information on the file name syntax.

Memory Subsystem (:MEMory)

:CATalog:DWCDma

Supported E4438C with Option 400

:MEMory:CATalog:DWCDma?

This command outputs a list of the arbitrary waveform downlink W-CDMA files. The return data will be in the following form:

```
<mem used>,<mem free>{,"<file listing>"}
```

The signal generator will return the two memory usage parameters and as many file listings as there are files in the directory list. Each file listing parameter will be in the following form:

```
"<file name,file type,file size>"
```

Key Entry DWCDMA

Remarks Refer to [“File Name Variables” on page 13](#) for information on the file name syntax.

:CATalog:FCDMa

Supported E4438C with Option 401

:MEMory:CATalog:FCDMa?

This command outputs a list of the arbitrary waveform forward link cdma2000 files. The return data will be in the following form:

```
<mem used>,<mem free>{,"<file listing>"}
```

The signal generator will return the two memory usage parameters and as many file listings as there are files in the directory list. Each file listing parameter will be in the following form:

```
"<file name,file type,file size>"
```

Key Entry FCDMA

Remarks Refer to [“File Name Variables” on page 13](#) for information on the file name syntax.

:CATalog:FIR

Supported E4438C with Option 001/601or 002/602

:MEMory:CATalog:FIR?

This command outputs a list of the finite impulse response filter files. The return data will be in the following form:

```
<mem used>,<mem free>{,"<file listing>"}
```

The signal generator will return the two memory usage parameters and as many file listings as there are files in the directory list. Each file listing parameter will be in the following form:

```
"<file name,file type,file size>"
```

Key Entry FIR

Remarks Refer to [“File Name Variables” on page 13](#) for information on the file name syntax.

:CATalog:FSK

Supported E4438C with Option 001/601or 002/602

:MEMory:CATalog:FSK?

This command outputs a list of the FSK files. The return data will be in the following form:

```
<mem used>,<mem free>{,"<file listing>"}
```

The signal generator will return the two memory usage parameters and as many file listings as there are files in the directory list. Each file listing parameter will be in the following form:

```
"<file name,file type,file size>"
```

Key Entry FIR

Remarks Refer to [“File Name Variables” on page 13](#) for information on the file name syntax.

Memory Subsystem (:MEMory)

:CATalog:IQ

Supported E4438C with Option 001/601or 002/602

:MEMory:CATalog:IQ?

This command outputs a list of the IQ files. The return data will be in the following form:

<mem used>,<mem free>{,"<file listing>"}

The signal generator will return the two memory usage parameters and as many file listings as there are files in the directory list. Each file listing parameter will be in the following form:

"<file name,file type,file size>"

Key Entry IQ

Remarks Refer to [“File Name Variables” on page 13](#) for information on the file name syntax.

:CATalog:LIST

Supported All Models

:MEMory:CATalog:LIST?

This command outputs a list of the list sweep files. The return data will be in the following form:

<mem used>,<mem free>{,"<file listing>"}

The signal generator will return the two memory usage parameters and as many file listings as there are files in the directory list. Each file listing parameter will be in the following form:

"<file name,file type,file size>"

Key Entry List

Remarks Refer to [“File Name Variables” on page 13](#) for information on the file name syntax.

:CATalog:MCDMa

Supported E4438C with Option 401

:MEMory:CATalog:MCDMa?

This command outputs a list of the arbitrary waveform multicarrier IS-95 CDMA files. The return data will be in the following form:

```
<mem used>,<mem free>{,"<file listing>"}
```

The signal generator will return the two memory usage parameters and as many file listings as there are files in the directory list. Each file listing parameter will be in the following form:

```
"<file name,file type,file size>"
```

Key Entry MCDMA

Remarks Refer to [“File Name Variables” on page 13](#) for information on the file name syntax.

:CATalog:MDMod

Supported E4438C with Option 001/601or 002/602

:MEMory:CATalog:MDMod?

This command outputs a list of the arbitrary waveform multicarrier digital modulation files. The return data will be in the following form:

```
<mem used>,<mem free>{,"<file listing>"}
```

The signal generator will return the two memory usage parameters and as many file listings as there are files in the directory list. Each file listing parameter will be in the following form:

```
"<file name,file type,file size>"
```

Key Entry MDMOD

Remarks Refer to [“File Name Variables” on page 13](#) for information on the file name syntax.

Memory Subsystem (:MEMory)

:CATalog:MDWCdma

Supported E4438C with Option 400

:MEMory:CATalog:MDWCdma?

This command outputs a list of the arbitrary waveform multicarrier downlink W-CDMA files. The return data will be in the following form:

```
<mem used>,<mem free>{,"<file listing>"}
```

The signal generator will return the two memory usage parameters and as many file listings as there are files in the directory list. Each file listing parameter will be in the following form:

```
"<file name,file type,file size>"
```

Key Entry MDWCDMA

Remarks Refer to [“File Name Variables” on page 13](#) for information on the file name syntax.

:CATalog:MFCdma

Supported E4438C with Option 401

:MEMory:CATalog:MFCdma?

This command outputs a list of the arbitrary waveform multicarrier forward link cdma2000 files. The return data will be in the following form:

```
<mem used>,<mem free>{,"<file listing>"}
```

The signal generator will return the two memory usage parameters and as many file listings as there are files in the directory list. Each file listing parameter will be in the following form:

```
"<file name,file type,file size>"
```

Key Entry MFCDMA

Remarks Refer to [“File Name Variables” on page 13](#) for information on the file name syntax.

:CATalog:MTONe

Supported E4438C with Option 001/601 or 002/602

:MEMory:CATalog:MTONe?

This command outputs a list of the arbitrary waveform multitone files. The return data will be in the following form:

```
<mem used>,<mem free>{,"<file listing>"}
```

The signal generator will return the two memory usage parameters and as many file listings as there are files in the directory list. Each file listing parameter will be in the following form:

```
"<file name,file type,file size>"
```

Key Entry MTONE

Remarks Refer to [“File Name Variables” on page 13](#) for information on the file name syntax.

:CATalog:RCDMa

Supported E4438C with Option 401

:MEMory:CATalog:RCDMa?

This command outputs a list of the arbitrary waveform files for reverse link cdma2000. The return data will be in the following form:

```
<mem used>,<mem free>{,"<file listing>"}
```

The signal generator will return the two memory usage parameters and as many file listings as there are files in the directory list. Each file listing parameter will be in the following form:

```
"<file name,file type,file size>"
```

Key Entry RCDMA

Remarks Refer to [“File Name Variables” on page 13](#) for information on the file name syntax.

:CATalog:SEQ

Supported E4438C with Option 001/601or 002/602

:MEMory:CATalog:SEQ?

This command outputs a list of the arbitrary waveform sequence files. The return data will be in the following form:

```
<mem used>,<mem free>{,"<file listing>"}
```

The signal generator will return the two memory usage parameters and as many file listings as there are files in the directory list. Each file listing parameter will be in the following form:

```
"<file name,file type,file size>"
```

Key Entry SEQ

Remarks Refer to [“File Name Variables” on page 13](#) for information on the file name syntax.

:CATalog:SHAPE

Supported E4438C with Option 001/601or 002/602

:MEMory:CATalog:SHAPE?

This command outputs a list of the burst shape files. The return data will be in the following form:

```
<mem used>,<mem free>{,"<file listing>"}
```

The signal generator will return the two memory usage parameters and as many file listings as there are files in the directory list. Each file listing parameter will be in the following form:

```
"<file name,file type,file size>"
```

Key Entry SHAPE

Remarks Refer to [“File Name Variables” on page 13](#) for information on the file name syntax.

:CATalog:STATE

Supported All Models

:MEMory:CATalog:STATE?

This command outputs a list of the state files. The return data will be in the following form:

```
<mem used>,<mem free>{,"<file listing>"}
```

The signal generator will return the two memory usage parameters and as many file listings as there are files in the directory list. Each file listing parameter will be in the following form:

```
"<file name,file type,file size>"
```

Key Entry State

Remarks Refer to [“File Name Variables” on page 13](#) for information on the file name syntax.

:CATalog:UFLT

Supported All Models

:MEMory:CATalog:UFLT?

This command outputs a list of the user-flatness correction files. The return data will be in the following form:

```
<mem used>,<mem free>{,"<file listing>"}
```

The signal generator will return the two memory usage parameters and as many file listings as there are files in the directory list. Each file listing parameter will be in the following form:

```
"<file name,file type,file size>"
```

Key Entry User Flatness

Remarks Refer to [“File Name Variables” on page 13](#) for information on the file name syntax.

:CATalog:UWCDma

Supported E4438C with Option 400

:MEMory:CATalog:UWCDma?

This command outputs a list of the arbitrary waveform uplink W-CDMA files. The return data will be in the following form:

```
<mem used>,<mem free>{,"<file listing>"}
```

The signal generator will return the two memory usage parameters and as many file listings as there are files in the directory list. Each file listing parameter will be in the following form:

```
"<file name,file type,file size>"
```

Key Entry UWCDMA

Remarks Refer to [“File Name Variables” on page 13](#) for information on the file name syntax.

:CATalog[:ALL]

Supported All Models

:MEMory:CATalog[:ALL]?

This command outputs a list of all the files in the memory subsystem. However it does not include files stored on the Option 001/601 or 002/602 baseband generator. The return data will be in the following form:

```
<mem used>,<mem free>{,"<file listing>"}
```

The signal generator will return the two memory usage parameters and as many file listings as there are files in the memory subsystem. Each file listing parameter will be in the following form:

```
"<file name,file type,file size>"
```

Key Entry All

Remarks Refer to the [Table on page 14](#) for a listing of the file types and [“File Name Variables” on page 13](#) for information on the "<file name>" syntax.

:COPY[:NAME]

Supported All Models

```
:MEMory:COPY[:NAME] "<file name>","<file name>"
```

This command makes a duplicate of the requested file.

Key Entry Copy File

Remarks Refer to “[File Name Variables](#)” on page 13 for information on the file name syntax.

When copying a waveform file from volatile to non-volatile memory, the marker file and file header, associated with the waveform file, will automatically be copied at the same time.

:DATA

Supported E4438C with Option 001/601 or 002/602

```
:MEMory:DATA "<file_name>",<data_block>
```

```
:MEMory:DATA? "<file_name>"
```

This command loads waveform data into signal generator memory using the `<data_block>` parameter and saves the data to a file designated by the `"<file_name>"` variable. The query returns the file contents of the file as a datablock.

The waveform file must be located in volatile waveform memory (WFM1) before it can be played by the signal generator’s dual ARB player.

For downloads directly into volatile waveform memory use the path `"WFM1:<file_name>"`. For downloads to non-volatile waveform memory, use the path `"NVWFM:<file_name>"`.

`"<file_name>"` This variable names the destination file, including the directory path.

`<data_block>` This parameter represents the data and file length parameters. The data in the file is represented by the `<data_block>` variable.

Refer to the *E4428C/38C ESG Signal Generators Programming Guide* for more information on programming the status registers.

NOTE ARB waveform files created using the :DATA command cannot be retrieved or uploaded. Attempting to do so will cause the signal generator to display the message: `ERROR:221, Access denied`. To download ARB data to files for later retrieval, use the `“:DATA:UNPRotected”` command on [page 116](#).

Memory Subsystem (:MEMory)

Example

```
:MEM:DATA "NVWFM:IQ_Data",#210Qaz37pY9oL
```

The preceding example downloads 10 bytes of data to a file, IQ_Data., in the signal generator's non-volatile memory. The table shown below describes the command parameters.

- "NVWFM:IQ_Data" IQ_Data is the file name. The directory path is not needed. The path "/USER/WAVEFORM/" is implied.
- #210Qaz37pY9oL Data block
 - # This character indicates the beginning of the data block
 - 2 Number of digits in the byte count
 - 10 Byte count
 - Qaz37pY9oL 10 bytes of data

NOTE The data, Qaz37pY9oL, in the above command are not valid and are shown for example purposes only. Typically, ascii characters representing data are unprintable.

Remarks See [“File Name Variables” on page 13](#) for information on the file name syntax.

:DATA:APPend

Supported E4438C with Option 001/601 or 002/602

```
:MEMory:DATA:APPend "<file_name>",<data_block>
```

This commands appends data to an existing file stored in signal generator memory.

"<file_name>" This variable names the destination file and directory path.

<data_block> This parameter represents the data and file length parameters. The data in the file is represented by the <data_block> variable. The file length parameters are used by the signal generator for allocating memory.

Refer to the *E4428C/38C ESG Signal Generators Programming Guide* for more information on downloading and using files.

Example

```
:MEM:DATA:APPend "NVWFM:IQ_Data",#14Y9oL
```

The preceding example downloads and appends the data, Y9oL, to an existing file named IQ_Data stored in the signal generator’s non-volatile memory (NVWFM).

- "NVWFM:IQ_Data" IQ_Data the file name. The directory path is not needed. The path "/USER/WAVEFORM/" is implied.
- #14Y9oL Data block
 - # This character indicates the beginning of the data block
 - 1 Number of digits in the byte count
 - 4 Byte count
 - Y9oL 4 bytes of data

Remarks Refer to [“File Name Variables” on page 13](#) for information on the file name syntax.

:DATA:BIT

Supported E4438C with Option 001/601or 002/602

```
:MEMory:DATA:BIT "<file_name>",<bit_count>,<data_block>
:MEMory:DATA:BIT? "<file_name>"
```

This command loads bit data into signal generator memory using the <bit_count> and <data_block> parameters and saves the data to a file designated by the "<file_name>" variable. The query returns the bit count, file length information, and the data.

<file_name> This variable names the destination file and the directory path.

<bit_count> This number represents the number of bits in the data block.

<data_block> This parameter represents the data and file length parameters. The data in the file is represented by the <data_block> variable. The file length parameters are used by the signal generator for allocating memory.

Refer to the *E4428C/38C ESG Signal Generators Programming Guide* for more information on downloading and using files.

Example

```
:MEM:DATA:BIT "Test_Data",16,#12Qz
```

The preceding example downloads bit data to the file, Test_Data. The table below describes the command parameters.

System Commands

Memory Subsystem (:MEMory)

- "Test_Data" Test_Data is the file name. The directory path is not needed. The path "/USER/BIT/" is implied.
- 16 Number of bits in the data block
- #12Qz Data block
 - # This character indicates the beginning of the data block
 - 1 Number of digits in the byte count
 - 2 Byte count
 - Qz 16 bits of data (ascii representation of bit data)

Remarks Refer to [“File Name Variables” on page 13](#) for information on the file name syntax.

:DATA:FIR

Supported E4438C with Option 001/601 or 002/602

```
:MEMory:DATA:FIR "<file_name>",osr,coefficient{,coefficient}
```

```
:MEMory:DATA:FIR? "<file_name>"
```

This command loads oversample ratio (OSR) and user-defined finite impulse response (FIR) coefficient data into a file in the signal generator's non-volatile memory (NVWFM). The query returns the oversample ratio and coefficient data.

"<file_name>" This variable is the file name of the destination file. The directory path, /USER/FIR is not required as it is implied by the command.

osr The OSR is the number of filter taps per symbol.

coefficient This variable is the FIR coefficient. The maximum number of coefficients is 1024.

{,coefficient} This optional variable is used when you enter additional coefficients.

Refer to the *E4428C/38C ESG Signal Generators Programming Guide* for more information on downloading and using files.

Example

```
:MEM:DATA:FIR "FIR_1",4,0,0,0,0,0,0.000001,0.000012,0.000132,  
0.001101,0.006743,0.030588,0.103676,0.265790,0.523849,0.809508,1,1,  
0.809508,0.523849,0.265790,0.103676,0.030588,0.006743,0.001101,0.000132,  
0.000012,0.000001,0,0,0,0,0
```

The preceding example downloads FIR coefficient and oversampling ratio data to the signal generator's non-volatile memory in a file named FIR_1. Notice that the signal generator directory

path, /USER/FIR, is not needed as it is implied by the command. Refer to “File Name Variables” on page 13 for information on the file name syntax.

Range *osr*: 1–32
 coefficient: –1000 to 1000

Key Entry **Oversample Ratio**

:DATA:FSK

Supported E4438C with Option 001/601or 002/602

```
:MEMory:DATA:FSK "<file_name>", <num_states>, <f0>, <f1>, ...<f (n) >
[,<diff_state>, <num_diff_states>, <diff1>, ...<diff (n) >]
:MEMory:DATA:FSK? "<file_name>"
```

This command loads custom frequency shift keying (FSK) data into a file in the signal generator’s non-volatile memory (NVWFM).

The query returns data in the following form:

```
<num_states>, <f0>, <f1>, ...<f (n) >, <diff_state>, <num_diff_states>, <diff1>,
...<diff (n) >
```

"<file_name>" This variable string identifies the name of the FSK file. The filename must be enclosed with quotation marks.

<num_states> This variable identifies the number of frequency states.

<f0> This variable identifies the value of the first frequency state.

<f1>,...<f (n) > This variable identifies the value of the second and subsequent frequency states with a frequency resolution of 0.1Hz.

<diff_state> This variable enables or disables differential encoding.

<num_diff_states> This variable identifies the number of differential states.

<diff0> This variable identifies the value of the first differential state.

<diff1>,...<diff (n) > This variable identifies the value of the second and subsequent differential states.

Refer to the *E4428C/38C ESG Signal Generators Programming Guide* for more information on downloading and using files.

Memory Subsystem (:MEMory)

Example

:MEM:DATA:FSK "4FSK", 4, -2kHz, -1kHz, 2kHz, 1kHz, ON, 2, 1, 0

The preceding example downloads a four-level FSK data to a file named 4FSK. There are four states (frequencies): -2kHz, -1kHz, 2kHz, 1kHz; differential encoding is toggled ON, and there are two differential states 1 and 0. The table shown below describes the command parameters.

- "4FSK" 4FSK is the FSK file name. The directory path is not needed. The path "/USER/FSK" is implied.
- 4 Number of states
- -2kHz First frequency state
- -1kHz Second frequency state
- 2kHz Third frequency state
- 1kHz Fourth frequency state
- ON Differential encoding is on
- 2 Number of differential states
- 1 Value of the first differential state.
- 0 Value of the second differential state.

Range *num_diff_states:* 0–256
num_states: 2–16
f0–f(n): -20MHZ to 20MHZ
diff0–diff(n): -128 to 127

Remarks Refer to “File Name Variables” on page 13 for information on the file name syntax.

:DATA:IQ

Supported E4438C with Option 001/601or 002/602

```
:MEMory:DATA:IQ "<file_name>",<offsetQ>,<num_states>,<i0>,<q0>,<i1>,<q1>,...<i (n)>,<q (n)>[,<diff_state>,<num_diff_states>,<diff0>,<diff1>,...<diff (n)>]
:MEMory:DATA:IQ? "<file_name>"
```

This command loads custom I/Q data into a file in the signal generator’s non-volatile waveform memory (NVWFM).

The query returns data in the following form:

<offsetQ>, <num_states>, <i0>, <q0>, <i1>, <q1>, ... <i(n)>, <q(n)>, <diff_state>
 , <num_diff_states>, <diff0>, <diff1>, ... <diff(n)>

"<file_name>" This variable string identifies the name of the I/Q file. The filename must be enclosed with quotation marks.

<offsetQ> This variable enables (1) or disables (0) the Q output delay by 1/2 symbol from the I output.

<num_states> This is the number of symbols.

<i0>...<i(n)> This is the I value of the first and subsequent I symbols.

<q0>...<q(n)> This is the Q value of the first and subsequent Q symbols.

<diff_state> This variable enables and disables differential encoding.

<num_diff_states> This variable identifies the number of differential states.

<diff0> This variable identifies the value of the first differential state.

<diff1, ... diff(n)> This variable identifies the value of the second and subsequent differential states.

Refer to the *E4428C/38C ESG Signal Generators Programming Guide* for more information on downloading and using files.

Example

```
:MEM:DATA:IQ "Test_BPSK",1,2,1,0,0,0
```

The preceding example loads and stores a two-symbol I/Q file named Test_BPSK that has a Q offset. The table shown below describes the command parameters.

- "Test_BPSK" Test_BPSK is the file name. The directory path is not needed. The path "/USER/IQ" is implied.
- 1 Q Offset. The Q output delay is enabled.
- 2 Number of symbols
- 1 Value of the first I symbol
- 0 Value of the first Q symbol.
- 0 Value of the second I symbol
- 0 Value of the second Q symbol

Memory Subsystem (:MEMory)

Range	<i>num_states</i> : 2–256 <i>i0–i(n)</i> : –1 to 1 <i>q0–q(n)</i> : –1 to 1 <i>num_diff_states</i> : 0–256 <i>diff0–diff(n)</i> : –128 to 127
Remarks	Refer to “File Name Variables” on page 13 for information on the file name syntax.

:DATA:PRAM:FILE:BLOCK

Supported E4438C with Option 001/601 or 002/602

`:MEMory:DATA:PRAM:FILE:BLOCK "<file_name>", <data_block>`

This command loads block-formatted data directly into pattern RAM volatile memory (WFM1). Pattern RAM memory describes how memory (WFM1) is used and is not a distinct piece of memory. A PRAM file is specified as an array of bytes.

"<file_name>" This variable names the destination file. No directory path name is needed.

<data_block> This parameter represents the data and file length parameters. The data in the file is represented by the <data_block> variable. The file length parameters are used by the signal generator for allocating memory.

Pattern Ram files are binary files downloaded directly into waveform memory as an array of bytes. Each byte specifies a data bit (LSB 0), a burst bit (BIT 2), and an Event 1 output bit (BIT 6). Refer to the *E4428C/38C ESG Signal Generators Programming Guide* for more information on pattern RAM downloading.

Example

`:MEM:DATA:PRAM:FILE:BLOC "PRAM_Data", #14Yq8L`

The preceding example downloads PRAM data to a file named PRAM_Data into the signal generator’s volatile memory (WFM1).

- "PRAM_Data" PRAM_Data is the file name. PRAM files are saved to the signal generator’s volatile memory (WFM1).
- #14Yq8L Data block
 - # This character indicates the beginning of the data block
 - 1 Number of digits in the byte count
 - 4 Byte count
 - Yq8L 4 bytes of data

NOTE The data, Yq8L, in the above command is not valid and is used for example purposes only. Typically, ASCII characters representing data are unprintable.

Remarks Refer to “File Name Variables” on page 13 for information on the file name syntax.

:DATA:PRAM:FILE:LIST

Supported E4438C with Option 001/601 or 002/602

MEMory:DATA:PRAM:FILE:LIST "<file_name>", <uint8>[, <uint8>, <...>]

This command loads list-formatted data directly into pattern RAM volatile memory (WFM1). Pattern RAM memory describes how memory (WFM1) is used and is not a distinct piece of memory. A PRAM file is specified as an array of bytes.

NOTE This command should be preceded by a *WAI (Wait-to-Continue) command to ensure that all pending operations are completed, before loading the list.

"<file_name>" This variable names the destination file.

<uint8> This variable is any of the valid 8-bit, unsigned integer values between 0 and 255.

[, <uint8>, <...>] This variable identifies the value of the second and subsequent 8-bit unsigned integer variables.

Pattern Ram files are binary files downloaded directly into waveform memory as an array of bytes. Each byte specifies a data bit (LSB 0), a burst bit (BIT 2), and an Event 1 output bit (BIT 6). Refer to the *E4428C/38C ESG Signal Generators Programming Guide* for more information on pattern RAM downloading.

Example

```
:MEM:DATA:PRAM:FILE:LIST "Pram_Data", 85,21,21,20,20,100
```

The preceding example downloads PRAM data, in list format, to a file named `Pram_Data` in the signal generator's volatile memory (WFM1).

- "Pram_Data" Pram_Data is the file name. PRAM files are saved to the signal generator's volatile memory (WFM1).
- 85 The first 8-bit integer value
- 21,21,20,20,100 Subsequent 8-bit integer values.

Memory Subsystem (:MEMory)

Range	0–255
Remarks	Refer to “File Name Variables” on page 13 for information on the file name syntax.

:DATA:PRAM

NOTE	Refer to the <i>E4428C/38C ESG Signal Generators Programming Compatibility Guide</i> for information on this command. This command is still valid for backward compatibility with earlier signal generator models.
-------------	--

:DATA:PRAM:BLOCK

NOTE	Refer to the <i>E4428C/38C ESG Signal Generators Programming Compatibility Guide</i> for information on this command. This command was replaced by “:DATA:PRAM:FILE:BLOCK” on page 112.
-------------	---

:DATA:PRAM:LIST

NOTE	Refer to the <i>E4428C/38C ESG Signal Generators Programming Compatibility Guide</i> for information on this command. This command has been replaced by “:DATA:PRAM:FILE:LIST” on page 113.
-------------	---

:DATA:SHAPE

Supported E4438C with Option 001/601 or 002/602

```
:MEMory:DATA:SHAPE "<filename>", <num_rise_points>, <rp0>, <rp1>,  
...<num_fall_points>, <fp0>, <fp1>, ...<fp(n)>  
:MEMory:DATA:SHAPE? "<filename>"
```

This command creates a new burst shape file and stores it in the signal generator non-volatile memory.

- "<filename>" This variable string identifies the name of the burst shape file.
- num_rise_points This variable specifies how many rise points used in the command.
- rp0,...rp(n) This variable defines each successive rise point, where 0 is no power and 1 is full power.
- num_fall_points This variable specifies how many fall points used in the command.

fp0,...fp(n) This variable defines each successive fall point, where 0 is no power and 1 is full power.

Range num_rise_points: 2–256 num_fall_points: 2–256
rp0–rp(n): 0.0–1.0 fp0–fp(n): 0.0–1.0

:DATA:SHAPE

Supported E4438C with Option 001/601 or 002/602

```
:MEMory:DATA:SHAPE
"<file_name>",<rise_pnts>,<rp0>,<rp1>,...<fall_points>,<fp0>,<fp1>,...<fp(n)>
:MEMory:DATA:SHAPE? "<file_name>"
```

This command loads a burst shape file into the signal generator's non-volatile memory (NVWFM).

"<file_name>" This variable names the destination file and directory path.

rise_pnts This variable indicates the number of rise points used to describe the burst shape rising slope.

rp0, . . . rp(n) This variable defines each successive rise point, where 0 is no power and 1 is full power.

fall_points This variable indicates the number of fall points used to describe the burst shape falling slope.

fp0, . . . fp(n) This variable defines each successive fall point, where 1 is full power and 0 is no power.

Refer the *E4428C/38C ESG Signal Generators Programming Guide* for more information on downloading and using files.

Example

```
:MEM:DATA:SHAP "Shape_File",6,0,0.2,0.4,0.6,0.8,1.0,2,0.5,0
```

The preceding example loads shape data to a file named `Shape_File` in the signal generator's non-volatile memory.

- "Shape_File" Shape_File is the shape data filename. The directory path is not needed. The path "/USER/SHAPE/" is implied.
- 6 Number of rise points describing the burst shape.
- 0,0.2,0.4,0.6,0.8,1.0 Rise point values.
- 2 Number of fall points describing the burst shape.
- 0.5,0 Fall point values.

Memory Subsystem (:MEMory)

Range *num_rise_points:* 2–256
 num_fall_points: 2–256
 rp0–rp(n): 0.0–1.0
 fp0–fp(n): 0.0–1.0

:DATA:UNPRotected

Supported E4438C with Option 001/601 or 002/602

:MEMory:DATA:UNPRotected "<file_name>",<data_block>

This command allows you to download data and store it in a file on the signal generator with the ability to retrieve it. This command is intended for downloading waveform data; however you can use it to download other types of data.

NOTE If you do not use the *UNPRotected* command when downloading a waveform file, you will not be able to retrieve or upload the file. Attempting to do so will cause the signal generator to display the message: `ERROR:221, Access denied`.

"<file_name>" This variable names the destination file and directory path. The file type determines how you must format the "<file_name>" variable as described in the following list.

- Binary file The "<file_name>" variable requires only a file name. A file name without a file path is automatically stored in the Binary memory catalog. Refer to [“File Name Variables” on page 13](#) for information on the file name syntax.
- Encrypted file The "<file_name>" variable requires a path that includes the SECUREWAVE directory. The securewave directory path is SNVWFM: for non-volatile waveform memory and SWFM1: for volatile waveform memory.
- All other file types The "<file_name>" variable requires a path that includes the destination directory for the file type. Refer to the [Table on page 14](#), and [“File Name Variables” on page 13](#) for more information.

<data_block> This parameter represents the data and file length parameters. The data in the file is represented by the <data_block> variable.

Refer to the *E4428C/38C ESG Signal Generators Programming Guide* for more information on downloading and using files.

Example

```
:MEM:DATA:UNPR "NVWFM:Data_File",#18Qz37pY9o
```

The preceding example downloads waveform data to a file named Data_File in the signal generator's non-volatile securewave directory. The table shown below describes the command parameters.

- | | |
|---------------------|--|
| • "NVWFM:Data_File" | Data_File is the filename. The directory path is not needed. The path "/USER/SECUREWAVE" is implied. |
| • #18Qz37pY9o | Data block |
| # | This character indicates the beginning of the data block |
| 1 | Number of digits in the byte count |
| 8 | Byte count |
| Qz37pY9o | 8 bytes of data |

NOTE The data, Qz37pY9o, in the above command is not valid and is used for example purposes only. Typically, ascii characters representing data are unprintable.

:DELeTe:ALL

Supported All Models

CAUTION Using this command deletes all user files including binary, list, state, and flatness correction files, and any saved setups which use the front panel table editor. However, this does not include files stored on the Option 001/601 or 002/602 baseband generator. You cannot recover the files after executing this command.

```
:MEMory:DELeTe:ALL
```

This command clears the file system of all user files.

Key Entry Delete All Files

Memory Subsystem (:MEMory)

:DELeTe:BINary

Supported E4438C with Option 001/601or 002/602

:MEMory:DELeTe:BINary

This command deletes all binary files.

Key Entry Delete All Binary Files

:DELeTe:BIT

Supported E4438C with Option 001/601or 002/602

:MEMory:DELeTe:BIT

This command deletes all bit files.

Key Entry Delete All Bit Files

:DELeTe:CDMa

NOTE Refer to the *E4428C/38C ESG Signal Generators Programming Compatibility Guide* for information on this command. This command is still valid for backward compatibility and was replaced by “:DELeTe:CDMA”.

:DELeTe:CDMA

Supported E4438C with Option 401

:MEMory:DELeTe:CDMA

This command deletes all arbitrary waveform IS-95 CDMA files.

Key Entry Delete All ARB CDMA Files

:DELeTe:DMOD

Supported E4438C with Option 001/601or 002/602

:MEMory:DELeTe:DMOD

This command deletes all arbitrary waveform digital modulation files.

Key Entry Delete All ARB DMOD Files

:DElete:DWCDma

Supported E4438C with Option 400

:MEMory:DElete:DWCDma

This command deletes all arbitrary waveform downlink W-CDMA files.

Key Entry Delete All ARB DWCDMA Files

:DElete:FCDMa

Supported E4438C with Option 401

:MEMory:DElete:FCDMa

This command deletes all arbitrary waveform forward link W-CDMA files.

Key Entry Delete All ARB FCDMA Files

:DElete:FIR

Supported E4438C with Option 001/601 or 002/602

:MEMory:DElete:FIR

This command deletes all finite impulse response filter files.

Key Entry Delete All FIR Files

:DElete:FSK

Supported E4438C with Option 001/601 or 002/602

:MEMory:DElete:FSK

This command deletes all FSK files.

Key Entry Delete All FSK Files

:DElete:IQ

Supported E4438C with Option 001/601 or 002/602

:MEMory:DElete:IQ

This command deletes all I/Q files.

Key Entry Delete All I/Q Files

Memory Subsystem (:MEMory)

:DElete:LIST

Supported All Models

:MEMory:DElete:LIST

This command deletes all List files.

Key Entry Delete All List Files

:DElete:MCDMa

Supported E4438C with Option 401

:MEMory:DElete:MCDMa

This command deletes all arbitrary waveform multicarrier IS-95 CDMA files.

Key Entry Delete All ARB MCDMA Files

:DElete:MDMod

Supported E4438C with Option 001/601 or 002/602

:MEMory:DElete:MDMod

This command deletes all arbitrary waveform multicarrier digital modulation files.

Key Entry Delete All ARB MDMOD Files

:DElete:MDWCdma

Supported E4438C with Option 400

:MEMory:DElete:MDWCdma

This command deletes all arbitrary waveform multicarrier downlink W-CDMA files.

Key Entry Delete All ARB MDWCDMA Files

:DElete:MFCdma

Supported E4438C with Option 401

:MEMory:DElete:MFCdma

This command deletes all arbitrary waveform multicarrier forward link cdma2000 files.

Key Entry Delete All ARB MFCDMA Files

:DELeTe:MTONE

Supported E4438C with Option 001/601 or 002/602

:MEMory:DELeTe:MTONE

This command deletes all arbitrary waveform multitone files.

Key Entry Delete All ARB MTONE Files

:DELeTe:RCDMa

Supported E4438C with Option 401

:MEMory:DELeTe:RCDMa

This command deletes all arbitrary waveform reverse link cdma2000 files.

Key Entry Delete All ARB RCDMA Files

:DELeTe:SEQ

Supported E4438C with Option 001/601 or 002/602

:MEMory:DELeTe:SEQ

This command deletes all sequence files.

Key Entry Delete All Sequence Files

:DELeTe:SHAPE

Supported E4438C with Option 001/601 or 002/602

:MEMory:DELeTe:SHAPE

This command deletes all burst shape files.

Key Entry Delete All Shape Files

:DELeTe:STATe

Supported All Models

:MEMory:DELeTe:STATe

This command deletes all state files.

Key Entry Delete All Models State Files

Memory Subsystem (:MEMory)

:DELeTe:UFLT

Supported All Models

:MEMory:DELeTe:UFLT

This command deletes all user-flatness correction files.

Key Entry Delete All UFLT Files

:DELeTe:UWCDma

Supported E4438C with Option 400

:MEMory:DELeTe:UWCDma

This command deletes all arbitrary waveform uplink W-CDMA files.

Key Entry Delete All ARB UWCDMA Files

:DELeTe[:NAME]

Supported All Models

:MEMory:DELeTe[:NAME] "<file name>"

This command clears the user file system of "<file name>".

Key Entry Delete File

Remarks Refer to [“File Name Variables” on page 13](#) for information on the file name syntax.

When deleting a waveform (WFM1) file from memory, the marker file and file header, associated with the waveform file, will also be deleted.

:FREE[:ALL]

Supported All Models

:MEMory:FREE[:ALL] ?

This command returns the number of bytes left in the user file system.

Key Entry All

:LOAD:LIST

Supported All Models

```
:MEMory:LOAD:LIST "<file name>"
```

This command loads a list sweep file.

Key Entry Load From Selected File

:MOVE

Supported All Models

```
:MEMory:MOVE "<src_file>","<dest_file>"
```

This command renames the requested file in the memory catalog.

Key Entry Rename File

Remarks Refer to [“File Name Variables” on page 13](#) for information on the file name syntax.

:STATe:COMMENT

Supported All Models

```
:MEMory:STATe:COMMENT <reg_num>,<seq_num>,"<comment>"
```

```
:MEMory:STATe:COMMENT? <reg_num>,<seq_num>
```

This command lets you to add a descriptive comment to the saved state <reg_num>,<seq_num>. Comments can be up to 55 characters long.

Key Entry Add Comment To Seq[n] Reg[nn]

:STORe:LIST

Supported All Models

```
:MEMory:STORe:LIST "<file name>"
```

This command stores the current list sweep data to a file.

Key Entry Store To File

Mass Memory Subsystem (:MMEMory)

:CATalog

Supported All Models

```
:MMEMory:CATalog? "<msus>"
```

This command outputs a list of the files from the specified file system.

The variable "<msus>" (mass storage unit specifier) represents "<file system>". The file systems and types are shown in [Table 1-4 on page 14](#).

The return data will be in the following form:

```
<mem used>,<mem free>{,"<file listing>"}
```

The signal generator will return the two memory usage parameters and as many file listings as there are files in the specified file system. Each file listing will be in the following format:

```
"<file name,file type,file size>"
```

Key Entry	Binary	List	State	User Flatness	FIR	Shape	Bit	FSK
	IQ	Seq	DMOD	MTONE	MDMOD	CDMA	MCDMA	FCDM
								A
	MFCDMA	RCDMA	WCDMA	FWCDMA	MFWCDMA	RWCDM		A
	DWCDMA	MDWCDMA	UWCDMA	WFM1	NVMKR	NVWF		M

Remarks Refer to “[MSUS \(Mass Storage Unit Specifier\) Variable](#)” on page 16 for information on the use of the "<msus>" variable.

:COPY

Supported All Models

```
:MMEMory:COPY "<file name>","<file name>"
```

This command makes a duplicate of the requested file.

Key Entry Copy File

Remarks Refer to “[File Name Variables](#)” on page 13 for information on the file name syntax.

When copying a waveform file from volatile to non-volatile memory, the marker

file and file header, associated with the waveform file, will automatically be copied at the same time.

:DATA

Supported E4438C with Option 001/601or 002/602

:MMEMory:DATA "<file name>",<datablock>

:MMEMory:DATA? "<file name>"

This command loads <datablock> into the memory location "<file name>".

The query returns the <datablock> associated with the "<file name>".

Remarks Refer to [“File Name Variables” on page 13](#) for information on the file name syntax.

:DElete:NVWFm

Supported E4438C with Option 001/601or 002/602

:MMEMory:DElete:NVWFm

This command clears the user file system of all non-volatile arbitrary waveform files.

Key Entry Delete All NVWFM Files

:DElete:WFM

Supported E4438C with Option 001/601or 002/602

:MMEMory:DElete:WFM

This command clears the user file system of all arbitrary waveform files, which is the same function as performed by the command shown in [“:DElete:WFM1”](#).

Key Entry Delete All WFM1 Files

:DElete:WFM1

Supported E4438C with Option 001/601or 002/602

:MMEMory:DElete:WFM1

This command clears the user file system of all arbitrary waveform files, which is the same function as performed by the command shown in [“:DElete:WFM”](#).

Key Entry Delete All WFM1 Files

Mass Memory Subsystem (:MMEMory)

:DELEte[:NAME]

Supported All

`:MMEMory:DELEte[:NAME] "<file name>", ["<msus>"]`

This command clears the user file system of "<file name>" with the option of specifying the file system separately.

The variable "<msus>" (mass storage unit specifier) represents the file system. For a list of the file systems refer to the [Table on page 14](#).

Key Entry Delete File

Remarks If the optional variable "<msus>" is omitted, the file name needs to include the file system extension. Refer to [“File Name Variables” on page 13](#) and [“MSUS \(Mass Storage Unit Specifier\) Variable” on page 16](#) for information on the use of the file variables.

When deleting a waveform file from memory, the marker file and file header, associated with the waveform file, will also be deleted.

:HEADer:CLEar

Supported E4438C with Option 001/601or 002/602

`:MMEMory:HEADer:CLEar "<file name>"`

This command sets the file header field settings to unspecified for the "<file name>" variable.

Key Entry Clear Header

Remarks This command does not require a personality modulation to be on. Refer to [“File Name Variables” on page 13](#) for information on the file name syntax.

:HEADer:DESCription

Supported E4438C with Option 001/601or 002/602

`:MMEMory:HEADer:DESCription "<file name>","<description>"`

`:MMEMory:HEADer:DESCription? "<file name>"`

This command inserts a description for the file header.

Key Entry Edit Description

Remarks The header description is limited to 32 characters. Refer to [“File Name Variables” on page 13](#) for information on the file name syntax.

:LOAD:LIST

Supported All

:MMEMory:LOAD:LIST "<file name>"

This command loads a List sweep file.

Key Entry Load From Selected File

:MOVE

Supported All

:MMEMory:MOVE "<src_file>","<dest_file>"

This command renames the requested file in the memory catalog.

Key Entry Rename File

Remarks Refer to [“File Name Variables” on page 13](#) for information on the file name syntax.

:STORE:LIST

Supported All

:MMEMory:STORE:LIST "<file name>"

This command stores the current list sweep data to a file.

Key Entry Store To File

Output Subsystem (:OUTPut)

:BLANking:AUTO

Supported All

:OUTPut:BLANking:AUTO ON|OFF|1|0

:OUTPut:BLANking:AUTO?

This command turns the RF output on or off during frequency band changes. Frequency band changes can cause the signal generator's RF output to fluctuate. The output blanking function, when active, turns off the RF output until the frequency settles.

ON (1) The RF output turns off when crossing a frequency band.

OFF (0) The RF output stays on when crossing a frequency band.

***RST** 1

Key Entry Output Blanking Off On Auto

Remarks Refer to the signal generator's data sheet for information on frequency switching speeds, settling times, and frequency band information.

:BLANking:STATe

Supported All

:OUTPut:BLANking:STATe ON|OFF|1|0

:OUTPut:BLANking:STATe?

This command enables or disables the RF output blanking state.

ON (1) The RF output turns off during frequency changes.

OFF (0) The RF output stays on during frequency changes.

***RST** 1

Remarks Refer to the signal generator's data sheet for information on frequency switching speeds, settling times, and frequency band information.

:MODulation[:STATe]

Supported All

:OUTPut:MODulation[:STATe] ON|OFF|1|0

:OUTPut:MODulation[:STATe]?

This command enables or disables the modulation of the RF output with the currently active modulation type(s).

***RST** 1

Key Entry Mod On/Off

Remarks Some modulation types can be simultaneously enabled such as pulse and AM.
An annunciator on the signal generator is always displayed to indicate whether modulation is switched on or off.

[:STATe]

Supported All

:OUTPut[:STATe] ON|OFF|1|0

:OUTPut[:STATe]?

This command enables or disables the RF output.

***RST** 0

Key Entry RF On/Off

Remarks Although you can configure and engage various modulations, no signal is available at the RF OUTPUT connector until this command is executed.
An annunciator is always displayed on the signal generator to indicate whether the RF output is switched on or off.

Route Subsystem (:ROUTE:HARDware:DGENERator)

:INPut:BPOLarity

Supported E4438C with Option 001/601 or 002/602

:ROUTE:HARDware:DGENERator:INPut:BPOLarity POSitive|NEGative

:ROUTE:HARDware:DGENERator:INPut:BPOLarity?

This command configures the polarity of the TTL input signal at the BURST GATE IN connector. POSitive refers to normal logic, while NEGative refers to inverted logic.

***RST** POS

Key Entry Burst Gate In Polarity Neg Pos

Remarks This command performs the same function as “:IPOLarity:BGATE” on page 131.

:INPut:CPOLarity

Supported E4438C with Option 001/601 or 002/602

:ROUTE:HARDware:DGENERator:INPut:CPOLarity POSitive|NEGative

:ROUTE:HARDware:DGENERator:INPut:CPOLarity?

This command configures the polarity of the TTL input signal at the DATA CLOCK connector. POSitive refers to normal logic, while NEGative refers to inverted logic.

***RST** POS

Key Entry Data Clock Polarity Neg Pos

Remarks This command performs the same function as “:IPOLarity:CLOCK” on page 132.

:INPut:DPOLarity

Supported E4438C with Option 001/601or 002/602

:ROUTE:HARDware:DGENERator:INPut:DPOLarity POSitive|NEGative

:ROUTE:HARDware:DGENERator:INPut:DPOLarity?

This command configures the polarity of the TTL input signal at the DATA connector. POSitive refers to normal logic, while NEGative refers to inverted logic.

***RST** POS

Key Entry Data Polarity Neg Pos

Remarks This command performs the same function as “:IPOLarity:DATA” on page 132.

:INPut:SPOLarity

Supported E4438C with Option 001/601or 002/602

:ROUTE:HARDware:DGENERator:INPut:SPOLarity POSitive|NEGative

:ROUTE:HARDware:DGENERator:INPut:SPOLarity?

This command configures the polarity of the TTL input signal at the SYMBOL SYNC connector. POSitive refers to normal logic, while NEGative refers to inverted logic.

***RST** POS

Key Entry Symbol Sync Polarity Neg Pos

Remarks This command performs the same function as “:IPOLarity:SSYNc” on page 132.

:IPOLarity:BGATE

Supported E4438C with Option 001/601or 002/602

:ROUTE:HARDware:DGENERator:IPOLarity:BGATE POSitive|NEGative

:ROUTE:HARDware:DGENERator:IPOLarity:BGATE?

This command configures the polarity of the input signal at the BURST GATE IN connector. POSitive refers to normal logic, while NEGative refers to inverted logic.

***RST** POS

Key Entry Burst Gate In Polarity Neg Pos

Remarks This command performs the same function as “:INPut:BPOLarity” on page 130.

:IPOLarity:CLOCK

Supported E4438C with Option 001/601or 002/602

:ROUTE:HARDware:DGENERator:IPOLarity:CLOCK POSitive|NEGative

:ROUTE:HARDware:DGENERator:IPOLarity:CLOCK?

This command configures the polarity of the TTL input signal at the DATA CLOCK connector. POSitive refers to normal logic, while NEGative refers to inverted logic.

***RST** POS

Key Entry Data Clock Polarity Neg Pos

Remarks This command performs the same function as “:INPut:CPOlarity” on page 130.

:IPOLarity:DATA

Supported E4438C with Option 001/601or 002/602

:ROUTE:HARDware:DGENERator:IPOLarity:DATA POSitive|NEGative

:ROUTE:HARDware:DGENERator:IPOLarity:DATA?

This command configures the polarity of the TTL input signal at the DATA connector. POSitive refers to normal logic, while NEGative refers the inverted logic.

***RST** POS

Key Entry Data Polarity Neg Pos

Remarks This command performs the same function as “:INPut:DPOlarity” on page 131.

:IPOLarity:SSYNc

Supported E4438C with Option 001/601or 002/602

:ROUTE:HARDware:DGENERator:IPOLarity:SSYNc POSitive|NEGative

:ROUTE:HARDware:DGENERator:IPOLarity:SSYNc?

This command configures the polarity of the TTL input signal at the SYMBOL SYNC connector. POSitive refers to normal logic, while NEGative refers to inverted logic.

***RST** POS

Key Entry Symbol Sync Polarity Neg Pos

Remarks This command performs the same function as “:INPut:SPOlarity” on page 131.

:OPOLarity:CLOCK

Supported E4438C with Option 001/601or 002/602

:ROUTE:HARDware:DGENERator:OPOLarity:CLOCK POSitive|NEGative

:ROUTE:HARDware:DGENERator:OPOLarity:CLOCK?

This command configures the polarity of the TTL output Data Clock Out signal at the DATA CLK OUT pin on the rear panel AUX I/O connector. POSitive refers to normal logic, while the NEGative refers to inverted logic.

***RST** POS

Key Entry Data Clock Out Neg Pos

Remarks This command performs the same function as “:OUTPut:CPOLarity” on [page 134](#).

:OPOLarity:DATA

Supported E4438C with Option 001/601or 002/602

:ROUTE:HARDware:DGENERator:OPOLarity:DATA POSitive|NEGative

:ROUTE:HARDware:DGENERator:OPOLarity:DATA?

This command configures the polarity of the TTL output DATA OUT signal at the DATA OUT pin on the rear panel AUX I/O connector. POSitive refers to normal logic, while NEGative refers to inverted logic.

***RST** POS

Key Entry Data Out Polarity Neg Pos

Remarks This command performs the same function as “:OUTPut:DPOLarity” on [page 135](#).

Route Subsystem (:ROUTE:HARDware:DGENERator)

:OPOLarity:SSYNc

Supported E4438C with Option 001/601or 002/602

:ROUTE:HARDware:DGENERator:OPOLarity:SSYNc POSitive|NEGative

:ROUTE:HARDware:DGENERator:OPOLarity:SSYNc?

This command configures the polarity of the TTL output SYMBOL SYNC signal at the SYM SYNC OUT pin on the rear panel AUX I/O connector. POSitive refers to normal logic, while NEGative refers to inverted logic.

***RST** POS

Key Entry Symbol Sync Out Polarity Neg Pos

Remarks This command performs the same function as “:OUTPut:SPOLarity” on [page 135](#).

:OUTPut:CPOLarity

Supported E4438C with Option 001/601or 002/602

:ROUTE:HARDware:DGENERator:OUTPut:CPOLarity POSitive|NEGative

:ROUTE:HARDware:DGENERator:OUTPut:CPOLarity?

This command configures the polarity of the TTL output DATA CLOCK OUT signal at the DATA CLK OUT pin on the rear panel AUX I/O connector. POSitive refers to normal logic, while NEGative refers to inverted logic.

***RST** POS

Key Entry Data Clock Polarity Neg Pos

Remarks This command performs the same function as “:OPOLarity:CLOCK” on [page 133](#).

:OUTPut:DCS[:STATe]

Supported E4438C with Option 001/601or 002/602

```
:ROUTE:HARDware:DGENERator:OUTPut:DCS[:STATe] ON|OFF|1|0
```

```
:ROUTE:HARDware:DGENERator:OUTPut:DCS[:STATe] ?
```

This command is used to enable or disable the output DATA OUT, DATA CLK OUT, and SYM SYNC OUT signals from the rear panel AUX I/O connector. Normally, these output signals should be enabled (On). However, disabling these outputs will decrease the spurs that are sometimes present when operating at high symbol rates.

***RST** 1

Key Entry DATA/CLK/SYNC Rear Outputs Off On

:OUTPut:DPOLarity

Supported E4438C with Option 001/601or 002/602

```
:ROUTE:HARDware:DGENERator:OUTPut:DPOLarity POSitive|NEGative
```

```
:ROUTE:HARDware:DGENERator:OUTPut:DPOLarity?
```

This command configures the polarity of the TTL output signal at the DATA OUT connector. POSitive refers to normal logic, while NEGative refers to inverted logic.

***RST** POS

Key Entry Data Out Polarity Neg Pos

Remarks This command performs the same function as “:OPOLarity:DATA” on page 133.

:OUTPut:SPOLarity

Supported E4438C with Option 001/601or 002/602

```
:ROUTE:HARDware:DGENERator:OUTPut:SPOLarity POSitive|NEGative
```

```
:ROUTE:HARDware:DGENERator:OUTPut:SPOLarity?
```

This command configures the polarity of the TTL input signal at the SYMBOL SYNC connector. POSitive refers to normal logic, while NEGative refers to inverted logic.

***RST** POS

Key Entry Symbol Sync Out Polarity Neg Pos

Status Subsystem (:STATus)

:OPERation:BASEband:CONDition

Supported E4438C with Option 001/601 or 002/602

:STATus:OPERation:BASEband:CONDition?

This query returns the decimal sum of the bits in the Baseband Operation Condition Register. For example, if the baseband is busy (bit 0), the value 1 is returned.

Range 0–32767

Remarks The data in this register is continuously updated and reflects the current conditions.

Refer to Chapter 3 of the *E4428C/38C ESG Signal Generators Programming Guide* for more information.

:OPERation:BASEband:ENABLE

Supported E4438C with Option 001/601 or 002/602

:STATus:OPERation:BASEband:ENABLE <val>

:STATus:OPERation:BASEband:ENABLE?

This command determines which bits in the Baseband Operation Event Register will set the Baseband is Busy bit (bit 10) in the Standard Operation Condition Register.

The variable <num> is the sum of the decimal values of the bits you want to enable.

Range 0–32767

Remarks Refer to Chapter 3 of the *E4428C/38C ESG Signal Generators Programming Guide* for more information.

:OPERation:BASEband:NTRansition

Supported E4438C with Option 001/601 or 002/602

:STATUs:OPERation:BASEband:NTRansition <val>

:STATUs:OPERation:BASEband:NTRansition?

This command determines which bits in the Baseband Operation Condition Register will set the corresponding bit in the Baseband Operation Event Register when that bit has a negative transition (1 to 0).

The variable <val> is the sum of the decimal values of the bits that you want to enable.

Range 0–32767

Remarks Refer to Chapter 3 of the *E4428C/38C ESG Signal Generators Programming Guide* for more information.

:OPERation:BASEband:PTRansition

Supported E4438C with Option 001/601 or 002/602

:STATUs:OPERation:BASEband:PTRansition <val>

:STATUs:OPERation:BASEband:PTRansition?

This command determines which bits in the Baseband Operation Condition Register will set the corresponding bit in the Baseband Operation Event Register when that bit has a positive transition (0 to 1).

The variable <val> is the sum of the decimal values of the bits that you want to enable.

Range 0–32767

Remarks Refer to Chapter 3 of the *E4428C/38C ESG Signal Generators Programming Guide* for more information.

:OPERation:BASEband[:EVENT]

Supported E4438C with Option 001/601 or 002/602

:STATUS:OPERation:BASEband[:EVENT]?

CAUTION This is a destructive read. The data in the register is latched until it is queried. Once queried, the data is cleared.

This query returns the decimal sum of the bits in the Standard Operation Baseband Event Register.

Range 0–32767

Remarks The equivalent PTR and NTR filters must be set before the condition register can set the corresponding bit in the event register.

Refer to Chapter 3 of the *E4428C/38C ESG Signal Generators Programming Guide* for more information.

:OPERation:CONDition

Supported All

:STATUS:OPERation:CONDition?

This query returns the decimal sum of the bits for the registers that are set to one and are part of the Standard Operation Status Group. For example, if a sweep is in progress (bit 3), the value 8 is returned.

Range 0–32767

Remarks The data in this register is continuously updated and reflects current conditions.

Refer to Chapter 3 of the *E4428C/38C ESG Signal Generators Programming Guide* for more information.

:OPERation:ENABle

Supported All

:STATus:OPERation:ENABle <val>

:STATus:OPERation:ENABle?

This command determines which bits in the Standard Operation Event Register will set the Standard Operation Status Summary bit (bit 7) in the Status Byte Register.

The variable <val> is the sum of the decimal values of the bits that you want to enable.

Range 0–32767

Remarks Refer to Chapter 3 of the *E4428C/38C ESG Signal Generators Programming Guide* for more information.

:OPERation:NTRansition

Supported All

:STATus:OPERation:NTRansition <val>

:STATus:OPERation:NTRansition?

This command determines which bits in the Standard Operation Condition Register will set the corresponding bit in the Standard Operation Event Register when that bit has a negative transition (1 to 0).

The variable <val> is the sum of the decimal values of the bits that you want to enable.

Range 0–32767

Remarks Refer to Chapter 3 of the *E4428C/38C ESG Signal Generators Programming Guide* for more information.

:OPERation:PTRansition

Supported All

:STATUS:OPERation:PTRansition <val>

:STATUS:OPERation:PTRansition?

This command determines which bits in the Standard Operation Condition Register will set the corresponding bit in the Standard Operation Event Register when that bit has a positive transition (0 to 1).

The variable <val> is the sum of the decimal values of the bits that you want to enable.

Range 0–32767

Remarks Refer to Chapter 3 of the *E4428C/38C ESG Signal Generators Programming Guide* for more information.

:OPERation[:EVENT]

Supported All

CAUTION This is a destructive read. The data in the register is latched until it is queried. Once queried, the data is cleared.

:STATUS:OPERation[:EVENT]?

This query returns the decimal sum of the bits in the Standard Operation Event Register.

Range 0–32767

Remarks The equivalent PTR or NTR filters must be set before the condition register can set the corresponding bit in the event register.

Refer to Chapter 3 of the *E4428C/38C ESG Signal Generators Programming Guide* for more information.

:PRESet

Supported All

:STATUS:PRESet

This command presets all transition filters, enable registers, and error/event queue enable registers.

Remarks Refer to Chapter 3 of the *E4428C/38C ESG Signal Generators Programming Guide* for more information.

:QUESTIONable:BERT:CONDition

Supported E4438C with Option UN7, 300 or both

`:STATUS:QUESTIONable:BERT:CONDition?`

This query returns the decimal sum of the bits in the Data Questionable BERT Condition Register. For example, if no clock signal has been input for more than three seconds during the bit error rate measurement (bit 0), then a value of 1 is returned.

Range 0–32767

Remarks The data in this register is continuously updated and reflects the current conditions.

Refer to Chapter 3 of the *E4428C/38C ESG Signal Generators Programming Guide* for more information.

:QUESTIONable:BERT:ENABLE

Supported E4438C with Option UN7, 300 or both

`:STATUS:QUESTIONable:BERT:ENABLE <val>`

`:STATUS:QUESTIONable:BERT:ENABLE?`

This command determines which bits in the Data Questionable BERT Event Register will set the Data Questionable BERT Summary bit (bit 12) in the Data Questionable Condition Register.

The variable <val> is the sum of the decimal values of the bits you want to enable.

Range 0–32767

Remarks Refer to Chapter 3 of the *E4428C/38C ESG Signal Generators Programming Guide* for more information.

:QUESTionable:BERT:NTRansition

Supported E4438C with Option UN7, 300 or both

:STATus:QUESTionable:BERT:NTRansition <val>

:STATus:QUESTionable:BERT:NTRansition?

This command determines which bits in the Data Questionable BERT Condition Register will set the corresponding bit in the Data Questionable BERT Event Register when that bit has a negative transition (1 to 0).

The variable <val> is the sum of the decimal values of the bits that you want to enable.

Range 0–32767

Remarks The data in this register is continuously updated and reflects the current conditions.

Refer to Chapter 3 of the *E4428C/38C ESG Signal Generators Programming Guide* for more information.

:QUESTionable:BERT:PTRansition

Supported E4438C with Option UN7, 300 or both

:STATus:QUESTionable:BERT:PTRansition <val>

:STATus:QUESTionable:BERT:PTRansition?

This command determines which bits in the Data Questionable BERT Condition Register will set the corresponding bit in the Data Questionable BERT Event Register when that bit has a positive transition (0 to 1).

The variable <val> is the sum of the decimal values of the bits that you want to enable.

Range 0–32767

Remarks Refer to Chapter 3 of the *E4428C/38C ESG Signal Generators Programming Guide* for more information.

:QUESTionable:BERT[:EVENT]

Supported E4438C with Option UN7, 300 or both

CAUTION This is a destructive read. The data in the register is latched until it is queried. Once queried, the data is cleared.

:STATus:QUESTionable:BERT[:EVENT]?

This command returns the decimal value of the sum of the bits in the Data Questionable BERT Event Register.

Range 0–32767

Remarks Note that the register requires that the equivalent PTR or NTR filters be set before a condition register bit can set a bit in the Event register.

Refer to Chapter 3 of the *E4428C/38C ESG Signal Generators Programming Guide* for more information.

:QUESTionable:CALibration:CONDition

Supported All

:STATus:QUESTionable:CALibration:CONDition?

This query returns the decimal sum of the bits in the Data Questionable Calibration Condition Register. For example, if the DCFM or DCΦM zero calibration fails (bit 0), a value of 1 is returned.

Range 0–32767

Remarks The data in this register is continuously updated and reflects the current conditions.

Refer to Chapter 3 of the *E4428C/38C ESG Signal Generators Programming Guide* for more information.

:QUESTionable:CALibration:ENABLE

Supported All

:STATus:QUESTionable:CALibration:ENABLE <val>

:STATus:QUESTionable:CALibration:ENABLE?

This command determines which bits in the Data Questionable Calibration Event Register will set the calibration summary bit (bit 8) in the Data Questionable Condition Register.

Status Subsystem (:STATus)

The variable <val> is the sum of the decimal values of the bits that you want to enable.

Range 0–32767

Remarks Refer to Chapter 3 of the *E4428C/38C ESG Signal Generators Programming Guide* for more information.

:QUESTionable:CALibration:NTRansition

Supported All

```
:STATus:QUESTionable:CALibration:NTRansition <val>  
:STATus:QUESTionable:CALibration:NTRansition?
```

This command determines which bits in the Data Questionable Calibration Condition Register will set the corresponding bit in the Data Questionable Calibration Event Register when that bit has a negative transition (1 to 0).

The variable <val> is the sum of the decimal values of the bits that you want to enable.

Range 0–32767

Remarks Refer to Chapter 3 of the *E4428C/38C ESG Signal Generators Programming Guide* for more information.

:QUESTionable:CALibration:PTRansition

Supported All

```
:STATus:QUESTionable:CALibration:PTRansition <val>  
:STATus:QUESTionable:CALibration:PTRansition?
```

This command determines which bits in the Data Questionable Calibration Condition Register will set the corresponding bit in the Data Questionable Calibration Event Register when that bit has a positive transition (0 to 1).

The variable <val> is the sum of the decimal values of the bits that you want to enable.

Range 0–32767

Remarks Refer to Chapter 3 of the *E4428C/38C ESG Signal Generators Programming Guide* for more information.

:QUEStionable:CALibration[:EVENT]

Supported All

CAUTION This is a destructive read. The data in the register is latched until it is queried. Once queried, the data is cleared.

:STATus:QUEStionable:CALibration[:EVENT]?

This command returns the decimal sum of the bits in the Data Questionable Calibration Event Register.

Range 0–32767

Remarks The equivalent PTR or NTR filters must be set before the condition register can set the corresponding bit in the event register.

Refer to Chapter 3 of the *E4428C/38C ESG Signal Generators Programming Guide* for more information.

:QUEStionable:CONDition

Supported All

:STATus:QUEStionable:CONDition?

This query returns the decimal sum of the bits in the Data Questionable Condition Register. For example, if the reference oscillator oven is cold (bit 4), a value of 16 is returned.

Range 0–32767

Remarks The data in this register is continuously updated and reflects current conditions.

Refer to Chapter 3 of the *E4428C/38C ESG Signal Generators Programming Guide* for more information.

:QUESTionable:ENABle

Supported All

:STATus:QUESTionable:ENABle <val>

:STATus:QUESTionable:ENABle?

This command determines which bits in the Data Questionable Event Register will set the Data Questionable Status Group Summary bit (bit 3) in the Status Byte Register.

The variable <val> is the sum of the decimal values of the bits that you want to enable.

Range 0–32767

Remarks Refer to Chapter 3 of the *E4428C/38C ESG Signal Generators Programming Guide* for more information.

:QUESTionable:FREQuency:CONDition

Supported All

:STATus:QUESTionable:FREQuency:CONDition?

This query returns the decimal sum of the bits in the Data Questionable Frequency Condition Register. For example, if the 1 GHz internal reference clock is unlocked (bit 2), a value of 4 is returned.

Range 0–32767

Remarks The data in this register is continuously updated and reflects current conditions.
Refer to Chapter 3 of the *E4428C/38C ESG Signal Generators Programming Guide* for more information.

:QUESTionable:FREQuency:ENABle

Supported All

:STATus:QUESTionable:FREQuency:ENABle <val>

:STATus:QUESTionable:FREQuency:ENABle?

This command determines which bits in the Data Questionable Frequency Event Register will set the frequency summary bit (bit 5) in the Data Questionable Condition Register.

The variable <val> is the sum of the decimal values of the bits that you want to enable.

Range 0–32767

Remarks Refer to Chapter 3 of the *E4428C/38C ESG Signal Generators Programming Guide* for more information.

:QUESTionable:FREQuency:NTRansition

Supported All

```
:STATUS:QUESTionable:FREQuency:NTRansition <val>  
:STATUS:QUESTionable:FREQuency:NTRansition?
```

This command determines which bits in the Data Questionable Frequency Condition Register will set the corresponding bit in the Data Questionable Frequency Event Register when that bit has a negative transition (1 to 0).

The variable <val> is the sum of the decimal values of the bits that you want to enable.

Range 0–32767

Remarks Refer to Chapter 3 of the *E4428C/38C ESG Signal Generators Programming Guide* for more information.

:QUESTionable:FREQuency:PTRansition

Supported All

```
:STATUS:QUESTionable:FREQuency:PTRansition <val>  
:STATUS:QUESTionable:FREQuency:PTRansition?
```

This command determines which bits in the Data Questionable Frequency Condition Register will set the corresponding bit in the Data Questionable Frequency Event Register when that bit has a positive transition (0 to 1).

The variable <val> is the sum of the decimal values of the bits that you want to enable.

Range 0–32767

Remarks Refer to Chapter 3 of the *E4428C/38C ESG Signal Generators Programming Guide* for more information.

:QUESTionable:FREQuency[:EVENT]

Supported All

CAUTION This is a destructive read. The data in the register is latched until it is queried. Once queried, the data is cleared.

```
:STATUS:QUESTionable:FREQuency[:EVENT]?
```

This query returns the decimal sum of the bits in the Data Questionable Frequency Event Register.

Range 0–32767

Status Subsystem (:STATus)

Remarks The equivalent PTR or NTR filters must be set before the condition register can set the corresponding bit in the event register.

Refer to Chapter 3 of the *E4428C/38C ESG Signal Generators Programming Guide* for more information.

:QUESTionable:MODulation:CONDition

Supported All

:STATus:QUESTionable:MODulation:CONDition?

This command returns the decimal sum of the bits in the Data Questionable Modulation Condition Register. For example, if the modulation is uncalibrated (bit 4), a value of 16 is returned.

Range 0–32767

Remarks The data in this register is continuously updated and reflects current conditions.

Refer to Chapter 3 of the *E4428C/38C ESG Signal Generators Programming Guide* for more information.

:QUESTionable:MODulation:ENABLE

Supported All

:STATus:QUESTionable:MODulation:ENABLE <val>

:STATus:QUESTionable:MODulation:ENABLE?

This command determines which bits in the Data Questionable Modulation Event Register will set the modulation summary bit (bit 7) in the Data Questionable Condition Register.

The variable <val> is the sum of the decimal values of the bits that you want to enable.

Range 0–32767

Remarks Refer to Chapter 3 of the *E4428C/38C ESG Signal Generators Programming Guide* for more information.

:QUESTionable:MODulation:NTRansition

Supported All

```
:STATUS:QUESTionable:MODulation:NTRansition <val>  
:STATUS:QUESTionable:MODulation:NTRansition?
```

This command determines which bits in the Data Questionable Modulation Condition Register will set the corresponding bit in the Data Questionable Modulation Event Register when that bit has a negative transition (1 to 0).

The variable <val> is the sum of the decimal values of the bits that you want to enable.

Range 0–32767

Remarks Refer to Chapter 3 of the *E4428C/38C ESG Signal Generators Programming Guide* for more information.

:QUESTionable:MODulation:PTRansition

Supported All

```
:STATUS:QUESTionable:MODulation:PTRansition <val>  
:STATUS:QUESTionable:MODulation:PTRansition?
```

This command determines which bits in the Data Questionable Modulation Condition Register will set the corresponding bit in the Data Questionable Modulation Event Register when that bit has a positive transition (0 to 1).

The variable <val> is the sum of the decimal values of the bits that you want to enable.

Range 0–32767

Remarks Refer to Chapter 3 of the *E4428C/38C ESG Signal Generators Programming Guide* for more information.

:QUESTionable:MODulation[:EVENT]

Supported All

CAUTION This is a destructive read. The data in the register is latched until it is queried. Once queried, the data is cleared.

```
:STATUS:QUESTionable:MODulation[:EVENT]?
```

This query returns the decimal sum of the bits in the Data Questionable Modulation Event Register.

Range 0–32767

Status Subsystem (:STATus)

Remarks The equivalent PTR or NTR filters must be set before the condition register can set the corresponding bit in the event register.

Refer to Chapter 3 of the *E4428C/38C ESG Signal Generators Programming Guide* for more information.

:QUEStionable:NTRansition

Supported All

```
:STATus:QUEStionable:NTRansition <val>  
:STATus:QUEStionable:NTRansition?
```

This command determines which bits in the Data Questionable Condition Register will set the corresponding bit in the Data Questionable Event Register when that bit has a negative transition (1 to 0).

The variable <val> is the sum of the decimal values of the bits that you want to enable.

Range 0–32767

Remarks Refer to Chapter 3 of the *E4428C/38C ESG Signal Generators Programming Guide* for more information.

:QUEStionable:POWer:CONDition

Supported All

```
:STATus:QUEStionable:POWer:CONDition?
```

This query returns the decimal sum of the bits in the Data Questionable Power Condition Register. For example, if the RF output signal is unlevelled (bit 1), a value of 2 is returned.

Range 0–32767

Remarks The data in this register is continuously updated and reflects current conditions.

Refer to Chapter 3 of the *E4428C/38C ESG Signal Generators Programming Guide* for more information.

:QUESTionable:POWer:ENABle

Supported All

```
:STATus:QUESTionable:POWer:ENABle <val>  
:STATus:QUESTionable:POWer:ENABle?
```

This command determines which bits in the Data Questionable Power Event Register will set the power summary bit (bit 3) in the Data Questionable Condition Register.

The variable <val> is the sum of the decimal values of the bits that you want to enable.

Range 0–32767

Remarks Refer to Chapter 3 of the *E4428C/38C ESG Signal Generators Programming Guide* for more information.

:QUESTionable:POWer:NTRansition

Supported All

```
:STATus:QUESTionable:POWer:NTRansition <val>  
:STATus:QUESTionable:POWer:NTRansition?
```

This command determines which bits in the Data Questionable Power Condition Register will set the corresponding bit in the Data Questionable Power Event Register when that bit has a negative transition (1 to 0).

The variable <val> is the sum of the decimal values of the bits that you want to enable.

Range 0–32767

Remarks Refer to Chapter 3 of the *E4428C/38C ESG Signal Generators Programming Guide* for more information.

:QUESTionable:POWer:PTRansition

Supported All

```
:STATus:QUESTionable:POWer:PTRansition <val>  
:STATus:QUESTionable:POWer:PTRansition?
```

This command determines which bits in the Data Questionable Power Condition Register will set the corresponding bit in the Data Questionable Power Event Register when that bit has a positive transition (0 to 1).

The variable <val> is the sum of the decimal values of the bits that you want to enable.

Range 0–32767

Status Subsystem (:STATUS)

Remarks Refer to Chapter 3 of the *E4428C/38C ESG Signal Generators Programming Guide* for more information.

:QUESTIONable:POWer[:EVENT]

Supported All

CAUTION This is a destructive read. The data in the register is latched until it is queried. Once queried, the data is cleared.

`:STATUS:QUESTIONable:POWer[:EVENT]?`

This query returns the decimal sum of the bits in the Data Questionable Power Event Register.

Range 0–32767

Remarks The equivalent PTR or NTR filters must be set before the condition register can set the corresponding bit in the event register.

Refer to Chapter 3 of the *E4428C/38C ESG Signal Generators Programming Guide* for more information.

:QUESTIONable:PTRansition

Supported All

`:STATUS:QUESTIONable:PTRansition <val>`

`:STATUS:QUESTIONable:PTRansition?`

This command determines which bits in the Data Questionable Condition Register will set the corresponding bit in the Data Questionable Event Register when that bit has a positive transition (0 to 1).

The variable <val> is the sum of the decimal values of the bits that you want to enable.

Range 0–32767

Remarks Refer to Chapter 3 of the *E4428C/38C ESG Signal Generators Programming Guide* for more information.

:QUEStionable[:EVENT]

Supported All

CAUTION This is a destructive read. The data in the register is latched until it is queried. Once queried, the data is cleared.

:STATus:QUEStionable[:EVENT]?

This query returns the decimal sum of the bits in the Data Questionable Event Register.

Range 0–32767

Remarks The equivalent PTR or NTR filters must be set before the condition register can set the corresponding bit in the event register.

Refer to Chapter 3 of the *E4428C/38C ESG Signal Generators Programming Guide* for more information.

System Subsystem (:SYSTem)

:CAPability

Supported All

:SYSTem:CAPability?

This query returns the signal generator's capabilities and outputs the appropriate specifiers:

```
(RFSOURCE WITH ( (AM|FM|PULM|PM|LFO) & (FSSWEEP|FLIST) & (PSSWEEP|PLIST)
&TRIGGER&REFERENCE) )
```

This is a list of the SCPI-defined basic functionality of the signal generator and the additional capabilities it has in parallel (a&b) and singularly (a|b).

:DATE

Supported All

:SYSTem:DATE <year>, <month>, <day>

:SYSTem:DATE?

This command sets the date as shown in the lower right area of the signal generator display.

<year> This variable requires a four digit integer.

The query returns the date in the following format:

```
<+year>, <+month>, <+day>
```

Range <month>: 1-12 <day>: 1-31

Key Entry Time/Date

:ERRor[:NEXT]

Supported All

:SYSTem:ERRor[:NEXT] ?

This query returns the most recent error message from the signal generator error queue. If there are no error messages, the query returns the following output:

```
+0, "No error"
```

When there is more than one error message, the query will need to be sent for each message.

Key Entry Error Info View Next Error Message

Remarks The ESG deletes the error messages after viewing the last message.

:ERRor:SCPI[:SYNTax]

Supported All

:SYSTem:ERRor:SCPI[:SYNTax] ON|OFF|1|0

:SYSTem:ERRor:SCPI[:SYNTax] ?

This command enables or disables the reporting of SCPI syntax errors to the error queue. The query returns only the numeric value of 1 or 0.

***RST** 0

Remarks The setting ON/1 is persistent through preset and *RST. This setting will not survive a power cycle.

:FILEsystem:SAFEmode

Supported All

:SYSTem:FILEsystem:SAFEmode ON|OFF|1|0

:SYSTem:FILEsystem:SAFEmode?

This command selects the safe mode for file handling. When safe mode is set to OFF, volatile waveform files can be edited and saved while the signal generator plays the file without signal interruption. However, it is possible with complex waveforms, for corruption of memory to occur which will be reported as an error on the front-panel display and require a reboot of the signal generator to resolve.

Example

```
:SYST:FILE:SAVE ON
```

The preceding example enables the safe mode setting and waveform files cannot be edited without

System Commands

System Subsystem (:SYSTem)

signal disruption while the signal generator plays them.

***RST** On

:HELP:MODE

Supported All

:SYSTem:HELP:MODE SINGle|CONTInuous

:SYSTem:HELP:MODE?

This command sets the help function mode of the signal generator.

SINGle Help is provided only for the next key that you press.

CONTInuous Help is provided for each key you press. In addition, the function of the key is executed.

When the help dialog box is displayed, pressing the **Help** hardkey in either mode will turn help off.

Key Entry **Help Mode Single Cont**

Remarks The setting enabled by this command is not affected by signal generator power-on, preset, or *RST.

:IDN

Supported All

:SYSTem:IDN "<string>"

This command modifies the identification string that the *IDN? query returns. Sending an empty string returns the query output of *IDN? to its factory shipped setting. The maximum string length is 72 characters.

Remarks Modification of the *IDN? query output enables the signal generator to identify itself as another signal generator when used as a replacement.

The display diagnostic information, shown by pressing the **Diagnostic Info** softkey, is not affected by this command.

:LANGuage

Supported All

:SYSTem:LANGuage "SCPI"|"COMP"|"NADC"|"PDC"|"PHS"|"8648"

:SYSTem:LANGuage?

This command sets the remote language for the signal generator.

SCPI	This choice provides compatibility for SCPI commands.
COMP	This choice provides compatibility for the 8656B, 8657A/B signal generator which is supported by using the GPIB interface.
NADC	This choice provides compatibility for the 8657D NADC personality which is supported only through a GPIB interface (E4438C only).
PDC	This choice provides compatibility for the 8657D PDC personality which is supported only through a GPIB interface (E4438C only).
PHS	This choice provides compatibility for the 8657J PHS personality which is supported only through a GPIB interface (E4438C only).
8648	This choice provides compatibility for the 8648A/B/C/D signal generator which is supported only through a GPIB interface.
Key Entry	SCPI 8656B,8657A/B 8657D NADC 8657D PDC 8657J PHS 8648A/B/C/D
Remarks	The setting enabled by this command is not affected by signal generator power-on, preset, or *RST. For more information on supported SCPI commands and programming codes, refer to the <i>Programming Compatibility Guide</i> .

:LICense:EXTernal:LIST

Supported All
:SYSTem:LICense:EXTernal:LIST?

This query provides a listing of the current licenses for external software installed on the signal generator.

:OPT

Supported All
:SYSTem:OPT "<string>"

This command modifies the option string that the *OPT? query returns. Sending an empty string sets the query output of *OPT? to the signal generator's factory shipped setting. The maximum string length is 72 characters.

Remarks Modification of the *OPT? query output enables the signal generator, with a set of options, to *identify* itself as another signal generator when used as a replacement

The display diagnostic information, shown by pressing the **Diagnostic Info** softkey, is not affected by this command.

:PON:TYPE

Supported All

:SYSTem: PON: TYPE PRESet | LAST

:SYSTem: PON: TYPE?

This command sets the defined conditions for the signal generator at power on.

PRESet This choice sets the conditions to factory- or user-defined as determined by the choice for the preset type. Refer to “:PRESet:TYPE” on page 160 for selecting the type of preset.

LAST This choice retains the settings at the time the signal generator was last powered down.

NOTE When LAST is selected, no signal generator interaction can occur for at least 3 seconds prior to cycling the power for the current settings to be saved.

Key Entry Power On Last Preset

Remarks The setting enabled by this command is not affected by signal generator power-on, preset, or *RST.

:PRESet

Supported All

SYSTem: PRESet

This command returns the signal generator to a set of defined conditions. It is equivalent to pressing the front panel **Preset** hardkey.

Key Entry Preset

Remarks The defined conditions are either factory- or user-defined. Refer to “:PRESet:TYPE” on page 160 for selecting the type of defined conditions.

:PRESet:ALL

Supported All

:SYSTem: PRESet :ALL

This command sets all states of the signal generator back to their factory default settings, including states that are not normally affected by signal generator power-on, preset, or *RST.

:PRESet:LANGUage

Supported All

```
:SYSTem:PRESet:LANGUage"SCPI"|"COMP"|"NADC"|"PDC"|"PHS"|"8648"  
:SYSTem:PRESet:LANGUage?
```

This command sets the remote language that is available when the signal generator is preset.

SCPI	This choice provides compatibility for SCPI commands.
COMP	This choice provides compatibility for the 8656B, 8657A/B signal generator which is supported by using the GPIB interface.
NADC	This choice provides compatibility for the 8657D NADC personality which is supported only through a GPIB interface (E4438C only).
PDC	This choice provides compatibility for the 8657D PDC personality which is supported only through a GPIB interface (E4438C only).
PHS	This choice provides compatibility for the 8657J PHS personality which is supported only through a GPIB interface (E4438C only).
8648	This choice provides compatibility for the 8648A/B/C/D signal generator which is supported only through a GPIB interface.
*RST	"SCPI"
Key Entry	SCPI 8656B,8657A/B 8657D NADC 8657D PDC 8657J PHS 8648A/B/C/D

:PRESet:PERSistent

Supported All

```
:SYSTem:PRESet:PERSistent
```

This command sets the states that are not affected by signal generator power-on, preset, or *RST to their factory default settings.

Key Entry Restore Sys Defaults

:PRESet:PN9

Supported E4438C Option with Option 001/601 or 002/602

```
:SYSTem:PRESet:PN9 NORMal|QUICK  
:SYSTem:PRESet:PN9?
```

This command sets the preset length of the PN9 sequence for personalities that require software PRBS

System Subsystem (:SYSTem)

generation.

- NORMAL This choice produces a maximal length PN9 sequence.
- QUICK This choice produces a truncated (216 bits) PN9 sequence.
- *RST NORM
- Key Entry** **PN9 Mode Preset**

:PRESet:TYPE

- Supported** All
- :SYSTem:PRESet:TYPE NORMAL|USER
- :SYSTem:PRESet:TYPE?

This command toggles the preset state between factory- and user-defined conditions.

- Key Entry** **Preset Normal User**
- Remarks** Refer to “:PRESet[:USER]:SAVE” for saving the USER choice preset settings.
The setting enabled by this command is not affected by signal generator power-on, preset, or *RST.

:PRESet[:USER]:SAVE

- Supported** All
- :SYSTem:PRESet[:USER]:SAVE

This command saves your user-defined preset conditions to a state file.

- Key Entry** **Save User Preset**
- Remarks** Only one user-defined preset file can be saved. Subsequent saved user-defined preset files will overwrite the previously saved file.

:SECurity:DISPlay

- Supported** All Models
- :SYSTem:SECurity:DISPlay ON|OFF|1|0
- :SYSTem:SECurity:DISPlay?

This command enables or disables the secure display mode.

- On(1) This selection turns the signal generator display back on, showing the current settings. Cycling the signal generator power also restores the display, however the current settings may change depending on the power-on configuration choice. See “:PON:TYPE” on page 158 for information on the power-on choices available.

OFF(0) This selection blanks the signal generator's display, hiding the settings and disabling the front panel keys. While in this mode, the display shows
*** SECURE DISPLAY ACTIVATED ***.

For more information about security functions, refer to the *E4428C/38C ESG Signal Generators User's Guide*.

Example

```
:SYST:SEC:DISP OFF
```

The preceding example enables the secure display mode.

***RST** 1

Range N/A

Key Entry Activate Security Display

:SECurity:ERASeall

Supported All Models

```
:SYSTem:SECurity:ERASall
```

This command removes all user files, flatness correction files, and baseband generator files. In addition, all table editor files are returned to their original factory values.

This command differs from the :DELEte:ALL command, which does not reset table editors to factory values. For more information about security functions, refer to the *E4428C/38C ESG Signal Generators User's Guide*.

Key Entry Erase All

:SECurity:LEVel

Supported All Models

```
:SYSTem:SECurity:LEVel NONE|ERASe|OVERwrite|SANitize  
:SYSTem:SECurity:LEVel?
```

This command selects the security level operation for the signal generator.

NONE This selection causes the signal generator to reset to factory default settings.

ERASe This selection removes all user files, table editor files, flatness correction files, and baseband generator files.

OVERwrite This selection removes all user files, table editor files, flatness correction files,

System Commands

System Subsystem (:SYSTem)

and baseband generator files. The memory is then overwritten with random data.

SRAM All addressable locations will be overwritten with random characters.

Hard Disk All addressable locations will be overwritten with random characters.

Flash Memory The flash blocks will be erased.

SANitize This selection removes all user files, table editor files, flatness correction files, and baseband generator files using the same techniques as the **OVERwrite** selection for SRAM and flash memory. For the hard disk, the signal generator overwrites all addressable locations with a single character, its complement, and then with a random character.

Once you select the security level, you must execute the command from “:SECurity:LEVel:STATe” to arm the security level.

NOTE Once you select a security level and arm it, you cannot change the level.

For other cleaning and security operation descriptions, see “:SECurity:ERASeall” on page 161, “:SECurity:OVERwrite” on page 163, and “:SECurity:SANitize” on page 163. For more information about security functions, refer to the *E4428C/38C ESG Signal Generators User’s Guide*.

Example

```
:SYST:SEC:LEV NONE
```

The preceding example sets the secure mode so it resets the signal generator to factory settings after completing the security operation.

Key Entry **None** **Erase** **Overwrite** **Sanitize**

:SECurity:LEVel:STATe

Supported All Models

CAUTION Ensure that you select the security level prior to executing this command with the **ON (1)** selection. Once you enable the state, you cannot reduce the security level.

```
:SYSTem:SECurity:LEVel:STATe ON|OFF|1|0  
:SYSTem:SECurity:LEVel:STATe?
```

This command arms and executes the current security level parameter.

On (1) This selection arms and prevents any changes to the current security level. Refer

to “:SECurity:LEVel” on page 161 for setting the security level.

OFF (0) This selection performs the actions required for the current security level setting. Cycling the signal generator power also performs the same function.

For more information about security functions, refer to the *E4428C/38C ESG Signal Generators User’s Guide*.

Example

```
:SYST:SEC:LEV:STAT ON
```

The preceding example arms the secure mode selected with the SYSTem:SECurity:LEVel command.

Key Entry **Enter Secure Mode**

:SECurity:OVERwrite

Supported All Models

```
:SYSTem:SECurity:OVERwrite
```

This command removes all user files, table editor files values, flatness correction files, and baseband generator files. The memory is then overwritten with random data as described below. For more information about security functions, refer to the *E4428C/38C ESG Signal Generators User’s Guide*.

SRAM All addressable locations will be overwritten with random characters.

HARD DISK All addressable locations will be overwritten with random characters.

FLASH MEMORY The flash blocks will be erased.

Key Entry **Erase and Overwrite All**

:SECurity:SANitize

Supported All Models

```
:SYSTem:SECurity:SANitize
```

This command removes all user files, table editor files values, flatness correction files, and baseband generator files. The memory is then overwritten with a sequence of data as described below. For more information about security functions, refer to the *E4428C/38C ESG Signal Generators User’s Guide*.

SRAM All addressable locations will be overwritten with random characters.

HARD DISK All addressable locations will be overwritten with a single character and then a random character.

FLASH MEMORY The flash blocks will be erased.

System Subsystem (:SYSTem)

Key Entry **Erase and Sanitize All**

:SSAVer:DELAy

Supported All

:SYSTem:SSAVer:DELAy <val>
:SYSTem:SSAVer:DELAy?

This command sets the amount of time before the display light or display light and text is switched off. This will occur if there is no input via the front panel during the delay period.

The variable <val> is a whole number measured in hours.

Range 1–12

Key Entry **Screen Saver Delay:**

Remarks The setting enabled by this command is not affected by signal generator power-on, preset, or *RST.

Refer to “[:SSAVer:MODE](#)” on page 164 for selecting the screen saver mode.

:SSAVer:MODE

Supported All

:SYSTem:SSAVer:MODE LIGHT|TEXT
:SYSTem:SSAVer:MODE?

This command toggles the screen saver mode between light only or light and text.

LIGHT This choice enables only the light to turn off during the screen saver operation while leaving the text visible on the darkened screen.

TEXT This choice enables both the display light and text to turn off during the screen saver operation.

Key Entry **Screen Saver Mode**

Remarks The setting enabled by this command is not affected by signal generator power-on, preset, or *RST.

:SSAVer:STATe

Supported All

:SYSTem:SSAVer:STATe ON|OFF|1|0
:SYSTem:SSAVer:STATe?

This command enables or disables the display screen saver.

Key Entry **Screen Saver Off On**

Remarks The setting enabled by this command is not affected by signal generator power-on, preset, or *RST.

:TIME

Supported All

:SYSTEM:TIME <hour>, <minute>, <second>

:SYSTEM:TIME?

This command sets the time displayed in the lower right area of the signal generator's display.

Range <hour>: 0–23 <minute>: 0–59 <second>: 0–59

Key Entry **Time/Date**

:VERSion

Supported All

:SYSTEM:VERSion?

This command returns the SCPI version number with which the signal generator complies.

Trigger Subsystem

:ABORt

Supported All

:ABORt

This command causes the List or Step sweep in progress to abort. If INIT:CONT[:ALL] is set to ON, the sweep will immediately re-initiate. The pending operation flag affecting *OPC, *OPC?, and *WAI will undergo a transition once the sweep has been reset.

:INITiate:CONTinuous[:ALL]

Supported All

:INITiate:CONTinuous[:ALL] ON|OFF|1|0

:INITiate:CONTinuous[:ALL]?

This command selects either a continuous or single list or step sweep. Execution of this command does not affect a sweep in progress.

ON (1) This choice selects continuous sweep where, after the completion of the previous sweep, the current sweep will restart automatically or wait until the appropriate trigger source is received.

OFF (0) This choice selects a single sweep. Refer to “:INITiate:IMMediate[:ALL]” on [page 167](#) for single sweep triggering information.

*RST 0

Key Entry Sweep Repeat Single Cont

Remarks Execution of this command will not affect a sweep in progress.

:INITiate[:IMMediate][:ALL]

Supported All

`:INITiate[:IMMediate][:ALL]`

This command either sets or sets and starts a single List or Step sweep, depending on the trigger type. The command performs the following:

- arms a single sweep when BUS, EXTERNAL, or KEY is the trigger source selection
- arms and starts a single sweep when IMMEDIATE is the trigger source selection

This command is ignored if a sweep is in progress. See “:INITiate:CONTinuous[:ALL]” on page 166 for setting continuous or single sweep. See “:TRIGger[:SEquence]:SOURce” on page 168 to select the trigger source.

In some atypical cases, the :INIT command could be ignored if it immediately follows an *OPC? command. If the :INIT command is ignored, then use a 10ms sleep function before sending the command.

Key Entry **Single Sweep**

:TRIGger:OUTPut:POLarity

Supported All

`:TRIGger:OUTPut:POLarity POSitive|NEGative`
`:TRIGger:OUTPut:POLarity?`

Sets the TTL signal level present at the TRIGGER OUT connector to either high (5 vdc) or low (0 vdc). The trigger out is asserted after the frequency and/or power is set while the sweep is waiting for its step trigger. In addition, the swept-sine sends a pulse to the TRIGGER OUT at the beginning of each sweep.

Example

`:TRIG:OUTP:POL NEG`

The preceding example enables the continuous mode as the sweep type.

***RST** POS

Key Entry **Trigger Out Polarity Neg Pos**

:TRIGger[:SEQuence]:SLOPe

Supported All

:TRIGger[:SEQuence]:SLOPe POSitive|NEGative

:TRIGger[:SEQuence]:SLOPe?

This command sets the polarity of the ramp or sawtooth waveform slope present at the TRIG IN connector that will trigger a list or step sweep.

***RST** POS

Key Entry Trigger In Polarity Neg Pos

:TRIGger[:SEQuence]:SOURce

Supported All

:TRIGger[:SEQuence]:SOURce BUS|IMMEDIATE|EXTernal|KEY

:TRIGger[:SEQuence]:SOURce?

This command sets the sweep trigger source for a list or step sweep.

BUS This choice enables GPIB triggering using the *TRG or GET command or LAN and RS-232 triggering using the *TRG command.

IMMEDIATE This choice enables immediate triggering of the sweep event.

EXTernal This choice enables the triggering of a sweep event by an externally applied signal at the TRIG IN connector.

KEY This choice enables triggering through front panel interaction by pressing the **Trigger** hardkey.

***RST** IMM

Remarks The wait for the BUS, EXTernal, or KEY trigger can be bypassed by sending the :TRIGger[:SEQuence][:IMMEDIATE] command.

Example

```
:TRIG:SOUR BUS
```

The preceding example sets the sweep trigger source to BUS.

***RST** IMM

Key Entry Bus Free Run Ext Trigger Key

:TRIGger[:SEQuence][:IMMediate]

Supported All Models

:TRIGger [:SEQuence] [:IMMediate]

This event command causes an armed List or Step sweep to immediately start without the selected trigger occurring.

In some atypical cases, the :TRIG command could be ignored if it immediately follows an *OPC? command. If the :TRIG command is ignored, then use a 10ms sleep function before sending the command.

Unit Subsystem (:UNIT)

:POWer

Supported All

```
:UNIT:POWer DBM|DBUV|DBUVEMF|V|VEMF|DB  
:UNIT:POWer?
```

This command terminates an amplitude value in the selected unit of measure.

If the amplitude reference state is set to on, the query returns units expressed in DB and the DB choice will be displayed. Setting any other unit will cause a setting conflict error stating that the amplitude reference state must be set to off. Refer to, “[:REFERENCE:STATE](#)” on page 67 for more information.

***RST** DBM

Key Entry dBm dBuV dBuVemf mV uV mVemf uVemf DB

Remarks All power values in this chapter are shown with DBM as the unit of measure. If a different unit of measure is selected, replace DBM with the newly selected unit whenever it is indicated for the value.

4 Analog Commands

This chapter provides SCPI descriptions for subsystems dedicated to analog commands common to all ESG signal generator models. This chapter contains the following major sections:

- “Amplitude Modulation Subsystem ([:SOURce])” on page 172
- “Frequency Modulation Subsystem ([:SOURce])” on page 179
- “Low Frequency Output Subsystem ([:SOURce]:LFOutput)” on page 186
- “Phase Modulation Subsystem ([:SOURce])” on page 191
- “Pulse Modulation Subsystem ([:SOURce]:PULM)” on page 199

Amplitude Modulation Subsystem ([:SOURce])

:AM[1]|2...

Supported All Models

[:SOURce] :AM [1] | 2 . . .

This prefix enables the selection of the AM path and is part of most SCPI commands associated with this subsystem. The two paths are equivalent to the **AM Path 1 2** softkey.

AM[1] **AM Path 1 2** with 1 selected

AM2 **AM Path 1 2** with 2 selected

When just AM is shown in a command, this means the command applies globally to both paths.

Each path is set up separately. When a SCPI command uses AM[1], only path one is affected. Consequently, when AM2 is selected, only path two is set up. However, the depth of the signals for the two paths can be coupled.

Depth coupling links the depth value of AM[1] to AM2. Changing the deviation value for one path will change it for the other path.

These two paths can be on at the same time provided the following conditions have been met:

- DUALsine or SWEPTSine is not the selection for the waveform type
- each path uses a different source (Internal 1, Ext1, or Ext2)

:AM:INTernal:FREQUENCY:STEP[:INCRement]

Supported All Models

[:SOURce] :AM :INTernal :FREQUENCY :STEP [: INCRement] <num>

[:SOURce] :AM :INTernal :FREQUENCY :STEP [: INCRement] ?

This command sets the step increment for the amplitude modulation internal frequency.

The variable <num> is expressed in units of Hertz.

Range 0.5–1E6

Key Entry **Incr Set**

Remarks The value set by this command is used with the UP and DOWN choices for the AM frequency setting. Refer to “:AM[1]2:INTernal[1]:FREQuency” on page 174 for more information.

The setting enabled by this command is not affected by signal generator power-on, preset, or *RST.

:AM:WIDeband:STATe

Supported All Models

```
[ :SOURce ] :AM:WIDeband:STATe ON|OFF|1|0
```

```
[ :SOURce ] :AM:WIDeband:STATe?
```

This command enables or disables the wideband amplitude modulation for the selected path.

***RST** 0

Key Entry AM Off On

Remarks The RF carrier is modulated when the modulation state of the signal generator is set to ON, see “:MODulation[:STATe]” on page 129 for more information.

Whenever amplitude modulation is enabled, the AM annunciator is turned on in the display

:AM[1]2:EXTernal[1]2:COUPling

Supported All Models

```
[ :SOURce ] :AM[1]2:EXTernal[1]2:COUPling AC|DC
```

```
[ :SOURce ] :AM[1]2:EXTernal[1]2:COUPling?
```

This command sets the coupling for the amplitude modulation source through the selected external input connector.

AC This choice will only pass ac signal components.

DC This choice will pass both ac and dc signal components.

***RST** DC

Key Entry Ext Coupling DC AC

Remarks The command does not change the currently active source or switch the current modulation on or off. The modulating signal may be the sum of several signals, either internal or external sources.

Amplitude Modulation Subsystem (:SOURce)

:AM[1]2:INTernal[1]:FREQuency

Supported All Models

```
[ :SOURce ] :AM [1] | 2 :INTernal [1] :FREQuency <val><unit> | UP | DOWN
[ :SOURce ] :AM [1] | 2 :INTernal [1] :FREQuency?
```

This command sets the internal amplitude modulation rate for the following applications:

- the first tone of a dual-sine waveform
- the start frequency for a swept-sine waveform
- the frequency rate for all other waveforms

***RST** +4.00000000E+002

Range Dual Sine, Swept-Sine & Sine: 0.1HZ–100kHz
All Other Waveforms: 0.1HZ–20kHz

Key Entry AM Tone 1 Rate AM Start Rate AM Rate

:AM[1]2:INTernal[1]:FREQuency:ALternate

Supported All Models

```
[ :SOURce ] :AM [1] | 2 :INTernal [1] :FREQuency:ALternate <val><unit>
[ :SOURce ] :AM [1] | 2 :INTernal [1] :FREQuency:ALternate?
```

This command sets the frequency for the alternate signal.

***RST** +4.00000000E+002

Range Dual-Sine: 0.1HZ–100kHz Swept-Sine: 0.1HZ–100kHz

Key Entry AM Tone 2 Rate AM Stop Rate

Remarks The alternate signal frequency is the second tone of a dual-sine or the stop frequency of a swept-sine waveform.

Refer to “:AM[1]2:INTernal[1]:FUNctIon:SHAPE” on page 175 for the waveform selection.

:AM[1]|2:INTernal[1]:FREQuency:ALternate:AMPLitude:PERCent**Supported** All Models

```
[ :SOURCE ] :AM [1] | 2 :INTernal [1] :FREQuency:ALternate:AMPLitude:
PERCent <val><unit>
```

```
[ :SOURCE ] :AM [1] | 2 :INTernal [1] :FREQuency:ALternate:AMPLitude:PERCent?
```

This command sets the amplitude of the second tone for a dual-sine waveform as a percentage of the total amplitude. For example, if the second tone makes up 30% of the total amplitude, then the first tone is 70% of the total amplitude.

RST** +5.00000000E+001**Range** 0–100PCT**Key Entry** AM Tone 2 Ampl Percent Of Peak**Remarks** Refer to “:AM[1]|2:INTernal[1]:FUNction:SHAPE” on page 175 for the waveform selection.**:AM[1]|2:INTernal[1]:FUNction:SHAPE*Supported** All Models

```
[ :SOURCE ] :AM [1] | 2 :INTernal [1] :FUNction:SHAPE SINE | TRIangle | SQUare | RAMP |
NOISE | DUALsine | SWEPTsine
```

```
[ :SOURCE ] :AM [1] | 2 :INTernal [1] :FUNction:SHAPE?
```

This command sets the AM waveform type.

RST** SINE**Key Entry** Sine Triangle Square Ramp Noise Dual-Sine Swept-Sine**:AM[1]|2:INTernal[1]:SWEep:TIME*Supported** All Models

```
[ :SOURCE ] :AM [1] | 2 :INTernal [1] :SWEep:TIME <val><unit>
```

```
[ :SOURCE ] :AM [1] | 2 :INTernal [1] :SWEep:TIME?
```

This command sets the sweep rate for the amplitude-modulated, swept-sine waveform.

***RST** +1.00000000E–001**Range** 1mS–65.535S**Key Entry** AM Sweep Time

Amplitude Modulation Subsystem (:SOURce)**:AM[1]|2:INTernal[1]:SWEep:TRIGger****Supported** All Models

```
[ :SOURce ] :AM [1] | 2 :INTernal [1] :SWEep:TRIGger BUS | IMMEDIATE | EXTernal | KEY
[ :SOURce ] :AM [1] | 2 :INTernal [1] :SWEep:TRIGger?
```

This command sets the trigger source for the amplitude modulated swept-sine waveform.

BUS	This choice enables GPIB triggering using the *TRG or GET command or LAN and RS-232 triggering using the *TRG command.
IMMEDIATE	This choice enables immediate triggering of the sweep event.
EXTernal	This choice enables the triggering of a sweep event by an externally applied signal at the TRIG IN connector.
KEY	This choice enables triggering through front panel interaction by pressing the Trigger hardkey.
*RST	IMM
Key Entry	Bus Free Run Ext Trigger Key
Remarks	Refer to “:AM[1] 2:INTernal[1]:FUNCTION:SHAPE” on page 175 for the waveform selection.

:AM[1]|2:SOURce**Supported** All Models

```
[ :SOURce ] :AM [1] | 2 :SOURce INT [1] | EXT [1] | EXT2
[ :SOURce ] :AM [1] | 2 :SOURce?
```

This command sets the source to generate the amplitude modulation.

INT	This choice selects the internal source to provide an ac-coupled signal.
EXT	This choice selects the EXT 1 INPUT or the EXT 2 INPUT connector to provide an externally applied signal that can be ac- or dc-coupled.
*RST	INT
Key Entry	Internal Ext1 Ext2
Remarks	A 1.0 V _p input is required for calibrated AM depth settings. The externally applied, ac-coupled input signal is tested for a voltage level and a display annunciator will report a high or low condition if that voltage is > ±3% of 1 V _p .

:AM[1]|2:STATe**Supported** All Models

[:SOURce] :AM [1] | 2 :STATe ON | OFF | 1 | 0

[:SOURce] :AM [1] | 2 :STATe?

This command enables or disables the amplitude modulation for the selected path.

***RST** 0**Key Entry** AM Off On

Remarks The RF carrier is modulated when you have set the signal generator's modulation state to ON, see [“:MODulation\[:STATe\]” on page 129](#) for more information.

Whenever amplitude modulation is enabled, the AM annunciator is turned on in the display.

The two paths for amplitude modulation can be simultaneously enabled. Refer to [“:AM\[1\]2...” on page 172](#) for more information.

:AM[1]|2[:DEPTh]**Supported** All Models

[:SOURce] :AM [1] | 2 [:DEPTh] [:LINear] <val><unit> | UP | DOWN

[:SOURce] :AM [1] | 2 [:DEPTh] [:LINear] ?

This commands sets the amplitude modulation depth in percent.

***RST** +1.00000000E-001**Range** 0.00-100PCT**Key Entry** AM Depth

Remarks The value of AM depth applies only to whichever AM path configuration (AM[1]|2) you have currently selected. AM Depth is fixed for wideband AM.

When the depth values are coupled, a change made to one path is applied to both. Refer to [“:AM\[1\]2\[:DEPTh\]:TRACK” on page 178](#) for AM depth value coupling.

Refer to [“:AM\[:DEPTh\]:STEP\[:INCRement\]” on page 178](#) for setting the value associated with UP and DOWN choices.

Amplitude Modulation Subsystem (:SOURce)**:AM[1]|2[:DEPTh]:TRACk****Supported** All Models

[:SOURce] :AM [1] | 2 [:DEPTh] [:LINear] :TRACk ON|OFF|1|0

[:SOURce] :AM [1] | 2 [:DEPTh] [LINear] :TRACk?

This command enables or disables the coupling of the AM depth values between the paths (AM[1] and AM2).

ON (1) This choice will link the depth value of AM[1] with AM2; AM2 will assume the AM[1] depth value. For example, if AM[1] depth is set to 15% and AM2 is set to 11%, enabling the depth tracking will cause the AM2 depth value to change to 15%. This applies regardless of the path (AM[1] or AM2) selected in this command

OFF (0) This choice disables the coupling and both paths will have independent depth values.

RST** 0**Key Entry** AM Depth Couple Off On**Remarks** When the depth values are coupled, a change made to one path is applied both.**:AM[:DEPTh]:STEP[:INCRement]*Supported** All Models

[:SOURce] :AM [:DEPTh] :STEP [:INCRement] <val><unit>

[:SOURce] :AM [:DEPTh] :STEP [:INCRement] ?

This command sets the AM depth step increment.

Range 0.1–100PCT**Key Entry** Incr Set

Remarks The value set by this command is used with the UP and DOWN choices for the AM depth setting. Refer to “:AM[1]|2[:DEPTh]” on page 177 for more information.

The setting enabled by this command is not affected by signal generator power-on, preset, or *RST.

Frequency Modulation Subsystem ([:SOURCE])

:FM[1]|2...

Supported All Models

[[:SOURCE]:FM[1]|2...]

This prefix enables the selection of the FM path and is part of most SCPI commands associated with this subsystem. The two paths are equivalent to the **FM Path 1 2** softkey.

FM[1] **FM Path 1 2** with 1 selected

FM2 **FM Path 1 2** with 2 selected

When just FM is shown in a command, this means the command applies globally to both paths.

Each path is set up separately. When a SCPI command uses FM[1], only path one is affected. Consequently, when FM2 is selected, only path two is set up. However, the deviation of the signals for the two paths can be coupled.

Deviation coupling links the deviation value of FM[1] to FM2. Changing the deviation value for one path will change it for the other path.

These two paths can be on at the same time provided the following conditions have been met:

- DUALsine or SWEptsine is not the selection for the waveform type
- each path uses a different source (Internal 1, Ext1, or Ext2)
- FM2 must be set to a deviation less than FM[1]

Frequency Modulation Subsystem (:SOURce)**:FM:INTernal:FREQuency:STEP[:INCRement]****Supported** All Models

[:SOURce]:FM:INTernal:FREQuency:STEP[:INCRement] <num>

[:SOURce]:FM:INTernal:FREQuency:STEP[:INCRement]?

This command sets the step increment for the internal frequency modulation.

The variable <num> sets the entered value in units of Hertz.

RST** +5.00000000E+002**Range** 0.5–1E6**Key Entry** **Incr Set*Remarks** The value set by this command is used with the UP and DOWN choices for the FM frequency setting. Refer to “:FM[1]|2:INTernal[1]:FREQuency” on page 181 for more information.

The setting enabled by this command is not affected by signal generator power-on, preset, or *RST.

:FM[1]|2:EXTernal[1]|2:COUPLing**Supported** All Models

[:SOURce]:FM[1]|2:EXTernal[1]|2:COUPLing AC|DC

[:SOURce]:FM[1]|2:EXTernal[1]|2:COUPLing?

This command sets the coupling for the frequency modulation source through the selected external input connector.

AC This choice will only pass ac signal components.

DC This choice will pass both ac and dc signal components.

RST** DC**Key Entry** **Ext Coupling DC AC*Remarks** The command does not change the currently active source or switch the current modulation on or off. The modulating signal may be the sum of several signals, either internal or external sources.

:FM[1]2:INternal[1]:FREQuency**Supported** All Models

[:SOURce]:FM[1]|2:INternal[1]:FREQuency <val><unit>|UP|DOWN

[:SOURce]:FM[1]|2:INternal[1]:FREQuency?

This command sets the internal frequency modulation rate for the following applications:

- the first tone of a dual-sine waveform
- the start frequency for a swept-sine waveform
- the frequency rate for all other waveforms

***RST** +4.00000000E+002

Range Dual-Sine: 0.1HZ–100KHZ Swept-Sine: 0.1HZ–100KHZ
All Other Waveforms: 0.1HZ–20KHZ

Key Entry FM Tone 1 Rate FM Start Rate FM Rate**:FM[1]2:INternal[1]:FREQuency:ALternate****Supported** All Models

[:SOURce]:FM[1]|2:INternal[1]:FREQuency:ALternate <val><unit>

[:SOURce]:FM[1]|2:INternal[1]:FREQuency:ALternate?

This command sets the frequency for the alternate signal.

***RST** +4.00000000E+002**Range** Dual-Sine: 0.5HZ–1MHZ Swept-Sine: 1HZ–1MHZ**Key Entry** FM Tone 2 Rate FM Stop Rate**Remarks** The alternate signal frequency is the second tone of a dual-sine or the stop frequency of a swept-sine waveform.

Refer to “:FM[1]2:INternal[1]:FUNctIon:SHAPE” on page 182 for the waveform selection.

Frequency Modulation Subsystem (:SOURce)**:FM[1]2:INTernal[1]:FREQuency:ALternate:AMPLitude:PERCent****Supported** All Models[:SOURce]:FM[1]|2:INTernal[1]:FREQuency:ALternate:AMPLitude:
PERCent <val><unit>

[:SOURce]:FM[1]|2:INTernal[1]:FREQuency:ALternate:AMPLitude:PERCent?

This command sets the amplitude of the second tone for a dual-sine waveform as a percentage of the total amplitude. For example, if the second tone makes up 30% of the total amplitude, then the first tone is 70% of the total amplitude.

RST** +1.00000000E+002**Range** 0–100PCT**Key Entry** **FM Tone 2 Ampl Percent Of Peak*Remarks** Refer to “[:FM\[1\]2:INTernal\[1\]:FUNctio:n:SHApe](#)” for the waveform selection.**:FM[1]2:INTernal[1]:FUNctio:n:SHApe****Supported** All Models[:SOURce]:FM[1]|2:INTernal[1]|:FUNctio:n:SHApe SINE|TRIangle|SQUare|RAMP|
NOISe|DUALsine|SWEPTsine

[:SOURce]:FM[1]|2:INTernal[1]|:FUNctio:n:SHApe?

This command sets the FM waveform type.

RST** SINE**Key Entry** **Sine Triangle Square Ramp Noise Dual-Sine Swept-Sine*Remarks** The waveform selection is only valid when INT[1] is the source selection. Refer to “[:FM\[1\]2:SOURce](#)” on page 184 for type source selection.

:FM[1]|2:INTernal[1]:SWEep:TIME

Supported	All Models
	[:SOURce] : FM [1] 2 : INTernal [1] : SWEep : TIME <val><unit>
	[:SOURce] : FM [1] 2 : INTernal [1] : SWEep : TIME?
	This command sets the sweep time for the swept-sine waveform.
*RST	+1.00000000E-001
Range	1.0mS-65.535S
Key Entry	FM Sweep Time
Remarks	Refer to “:FM[1] 2:INTernal[1]:FUNCTION:SHAPE” on page 182 for the waveform selection.

:FM[1]|2:INTernal[1]:SWEep:TRIGger

Supported	All Models
	[:SOURce] : FM [1] 2 : INTernal [1] : SWEep : TRIGger BUS IMMEDIATE EXTERNAL KEY
	[:SOURce] : FM [1] 2 : INTernal [1] : SWEep : TRIGger?
	This command sets the trigger source for the frequency modulated swept-sine waveform.
BUS	This choice enables GPIB triggering using the *TRG or GET command or LAN and RS-232 triggering using the *TRG command.
IMMEDIATE	This choice enables immediate triggering of the sweep event.
EXTERNAL	This choice enables the triggering of a sweep event by an externally applied signal at the TRIG IN connector.
KEY	This choice enables triggering through front panel interaction by pressing the Trigger hardkey.
*RST	IMM
Key Entry	Bus Free Run Ext Trigger Key
Remarks	Refer to “:FM[1] 2:INTernal[1]:FUNCTION:SHAPE” on page 182 for the waveform selection.

Frequency Modulation Subsystem (:SOURce)**:FM[1]|2:SOURce****Supported** All Models

[:SOURce] :FM [1] | 2 :SOURce INT [1] | EXT1 | EXT2

[:SOURce] :FM [1] | 2 :SOURce?

This command sets the source to generate the frequency modulation.

INT This choice selects the internal source to provide an ac-coupled signal.**EXT** This choice selects the EXT 1 INPUT or the EXT 2 INPUT connector to provide an externally applied signal that can be ac- or dc-coupled.***RST** INT**Key Entry** **Internal Ext1 Ext2****Remarks** The externally applied, ac-coupled input signal is tested for a voltage level and a display annunciator will report a high or low condition if that voltage is $> \pm 3\%$ of $1 V_p$.**:FM[1]|2:STATe****Supported** All Models

[:SOURce] :FM [1] | 2 :STATe ON | OFF | 1 | 0

[:SOURce] :FM [1] | 2 :STATe?

This command enables or disables the frequency modulation for the selected path.

RST** 0**Key Entry** **FM Off On*Remarks** The RF carrier is modulated when you set the signal generator's modulation state to ON, see [“:MODulation\[:STATe\]” on page 129](#) for more information.

Whenever frequency modulation is enabled, the FM annunciator is turned on in the display.

The two paths for frequency modulation can be simultaneously enabled. Refer to [“:FM\[1\]|2...” on page 179](#) for more information.

:FM[1]2[:DEVIation]**Supported** All Models

[:SOURce]:FM[1] | 2[:DEVIation] <val><unit>

[:SOURce]:FM[1] | 2[:DEVIation]?

This command sets the frequency modulation deviation.

***RST** +1.0000000E+003

Range	<i>Frequency</i>	<i>Deviation</i>	Deviation Option UNJ
	250kHz–249.999MHz	0–8MHz	0–1MHz
	> 249.999–500MHz	0–4MHz	0–500kHz
	> 500MHz–1GHz	0–8MHz	0–1MHz
	> 1–2GHz	0–16MHz	0–2MHz
	> 2–4GHz	0–32MHz	0–4MHz
	> 4–6GHz	0–8MHz	0–8MHz

Key Entry FM DEV**Remarks** If deviation tracking is ON, a change to the deviation value on one path will apply to both. Refer to “[:FM\[1\]2\[:DEVIation\]:TRACK](#)” on page 185 for more information and setting the deviation tracking.**:FM[1]2[:DEVIation]:TRACK****Supported** All Models

[:SOURce]:FM[1] | 2[:DEVIation]:TRACK ON|OFF|1|0

[:SOURce]:FM[1] | 2[:DEVIation]:TRACK?

This command enables or disables the deviation coupling between the paths (FM[1] and FM2).

ON (1) This choice will link the deviation value of FM[1] with FM2; FM2 will assume the FM[1] deviation value. For example, if FM[1] deviation is set to 500 Hz and FM2 is set to 2 kHz, enabling the deviation tracking will cause the FM2 deviation value to change to 500 Hz. This applies regardless of the path (FM[1] or FM2) selected in this command

OFF (0) This choice disables the coupling and both paths will have independent deviation values.

***RST** 0**Key Entry** FM Dev Couple Off On**Remarks** This command uses exact match tracking, not offset tracking.

Low Frequency Output Subsystem ([:SOURce]:LFOutput)

:AMPLitude

Supported All Models

[:SOURce]:LFOutput:AMPLitude <val><unit>

[:SOURce]:LFOutput:AMPLitude?

This command sets the amplitude for the signal at the LF OUTPUT connector.

***RST** 0.00

Range 0.000VP–5.0VP

Key Entry LF Out Amplitude

:FUNction[1]:FREQuency

Supported All Models

[:SOURce]:LFOutput:FUNction[1]:FREQuency <val><unit>

[:SOURce]:LFOutput:FUNction[1]:FREQuency?

This command sets the internal modulation frequency for the following applications:

- the first tone of a dual-sine waveform
- the start frequency for a swept-sine waveform
- the frequency rate for all other waveforms

***RST** +4.00000000E+002

Range Sine: 0.1HZ–100KHZ Dual-Sine: 0.1HZ–100KHZ

Swept-Sine: 0.1HZ–100KHZ

All Other Waveforms: 0.1HZ–20KHZ

Key Entry LF Out Tone 1 Freq LF Out Start Freq LF Out Freq

Remarks Refer to “:FUNction[1]:SHApe” on page 189 for selecting the waveform type.

Low Frequency Output Subsystem ([:SOURCE]:LFOutput)**:FUNCTION[1]:FREQUENCY:ALTERNATE****Supported** All Models

[:SOURCE]:LFOutput:FUNCTION[1]:FREQUENCY:ALTERNATE <val><unit>

[:SOURCE]:LFOutput:FUNCTION[1]:FREQUENCY:ALTERNATE?

This command sets the frequency for the alternate LF output signal.

RST** +4.00000000E+002**Range** Dual-Sine: 0.1HZ–100KHZ Swept-Sine: 0.1HZ–100KHZ**Key Entry** **LF Out Tone 2 Freq** **LF Out Stop Freq*Remarks** The alternate frequency is the second tone of a dual-sine or the stop frequency of a swept-sine waveform.

Refer to “:FUNCTION[1]:SHAPE” on page 189 for selecting the waveform type.

:FUNCTION[1]:FREQUENCY:ALTERNATE:AMPLITUDE:PERCENT**Supported** All Models

[:SOURCE]:LFOutput:FUNCTION[1]:FREQUENCY:ALTERNATE:AMPLITUDE:PERCENT <val><unit>

[:SOURCE]:LFOutput:FUNCTION[1]:FREQUENCY:ALTERNATE:AMPLITUDE:PERCENT?

This command sets the amplitude of the second tone for a dual-sine waveform as a percentage of the total LF output amplitude. For example, if the second tone makes up 30% of the total amplitude, then the first tone is 70% of the total amplitude.

RST** +5.00000000E+001**Range** 0–100PCT**Key Entry** **LF Out Tone 2 Ampl % of Peak*Remarks** Refer to “:FUNCTION[1]:SHAPE” on page 189 for selecting the waveform type.

Low Frequency Output Subsystem (:SOURce):LFOutput)**:FUNction[1]:PERiod****Supported** All Models

[:SOURce]:LFOutput:FUNction[1]:PERiod <val><unit>

[:SOURce]:LFOutput:FUNction[1]:PERiod?

This command sets the pulse period of the internally generated pulsed low frequency waveform.

RST** +1.60000000E-005**Range** 16uS-30S**Key Entry** **LF Out Period*:FUNction[1]:PWIDth****Supported** All Models

[:SOURce]:LFOutput:FUNction[1]:PWIDth <val><unit>

[:SOURce]:LFOutput:FUNction[1]:PWIDth?

This command sets the pulse width of the internally-generated pulsed low frequency waveform.

The upper limit range value is restricted by the current value of the pulse period. For example, if the pulse period value is set to 16 μ S, the pulse width is limited to a maximum range value of 16 μ S.

RST** +8.00000000E-006**Range** 8uS-30S**Key Entry** **LF Out Width*Remarks** To change the pulse period value, refer to [“:FUNction\[1\]:PERiod” on page 188](#).

Low Frequency Output Subsystem ([:SOURce]:LFOutput)

:FUNction[1]:SHAPE

Supported All Models

```
[:SOURce]:LFOutput:FUNction[1]:SHAPE SINE|DUALsine|SWEPTsine|TRIangle|
SQUare|RAMP|PULSe|NOISE|DC
```

```
[:SOURce]:LFOutput:FUNction[1]:SHAPE?
```

This command sets the waveform type for the generated signal at the LF output.

***RST** SINE

Key Entry Sine Dual-Sine Swept-Sine Triangle Square Ramp Pulse
Noise DC

Remarks Function Generator must be the source selection to support DUALsine or the SWEPTsine waveform. Refer to “[:SOURce]” on page 190.

:FUNction[1]:SWEep:TIME

Supported All Models

```
[:SOURce]:LFOutput:FUNction[1]:SWEep:TIME <val><unit>
```

```
[:SOURce]:LFOutput:FUNction[1]:SWEep:TIME?
```

This command sets the sweep time for an internally generated swept-sine signal at the LF output.

***RST** +1.00000000E-001

Range 1mS-65.535S

Key Entry LF Out Sweep Time

:FUNction[1]:SWEep:TRIGger

Supported All Models

```
[:SOURce]:LFOutput:FUNction[1]:SWEep:TRIGger BUS|IMMediate|EXTernal|KEY
```

```
[:SOURce]:LFOutput:FUNction[1]:SWEep:TRIGger?
```

This command sets the trigger source for the internally generated swept-sine waveform signal at the LF output.

BUS This choice enables GPIB triggering using the *TRG or GET command or LAN and RS-232 triggering using the *TRG command.

IMMediate This choice enables immediate triggering of the sweep event.

EXTernal This choice enables the triggering of a sweep event by an externally applied signal at the TRIG IN connector.

Low Frequency Output Subsystem ([:SOURce]:LFOutput)

KEY	This choice enables triggering through front panel interaction by pressing the Trigger hardkey.
*RST	IMM
Key Entry	Bus Free Run Ext Trigger Key
Remarks	Refer to “[:FUNCTION[1]:SHAPE” on page 189 for selecting the waveform type.

:SOURce

Supported All Models

```
[:SOURce]:LFOutput:SOURce INT[1]|FUNCTION  
[:SOURce]:LFOutput:SOURce?
```

This command sets the low frequency source for the LF output.

INT[1]	This choice enables you to output a signal where the frequency and shape of the signal is set by the internal source as it is being used by a modulation. For example, if the internal source is currently assigned to an AM path configuration and AM is turned on, the signal output at the LF OUTPUT connector will have the frequency and shape of the amplitude modulating signal.
FUNCTION	This choice enables the selection of an internal function generator.
*RST	FUNC
Key Entry	Internal Monitor Function Generator

:STATe

Supported All Models

```
[:SOURce]:LFOutput:STATe ON|OFF|1|0  
[:SOURce]:LFOutput:STATe?
```

This command enables or disables the low frequency output.

*RST	0
Key Entry	LF Out Off On

Phase Modulation Subsystem ([:SOURce])

:PM[1]|2...

Supported All Models

[[:SOURce]:PM[1]|2...]

This prefix enables the selection of the Φ M path and is part of most SCPI commands associated with this subsystem. The two paths are equivalent to the **Φ M Path 1 2** softkey.

PM[1] **Φ M Path 1 2** with 1 selected

PM2 **Φ M Path 1 2** with 2 selected

When just PM is shown in a command, this means the command applies globally to both paths.

Each path is set up separately. When a SCPI command uses PM[1], only path one is affected. Consequently, when PM2 is selected, only path two is set up. However, the deviation of the signals for the two paths can be coupled.

Deviation coupling links the deviation value of PM[1] to PM2. Changing the deviation value for one path will change it for the other path.

These two paths can be on at the same time provided the following conditions have been met:

- DUALsine or SWEPTSine is not the selection for the waveform type
- each path uses a different source (Internal 1, Ext1, or Ext2)
- PM2 must be set to a deviation less than or equal to PM[1]

Phase Modulation Subsystem (:SOURce)

:PM:INTernal:FREQuency:STEP[:INCRement]

Supported All Models

[:SOURce] :PM:INTernal:FREQuency:STEP [: INCRement] <num>

[:SOURce] :PM:INTernal:FREQuency:STEP [: INCRement] ?

This command sets the step increment of the phase modulation internal frequency.

The variable <num> sets the entered value in units of Hertz.

Range 0.5–1E6

Key Entry **Incr Set**

Remarks The value set by this command is used with the UP and DOWN choices for the FM frequency command. Refer to “:PM[1]|2:INTernal[1]:FREQuency” on [page 193](#) for more information.

The setting enabled by this command is not affected by signal generator power-on, preset, or *RST.

:PM[1]|2:BANDwidth|BWIDth

Supported All Models

[:SOURce] :PM [1] | 2 :BANDwidth | BWIDth NORMal | HIGH

[:SOURce] :PM [1] | 2 :BANDwidth | BWIDth ?

This command toggles between normal phase modulation and high bandwidth phase modulation mode.

***RST** NORM

Key Entry **FM ΦM Normal High BW**

:PM[1]|2:EXternal[1]:COUpling

Supported All Models

[:SOURce] :PM [1] | 2 :EXternal [1] :COUpling AC|DC

[:SOURce] :PM [1] | 2 :EXternal [1] :COUpling?

This command sets the coupling for the phase modulation source through the selected external input connector.

AC This choice will only pass ac signal components.

DC This choice will pass both ac and dc signal components.

***RST** DC

Key Entry **Ext Coupling DC AC**

Remarks This command does not change the currently active source or switch the current modulation on or off. The modulating signal may be the sum of several signals, either internal or external sources.

:PM[1]|2:INternal[1]:FREQuency

Supported All Models

[:SOURce] :PM [1] | 2 :INternal [1] :FREQuency <val><unit> |UP|DOWN

[:SOURce] :PM [1] | 2 :INternal [1] :FREQuency?

This command sets the internal modulation frequency rate for the following applications:

- the first tone of a dual-sine waveform
- the start frequency for a swept-sine waveform
- the frequency rate for all other waveforms

***RST** +4.00000000E+002

Range Dual-Sine: 0.1HZ–100KHZ Swept-Sine: 0.1HZ–100KHZ

All Other Waveforms: 0.1HZ–20KHZ

Key Entry **ΦMTone 1 Rate ΦM Start Rate ΦM Rate**

Remarks Refer to “:FUNCTION[1]:SHAPE” on page 189 for selecting the waveform type.

Phase Modulation Subsystem ([:SOURce])**:PM[1]2:INTernal[1]:FREQuency:ALternate****Supported** All Models

[:SOURce]:PM[1]|2:INTernal[1]:FREQuency:ALternate <val><unit>

[:SOURce]:PM[1]|2:INTernal[1]:FREQuency:ALternate?

This command sets the frequency for the alternate signal.

***RST** +4.00000000E+002**Range** Dual-Sine: 0.1HZ–100KHZ Swept-Sine: 0.1HZ–100KHZ**Key Entry** Φ M Stop Rate Φ M Tone 2 Rate**Remarks** The alternate frequency is the second tone of a dual-sine or the stop frequency of a swept-sine waveform.

Refer to “:PM[1]2:INTernal[1]:FUNCTION:SHAPE” on page 195 for the waveform selection.

:PM[1]2:INTernal[1]:FREQuency:ALternate:AMPLitude:PERCent**Supported** All Models

[:SOURce]:PM[1]|2:INTernal[1]:FREQuency:ALternate:AMPLitude:

PERCent <val><unit>

[:SOURce]:PM[1]|2:INTernal[1]:FREQuency:ALternate:AMPLitude:PERCent?

This command sets the amplitude of the second tone for the dual-sine waveform as a percentage of the total amplitude. For example, if the second tone makes up 30% of the total amplitude, then the first tone is 70% of the total amplitude.

***RST** +5.00000000E+001**Range** 0–100PCT**Key Entry** Φ M Tone 2 Ampl Percent of Peak**Remarks** Refer to “:PM[1]2:INTernal[1]:FUNCTION:SHAPE” on page 195 for the waveform selection.

:PM[1]|2:INteRnal[1]:FUNctIon:SHApe**Supported** All Models

[:SOURCE]:PM[1]|2:INteRnal[1]:FUNctIon:SHApe SINE|TRIangle|SQUare|RAMP|NOISe|DUALsine|SWEPTsine

[:SOURCE]:PM[1]|2:INteRnal[1]:FUNctIon:SHApe?

This command sets the phase modulation waveform type.

RST** SINE**Key Entry** Sine Triangle Square Ramp Noise Dual-Sine Swept-Sine**Remarks** The waveform selection is only valid when INT[1] is the source selection. Refer to “:PM[1]|2:SOURCE” on page 196 for type source selection.**:PM[1]|2:INteRnal[1]:SWEep:TIME*Supported** All Models

[:SOURCE]:PM[1]|2:INteRnal[1]:SWEep:TIME <val><unit>

[:SOURCE]:PM[1]|2:INteRnal[1]:SWEep:TIME?

This command sets the sweep time for a phase-modulated, swept-sine waveform.

RST** +1.00000000E-001**Range** 1.0mS-65.535S**Key Entry** Φ M Sweep Time**Remarks** Refer to “:PM[1]|2:INteRnal[1]:FUNctIon:SHApe” for the waveform selection.**:PM[1]|2:INteRnal[1]:SWEep:TRIGger*Supported** All Models

[:SOURCE]:PM[1]|2:INteRnal[1]:SWEep:TRIGger BUS|IMMediate|EXteRnal|KEY

[:SOURCE]:PM[1]|2:INteRnal[1]:SWEep:TRIGger?

This command sets the trigger source for the phase-modulated, swept-sine waveform.

BUS This choice enables GPIB triggering using the *TRG or GET command or LAN and RS-232 triggering using the *TRG command.**IMMediate** This choice enables immediate triggering of the sweep event.**EXteRnal** This choice enables the triggering of a sweep event by an externally applied signal at the TRIG IN connector.

Phase Modulation Subsystem (:SOURce)

KEY	This choice enables triggering through front panel interaction by pressing the Trigger hardkey.
*RST	IMM
Key Entry	Bus Free Run Ext Trigger Key
Remarks	Refer to “:PM[1]2:INTernal[1]:FUNctIon:SHAPE” on page 195 for the waveform selection.

:PM[1]2:SOURce

Supported	All Models
	[:SOURce] :PM [1] 2 :SOURce INT [1] EXT1 EXT2
	[:SOURce] :PM [1] 2 :SOURce?
	This command sets the source to generate the phase modulation.
INT	This choice selects internal source 1 to provide an ac-coupled signal.
EXT	This choice selects the EXT 1 INPUT or the EXT 2 INPUT connector to provide an externally applied signal that can be ac- or dc-coupled.
*RST	INT
Key Entry	Internal 1 Ext1 Ext2
Remarks	The externally applied, ac-coupled input signal is tested for a voltage level and a display annunciator will report a high or low condition if that voltage is > ±3% of 1 V _p .

:PM[1]2:STATe

Supported	All Models
	[:SOURce] :PM [1] 2 :STATe ON OFF 1 0
	[:SOURce] :PM [1] 2 :STATe?
	This command enables or disables the phase modulation for the selected path.
*RST	0
Key Entry	ΦM Off On
Remarks	The RF carrier is modulated when you set the signal generator’s modulation state to ON, see “:MODulation[:STATe]” on page 129 for more information.
	Whenever phase modulation is enabled, the ΦM annunciator is turned on in the display

The two paths for phase modulation can be simultaneously enabled. Refer to “:PM[1]2...” on page 191 for more information.

:PM[1]2[:DEVIation]

Supported All Models

```
[:SOURce]:PM[1]2[:DEVIation] <val><unit>|UP|DOWN
[:SOURce]:PM[1]2[:DEVIation]?
```

This command sets the deviation of the phase modulation.

The variable <unit> will accept RAD (radians), PIRAD (pi-radians), and DEG (degrees); however, the query will only return values in radians.

***RST** +0.00000000E+000

Range	Frequency	Normal Bandwidth	High Bandwidth
	250kHz–249.999MHz	0–10RAD	0–1RAD
	> 249.999–500MHz	0–5RAD	0–0.5RAD
	> 500MHz–1GHz	0–10RAD	0–1RAD
	> 1–2GHz	0–20RAD	0–2RAD
	> 2–4GHz	0–40RAD	0–4RAD
	> 4–6GHz	0–80RAD	0–8RAD

Key Entry Φ M Dev

Remarks If deviation tracking is active, a change to the deviation value on one path will apply to both.

Refer to “:PM[:DEVIation]:STEP[:INCRement]” on page 198 for setting the value associated with the UP and DOWN choices.

:PM[1]2[:DEVIation]:TRACk

Supported All Models

```
[:SOURce]:PM[1]2[:DEVIation]:TRACk ON|OFF|1|0
[:SOURce]:PM[1]2[:DEVIation]:TRACk?
```

This command enables or disables the deviation coupling between the paths (PM[1] and PM2).

ON (1) This choice will link the deviation value of PM[1] with PM2; PM2 will assume the PM[1] deviation value. For example, if PM[1] deviation is set to 500 Hz and

Phase Modulation Subsystem ([:SOURce])

PM2 is set to 2 kHz, enabling the deviation tracking will cause the PM2 deviation value to change to 500 Hz. This applies regardless of the path (PM[1] or PM2) selected in this command.

OFF (0) This choice disables the coupling and both paths will have independent deviation values.

***RST** 0

Key Entry Φ M Dev Couple Off On

Remarks This command uses exact match tracking, not offset tracking.

:PM[:DEVIation]:STEP[:INCRement]

Supported All Models

`[:SOURce]:PM[:DEVIation]:STEP[:INCRement] <val><unit>`

`[:SOURce]:PM[:DEVIation]:STEP[:INCRement]?`

This command sets the phase modulation deviation step increment.

Range 0.001–1E3RAD

Key Entry **Incr Set**

Remarks The value set by this command is used with the UP and DOWN choices for the FM deviation command. Refer to “[\[:PM\[1\]|2\[:DEVIation\]](#)” on page 197 for more information.

The setting enabled by this command is not affected by signal generator power-on, preset, or *RST.

Pulse Modulation Subsystem ([:SOURce]:PULM)

:INTernal[1]:FREQuency

Supported All Models

```
[ :SOURce ] :PULM :INTernal [ 1 ] :FREQuency <val><unit> | UP | DOWN  
[ :SOURce ] :PULM :INTernal [ 1 ] :FREQuency ?
```

This command sets the rate of the internal square wave pulse modulation source.

***RST** +4.00000000E+002

Range 0.1HZ–20.0kHz

Key Entry **Pulse Rate**

Remarks This command is used when SQUare is the current pulse modulation type. Refer to “[:SOURce]” on page 202 for the pulse modulation type selection.

:INTernal[1]:FREQuency:STEP

Supported All Models

```
[ :SOURce ] :PULM :INTernal [ 1 ] :FREQuency :STEP [ : INCRement ] <frequency>MIN | MAX  
[ :SOURce ] :PULM :INTernal [ 1 ] :FREQuency :STEP [ INCRement ] ?
```

This command sets the step value for the internally-generated square wave pulse rate.

This command is used when SQUare is the pulse modulation type. Refer to “[:SOURce]” on page 202 for the pulse modulation type selection. The step value, set with this command, is used with the UP and DOWN choices in the :INTernal[1]:FREQuency command.

The step value set with this command is not affected by a power-on, preset, or *RST command.

Example

```
:PULM :INT :FREQ :STEP MIN
```

The preceding example sets the step value for the square wave pulse rate to 0.1 Hz, the minimum rate.

Range 0.1HZ–20kHz

Pulse Modulation Subsystem ([:SOURCE]:PULM)**:INTERNAL[1]:FUNCTION:SHAPE****Supported** All Models

[:SOURCE]:PULM:INTERNAL[1]:FUNCTION:SHAPE PULSe|SQUare

[:SOURCE]:PULM:INTERNAL[1]:FUNCTION:SHAPE?

This command sets the internal pulse modulation waveform type.

RST** PULS**Key Entry** Internal Square Internal Pulse**:INTERNAL[1]:PERIOD*Supported** All Models

[:SOURCE]:PULM:INTERNAL[1]:PERIOD <val><unit>|UP|DOWN

[:SOURCE]:PULM:INTERNAL[1]:PERIOD?

This command sets the period for the internally generated pulse modulation source.

RST** +8.00000000E-005**Range** 8uS–30S**Key Entry** Pulse Period**Remarks** If the entered value for the pulse period is equal to or less than the value for the pulse width, the pulse width changes to a value that is equal to the pulse period.Refer to “[:INTERNAL\[1\]:PERIOD:STEP\[:INCREMENT\]](#)” on page 200 for setting the value associated with the UP and DOWN choices.**:INTERNAL[1]:PERIOD:STEP[:INCREMENT]*Supported** All Models

[:SOURCE]:PULM:INTERNAL[1]:PERIOD:STEP[:INCREMENT] <val><unit>|UP|DOWN

[:SOURCE]:PULM:INTERNAL[1]:PERIOD:STEP[:INCREMENT]?

This command sets the period time step increment for the internally-generated pulse modulation source.

***RST** +1.00000000E-006**Range** 4uS–30S**Key Entry** Incr Set

Remarks The value set by this command is used with the UP and DOWN choices for the pulse period command. Refer to “:INTErnal[1]:PERiod” on page 200 for more information.

:INTErnal[1]:PWIDth

Supported All Models

```
[ :SOURce ] :PULM :INTErnal [ 1 ] :PWIDth <val><unit> |UP|DOWN
```

```
[ :SOURce ] :PULM :INTErnal [ 1 ] :PWIDth?
```

This command sets the pulse width for the internally generated pulse modulation source.

NOTE A power search is recommended for signals with pulse widths less than one microsecond. Refer to “:ALC:SEARCh” on page 60.

***RST** +4.00000000E-005

Range 4uS–30S

Key Entry **Pulse Width**

Remarks If the entered value for the pulse width is equal to or greater than the value for the pulse period, the pulse width will change to a value that is equal to the pulse period.

Refer to “:INTErnal[1]:PWIDth:STEP” on page 201 for setting the value associated with the UP and DOWN choices.

:INTErnal[1]:PWIDth:STEP

Supported All Models

```
[ :SOURce ] :PULM :INTErnal [ 1 ] :PWIDth:STEP <num>[<time suffix>]
```

```
[ :SOURce ] :PULM :INTErnal [ 1 ] :PWIDth:STEP?
```

This command sets the step increment for the pulse width.

The optional variable [<time suffix>] accepts nS (nano-seconds) to S (seconds).

***RST** +1.00000000E-006

Range 4uS–30S

Remarks The value set by this command is used by the UP and DOWN choices for the pulse width command. Refer to “:INTErnal[1]:PWIDth” on page 201 for more information.

Pulse Modulation Subsystem ([:SOURce]:PULM)

:SOURce

Supported All Models

[[:SOURce]:PULM:SOURce INT|EXT [1] |EXT2

[[:SOURce]:PULM:SOURce?

This command sets the source that will generate the pulse modulation.

***RST** INT

Key Entry Internal Square Internal Pulse Ext1 DC-Coupled Ext2 DC-Coupled

:STATe

Supported All Models

[[:SOURce]:PULM:STATe ON|OFF|1|0

[[:SOURce]:PULM:STATe?

This command enables or disables the operating state of the pulse modulation source.

***RST** 0

Key Entry Pulse Off On

Remarks When pulse modulation is enabled, the PULSE annunciator is shown in the display

5 Component Test Digital Commands

This chapter provides SCPI descriptions for commands dedicated to digital component testing using the E4438C ESG Vector Signal Generator. This chapter contains the following major sections:

- “All Subsystem–Option 001/601 or 002/602 ([:SOURCE])” on page 204
- “AWGN ARB Subsystem–Option 403 ([:SOURCE]:RADio:AWGN:ARB)” on page 205
- “CDMA ARB Subsystem–Option 401 ([:SOURCE]:RADio:CDMA:ARB)” on page 215
- “CDMA2000 ARB Subsystem–Option 401 ([:SOURCE]:RADio:CDMA2000:ARB)” on page 240
- “Dmodulation Subsystem–Option 001/601 or 002/602 ([:SOURCE]:RADio:DMODulation:ARB)” on page 270
- “Dual ARB Subsystem–Option 001/601 or 002/602 ([:SOURCE]:RADio:ARB)” on page 294
- “Multitone Subsystem–Option 001/601 or 002/602 ([:SOURCE]:RADio:MTONE:ARB)” on page 330
- “Wideband CDMA ARB Subsystem–Option 400 ([:SOURCE]:RADio:WCDMa:TGPP:ARB)” on page 344

All Subsystem–Option 001/601 or 002/602 ([:SOURce])

:RADio:ALL:OFF

Supported E4438C with Option 001/601 or 002/602

[:SOURce] :RADio:ALL:OFF

This command disables the digital modulation formats.

Remarks This command does not affect analog modulation.

AWGN ARB Subsystem–Option 403 ([:SOURce]:RADio:AWGN:ARB)

:BWIDth

Supported E4438C with Option 403

[:SOURce]:RADio:AWGN:ARB:BWIDth <val>

[:SOURce]:RADio:AWGN:ARB:BWIDth?

This command adjusts the bandwidth of the AWGN waveform.

The variable <val> is expressed in units of Hertz (Hz–MHz).

***RST** +1.00000000E+006

Range 5E4–1.5E7

Key Entry Bandwidth

:IQ:EXTernal:FILTer

Supported E4438C with Option 403

[:SOURce]:RADio:AWGN:ARB:IQ:EXTernal:FILTer 40e6|THRough

[:SOURce]:RADio:AWGN:ARB:IQ:EXTernal:FILTer?

This command selects the filter or through path for I/Q signals routed to the rear panel I and Q outputs. Selecting a filter setting with this command will automatically set the “:IQ:EXTernal:FILTer:AUTO” on page 206 command to Off mode.

40e6 This choice applies a 40 MHz baseband filter.

THRough This choice bypasses filtering.

***RST** THR

Key Entry 40.000 MHz Through

:IQ:EXTErnal:FILTer:AUTO

Supported E4438C with Option 403

[:SOURce] :RADio:AWGN:ARB:IQ:EXTErnal:FILTer:AUTO ON|OFF|1|0

[:SOURce] :RADio:AWGN:ARB:IQ:EXTErnal:FILTer:AUTO?

This command enables or disables the automatic selection of the filters for I/Q signals routed to the rear panel I/Q outputs.

ON(1) This choice will automatically select a digital modulation filter optimized for the current signal generator settings.

OFF(0) This choice disables the auto feature which lets you select a digital modulation filter or through path. Refer to “[:IQ:EXTErnal:FILTer](#)” on page 205 for selecting a filter or through path.

***RST** ON

Key Entry I/Q Output Filter Manual Auto

:HEADer:CLEAr

Supported E4438C with Option 403

[:SOURce] :RADio:AWGN:ARB:HEADer:CLEAr

This command clears the header information from the file header used by this modulation format.

Key Entry Clear Header

Remarks The **AWGN Off On** softkey must be set to On for this command to function.

:HEADer:SAVE

Supported E4438C with Option 403

[:SOURce] :RADio:AWGN:ARB:HEADer:SAVE

This command saves the header information to the file header used by this modulation format.

Key Entry Save Setup To Header

Remarks The **AWGN Off On** softkey must be set to On for this command to function.

:IQ:MODulation:ATTen

Supported E4438C with Option 403

```
[:SOURce]:RADio:AWGN:ARB:IQ:MODulation:ATTen <val>  
[:SOURce]:RADio:AWGN:ARB:IQ:MODulation:ATTen?
```

This command attenuates the I/Q signals being modulated through the signal generator RF path.

The variable <val> is expressed in units of decibels (dB).

***RST** +2.00000000E+000

Range 0–40

Key Entry **Modulator Atten Manual Auto**

:IQ:MODulation:ATTen:AUTO

Supported E4438C with Option 403

```
[:SOURce]:RADio:AWGN:ARB:IQ:MODulation:ATTen:AUTO ON|OFF|1|0  
[:SOURce]:RADio:AWGN:ARB:IQ:MODulation:ATTen:AUTO?
```

This command enables or disables the I/Q attenuation auto mode.

ON (1) This choice enables the attenuation auto mode which optimizes the modulator attenuation for the current conditions.

OFF (0) This choice holds the attenuator at its current setting or at a selected value. Refer to “[:IQ:MODulation:ATTen](#)” for setting the attenuation value.

***RST** 1

Key Entry **Modulator Atten Manual Auto**

:IQ:MODulation:FILTer

Supported E4438C with Option 403

```
[ :SOURce ] :RADio:AWGN:ARB:IQ:MODulation:FILTer 2.1e6 | 40e6 | THRUgh
[ :SOURce ] :RADio:AWGN:ARB:IQ:MODulation:FILTer?
```

This command enables you to select a filter or through path for I/Q signals modulated onto the RF carrier. Selecting a filter with this command will automatically set “:IQ:MODulation:ATTen:AUTO” on page 207 to Off(0) mode.

2.1E6 This choice applies a 2.1 MHz baseband filter to the I/Q signals.

40E6 This choice applies a 40 MHz baseband filter to the I/Q signals.

THRUgh This choice bypasses filtering.

***RST** THR

Key Entry 2.100 MHz 40.000 MHz Through

:IQ:MODulation:FILTer:AUTO

Supported E4438C with Option 403

```
[ :SOURce ] :RADio:AWGN:ARB:IQ:MODulation:FILTer:AUTO ON | OFF | 1 | 0
[ :SOURce ] :RADio:AWGN:ARB:IQ:MODulation:FILTer:AUTO?
```

This command enables or disables the automatic selection of the filters for I/Q signals modulated onto the RF carrier.

ON(1) This choice will automatically select a digital modulation filter.

OFF(0) This choice disables the auto feature which lets you select a digital modulation filter or through path. Refer to “:IQ:MODulation:FILTer” on page 303 for selecting a filter or through path.

***RST** 1

Key Entry I/Q Mod Filter Manual Auto

:MDEStination:AAMPLitude

Supported E4438C with Option 403

```
[ :SOURce ] :RADio:AWGN:ARB:MDEStination:AAMPLitude NONE | M1 | M2 | M3 | M4  
[ :SOURce ] :RADio:AWGN:ARB:MDEStination:AAMPLitude?
```

This command routes the selected marker to the Alternate Amplitude function. The NONE parameter clears the marker for the Alternate Amplitude function.

***RST** NONE

Key Entry None Marker 1 Marker 2 Marker 3 Marker 4

:MDEStination:ALCHold

Supported E4438C with Option 403

CAUTION Incorrect automatic level control (ALC) sampling can create a sudden unlevelled condition that may create a spike in the RF output potentially damaging a DUT or connected instrument. Ensure that you set markers to let the ALC sample over an amplitude that accounts for the high power levels within the signal.

```
[ :SOURce ] :RADio:AWGN:ARB:MDEStination:ALCHold NONE | M1 | M2 | M3 | M4  
[ :SOURce ] :RADio:AWGN:ARB:MDEStination:ALCHold?
```

This command enables or disables the marker ALC hold function for the selected marker. For setting markers, see “:MARKer:[SET]” on page 306.

Use the ALC hold function when you have a waveform signal that has idle periods, or when the increased dynamic range encountered with RF blanking is not desired. The ALC leveling circuitry responds to the marker signal during the marker pulse (marker signal high), averaging the modulated signal level during this period.

The ALC hold function operates during the low periods of the marker signal. The marker polarity determines when the marker signal is high. For a positive polarity, this is during the marker points. For a negative polarity, this is when there are no marker points. For setting a marker’s polarity, see “:MPOLarity:MARKer1|2|3|4” on page 375.

NOTE Do not use the ALC hold for more than 100 ms, because it can affect the waveform’s output amplitude.

AWGN ARB Subsystem–Option 403 ([:SOURce]:RADio:AWGN:ARB)

The marker signal has a minimum of a two-sample delay in its response relative to the waveform signal response. To compensate for the marker signal delay, offset marker points from the waveform sample point at which you want the ALC sampling to begin.

The ALC hold setting is part of the file header information, so saving the setting to the file header saves the current marker routing for the waveform file.

NOTE A waveform file that has unspecified settings in the file header uses the previous waveform’s routing settings.

For more information on the marker ALC hold function, see the *E4428C/38C ESG Signal Generators User’s Guide*. For setting the marker points, see “:MARKer:[SET]” on page 306.

- NONE This terminates the marker ALC hold function.
- M1–M4 These are the marker choices. The ALC hold feature uses only one marker at a time.
- *RST NONE

Example

```
:RAD:AWGB:ARB:MDES:ALCH M1
```

The preceding example routes marker 1 to the ALC Hold function.

Key Entry	None	Marker 1	Marker 2	Marker 3	Marker 4
Remarks	N/A				

:MDEStination:PULSe

Supported E4438C with Option 403

CAUTION The pulse function incorporates ALC hold. Incorrect automatic level control (ALC) sampling can create a sudden unlevelled condition that may create a spike in the RF output potentially damaging a DUT or connected instrument. Ensure that you set markers to let the ALC sample over an amplitude that accounts for the high power levels within the signal.

```
[[:SOURce]:RADio:ARB:MDEStination:PULSe NONE | M1 | M2 | M3 | M4  
[:SOURce]:RADio:ARB:MDEStination:PULSe?
```

This command enables or disables the marker pulse/RF blanking function for the selected marker.

This function automatically uses the ALC hold function, so there is no need to select both the ALC hold and the pulse/RF blanking for the same marker.

NOTE Do not use ALC hold for more than 100 ms, because it can affect the waveform’s output amplitude.

The signal generator blanks the RF output when the marker signal goes low. The marker polarity determines when the marker signal is low. For a positive polarity, this is during the marker points. For a negative polarity, this is when there are no marker points. For setting a marker’s polarity, see “:MPOLarity:MARKer1|2|3|4” on page 337.

NOTE Set marker points prior to using this function. Enabling this function without setting marker points may create a continuous low or high marker signal, depending on the marker polarity. This causes either no RF output or a continuous RF output. See “:MARKer:[SET]” on page 306 for setting the marker points.

The marker signal has a minimum of a two-sample delay in its response relative to the waveform signal response. To compensate for the marker signal delay, offset marker points from the waveform sample point at which you want the RF blanking to begin. The RF blanking setting is part of the file header information, so saving the setting to the file header saves the current marker routing for the waveform file.

NOTE A waveform file that has unspecified settings in the file header uses the previous waveform’s routing settings. This could create the situation where there is no RF output signal, because the previous waveform used RF blanking.

For more information on the marker RF blanking function, see the *E4428C/38C ESG Signal Generators User’s Guide*.

NONE This terminates the marker RF blanking/pulse function.

M1–M4 These are the marker choices. The RF blanking/pulse feature uses only one marker at a time.

Example

```
:RAD:ARB:MDES:PULS M2
```

The preceding example routes marker 2 to Pulse/RF Blanking.

```
*RST NONE
```

Key Entry None Marker 1 Marker 2 Marker 3 Marker 4

:MPOLarity:MARKer1|2|3|4

Supported E4438C with Option 403

```
[:SOURce]:RADio:AWGN:ARB:MPOLarity:MARKer1|2|3|4 NEGative|POSitive
[:SOURce]:RADio:AWGN:ARB:MPOLarity:MARKer1|2|3|4?
```

This command sets the polarity for the selected marker. For a positive marker polarity, the marker signal is high during the marker points. For a negative marker polarity, the marker signal is high during the period of no marker points.

***RST** POS

Key Entry	Marker 1 Polarity Neg	Marker 2 Polarity Neg	Marker 3 Polarity Neg
	Pos	Pos	Pos
	Marker 4 Polarity Neg Pos		

:LENGth

Supported E4438C with Option 403

```
[:SOURce]:RADio:AWGN:ARB:LENGth 1048576|524288|262144|131072|65536|
32768|16384
[:SOURce]:RADio:AWGN:ARB:LENGth?
```

This command specifies the length (number of points) of the AWGN waveform.

***RST** +524288

Key Entry 1048576 524288 262144 131072 65536 32768 16384

Remarks A longer waveform yields a statistically more correct waveform.

:REfERENCE:EXTErnal:FREQuency

Supported E4438C with Option 403

```
[:SOURce]:RADio:AWGN:ARB:REfERENCE:EXTErnal:FREQuency <val>
[:SOURce]:RADio:AWGN:ARB:REfERENCE:EXTErnal:FREQuency?
```

This command allows you to enter the frequency of the applied external reference.

The variable <val> is expressed in units of hertz (Hz–MHz).

***RST** +1.00000000E+007

Range 2.5E5–1E8

Key Entry Reference Freq

AWGN ARB Subsystem–Option 403 ([:SOURCE]:RADio:AWGN:ARB)

Remarks The value specified by this command is effective only when you are using an external ARB reference applied to the BASEBAND GEN REF IN rear panel connector.

To specify external as the ARB reference source type, refer to “[:REFerence[:SOURCE]]” on page 281.

:REFerence[:SOURCE]

Supported E4438C with Option 403

```
[ :SOURCE ] :RADio:AWGN:ARB:REFerence [ :SOURCE ] INTernal | EXTernal
[ :SOURCE ] :RADio:AWGN:ARB:REFerence [ :SOURCE ] ?
```

This command selects either an internal or external reference for the waveform clock.

***RST** INT

Key Entry ARB Reference Ext Int

Remarks If the EXTernal choice is selected, the external frequency *value must* be entered and the signal must be applied to the BASEBAND GEN REF IN rear panel connector.

Refer to “[:REFerence:EXTernal:FREQuency]” on page 280 to enter the external reference frequency.

:SCLock:RATE

Supported E4438C with Option 403

```
[ :SOURCE ] :RADio:AWGN:ARB:SCLock:RATE <val>
[ :SOURCE ] :RADio:AWGN:ARB:SCLock:RATE?
```

This command sets the sample clock rate for the AWGN modulation format.

The variable <val> is expressed in units of hertz.

***RST** +1.00000000E+008

Range 1–1E8

Key Entry ARB Sample Clock

Remarks The modulation format should be active before executing this command. If this command is executed before the modulation format is active, the entered value will be overridden by a calculated factory default value. Refer to “[:STATE]” on page 214 to activate the modulation format.

AWGN ARB Subsystem–Option 403 (:SOURce):RADio:AWGN:ARB)

:SEED

Supported E4438C with Option 403

[:SOURce] :RADio:AWGN:ARB:SEED FIXed | RANDom

[:SOURce] :RADio:AWGN:ARB:SEED?

This command toggles the AWGN waveform noise seed value type.

FIXed This choice selects a fixed noise seed value.

RANDom This choice selects a randomly generated noise seed value.

***RST** FIX

Key Entry Noise Seed Fixed Random

[:STATe]

Supported E4438C with Option 403

[:SOURce] :RADio:AWGN:ARB [:STATe] ON | OFF | 1 | 0

[:SOURce] :RADio:AWGN:ARB [:STATe] ?

This command enables or disables the AWGN generator function.

***RST** 0

Key Entry Arb AWGN Off On

CDMA ARB Subsystem–Option 401 ([:SOURce]:RADio:CDMA:ARB)

:CLIPping:I

Supported E4438C with Option 401

```
[:SOURce]:RADio:CDMA:ARB:CLIPping:I <val>  
[:SOURce]:RADio:CDMA:ARB:CLIPping:I?
```

This command clips (limits) the modulation level of the waveform's I component to a percentage of full scale.

The variable <val> is expressed in units of percent.

***RST** +1.00000000E+002

Range 10–100

Key Entry Clip |I| To

:CLIPping:POSition

Supported E4438C with Option 401

```
[:SOURce]:RADio:CDMA:ARB:CLIPping:POSition PRE|POST  
[:SOURce]:RADio:CDMA:ARB:CLIPping:POSition?
```

This command specifies whether a waveform is clipped before (PRE) or after (POST) FIR filtering.

***RST** PRE

Key Entry Clip At PRE POST FIR Filter

:CLIPping:Q

Supported E4438C with Option 401

```
[:SOURce]:RADio:CDMA:ARB:CLIPping:Q <val>  
[:SOURce]:RADio:CDMA:ARB:CLIPping:Q?
```

This command clips (limits) the modulation level of the waveform's Q component to a percentage of full scale.

The variable <val> is expressed in units of percent.

***RST** +1.00000000E+002

CDMA ARB Subsystem–Option 401 ([:SOURce]:RADio:CDMA:ARB)

Range 10–100
Key Entry **Clip |Q| To**

:CLIPping:TYPE

Supported E4438C with Option 401

`[:SOURce]:RADio:CDMA:ARB:CLIPping:TYPE IJQ|IORQ`
`[:SOURce]:RADio:CDMA:ARB:CLIPping:TYPE?`

This command selects either IJQ or IORQ as the clipping type.

IJQ The combined I and Q waveform will be clipped (*circular* clipping).

IORQ The I and Q components of the waveform are clipped independently (*rectangular* clipping). I and Q can be clipped to different levels using this mode.

***RST** IJQ

Key Entry **Clipping Type |I+jQ| |I|,|Q|**

:CLIPping[:IJQ]

Supported E4438C with Option 401

`[:SOURce]:RADio:CDMA:ARB:CLIPping[:IJQ] <val>`
`[:SOURce]:RADio:CDMA:ARB:CLIPping[:IJQ]?`

This command clips (limits) the modulation level of the combined I and Q waveform to a percentage of full scale.

The variable <val> is expressed in units of percent.

***RST** +1.00000000E+002

Range 10–100

Key Entry **Clip |I+jQ| To**

:CRATe

Supported E4438C with Option 401

`[:SOURce]:RADio:CDMA:ARB:CRATe <val>`
`[:SOURce]:RADio:CDMA:ARB:CRATe?`

This command sets the chip rate value.

The variable <val> is expressed as chips per second (cps–Mcps).

CDMA ARB Subsystem—Option 401 (:SOURce]:RADio:CDMA:ARB)

***RST** +1.22880000E+006

Range 10–8E6

Key Entry **Chip Rate**

:IQ:EXTernal:FILTer

Supported E4438C with Option 401

[:SOURce] :RADio:CDMA:ARB:IQ:EXTernal:FILTer 40e6 | THRough

[:SOURce] :RADio:CDMA:ARB:IQ:EXTernal:FILTer?

This command selects the filter or through path for I/Q signals routed to the rear panel I and Q outputs. Selecting a filter using this command will automatically set “:IQ:EXTernal:FILTer:AUTO” on [page 217](#) to OFF(0) mode.

40e6 This choice applies a 40 MHz baseband filter.

THRough This choice bypasses filtering.

***RST** THR

Key Entry **40.000 MHz Through**

:IQ:EXTernal:FILTer:AUTO

Supported E4438C with Option 401

[:SOURce] :RADio:CDMA:ARB:IQ:EXTernal:FILTer:AUTO ON | OFF | 1 | 0

[:SOURce] :RADio:CDMA:ARB:IQ:EXTernal:FILTer:AUTO?

This command enables or disables the automatic selection of the filters for I/Q signals routed to the rear panel I/Q outputs.

ON(1) This choice will automatically select a digital modulation filter optimized for the current signal generator settings.

OFF(0) This choice disables the auto feature which lets you select a digital modulation filter or through path. Refer to “:IQ:EXTernal:FILTer” on [page 217](#) for selecting a filter or through path.

***RST** 1

Key Entry **I/Q Output Filter Manual Auto**

:FILTer

Supported E4438C with Option 401

```
[:SOURce]:RADio:CDMA:ARB:FILTer RNYquist|NYquist|GAUSSian|RECTangle|
IS95|IS95_EQ|IS95_MOD|IS95_MOD_EQ|WCDMA|AC4Fm|IS2000SR3DS|UGGaussian|
"<user FIR>"
[:SOURce]:RADio:CDMA:ARB:FILTer?
```

This command selects the pre-modulation filter type.

- IS95 This choice selects a filter that meets the criteria of the IS-95 standard.
- IS95_EQ This choice selects a filter which is a combination of the IS-95 filter (above) and the equalizer filter described in the IS-95 standard. This filter is only used for IS-95 baseband filtering.
- IS95_MOD This choice selects a filter that meets the criteria of the IS-95 error function (for improved adjacent channel performance) with lower passband rejection than the filter specified in the IS-95 standard.
- IS95_MOD_EQ This choice selects a filter which is a combination of the equalizer filter described in the IS-95 standard and a filter that meets the criteria of the IS-95 error function (for improved adjacent channel performance), with lower passband rejection.
- WCDMA This choice selects a 0.22 Nyquist filter optimized for ACP.
- AC4Fm This choice selects a predefined Association of Public Safety Communications Officials (APCO) specified compatible 4-level frequency modulation (C4FM) filter.
- IS2000SR3DS This choice selects an IS-2000 standard, spread rate 3 direct spread filter.
- UGGaussian This choice selects a backwards compatible GSM Gaussian filter (Gaussian filter with a fixed BbT value of 0.300) for the ESG E44xxB Option UN3 or UN4.
- "<user FIR>" This variable is any FIR filter file that you have stored in memory. The variable needs no directory path indicating the location of the file, such as FIR: or /USER/FIR. The command assumes the FIR directory. Refer to [“File Name Variables” on page 13](#) for more information on file names.

***RST** IS95_MOD_EQ

Key Entry	Root Nyquist	Nyquist	Gaussian	Rectangle	IS-95	IS-95 w/EQ
	IS-95 Mod	IS-95 Mod w/EQ	WCDMA	APCO 25 C4FM	IS-2000 SR3 DS	
	UN3/4 GSM Gaussian	User FIR				

:FILTer:ALPHa

Supported E4438C with Option 401

[:SOURce] :RADio:CDMA:ARB:FILTer:ALPHa <val>

[:SOURce] :RADio:CDMA:ARB:FILTer:ALPHa?

This command changes the Nyquist or root Nyquist filter's alpha value.

The filter alpha value can be set to the minimum level (0), the maximum level (1), or in between by using fractional numeric values (0.001–0.999).

***RST** +5.00000000E–001

Range 0.000–1.000

Key Entry Filter Alpha

Remarks To change the current filter type, refer to “:FILTer” on page 218.

:FILTer:BBT

Supported E4438C with Option 401

[:SOURce] :RADio:CDMA:ARB:FILTer:BBT <val>

[:SOURce] :RADio:CDMA:ARB:FILTer:BBT?

This command changes the bandwidth-multiplied-by-bit-time (BbT) filter parameter.

The filter BbT value can be set to the minimum level (0), the maximum level (1), or in between by using fractional numeric values (0.001–0.999).

***RST** +5.00000000E–001

Range 0.000–1.000

Key Entry Filter BbT

Remarks This command is effective only after choosing a Gaussian filter. It does not have an effect on other types of filters.

To change the current filter type, refer to “:FILTer” on page 218.

:FILTER:CHANNEL

Supported E4438C with Option 401

[:SOURCE] :RADIO:CDMA:ARB:FILTER:CHANNEL EVM|ACP
[:SOURCE] :RADIO:CDMA:ARB:FILTER:CHANNEL?

This command optimizes the Nyquist and root Nyquist filters to minimize error vector magnitude (EVM) or to minimize adjacent channel power (ACP).

EVM This choice provides the most ideal passband.

ACP This choice improves stopband rejection.

***RST** EVM

Key Entry **Optimize FIR For EVM ACP**

Remarks To change the current filter type, refer to “[:FILTER](#)” on page 218.

:HEADER:CLEAR

Supported E4438C with Option 401

[:SOURCE] :RADIO:CDMA:ARB:HEADER:CLEAR

This command clears the header information from the file header used by this modulation format.

Key Entry **Clear Header**

Remarks The **CDMA Off On** softkey must be set to On for this command to function.

:HEADER:SAVE

Supported E4438C with Option 401

[:SOURCE] :RADIO:CDMA:ARB:HEADER:SAVE

This command saves the header information to the file header used by this modulation format.

Key Entry **Save Setup To Header**

Remarks The **CDMA Off On** softkey must be set to On for this command to function.

:IQMap

Supported	E4438C with Option 401
	<code>[:SOURCE]:RADio:CDMA:ARB:IQMap NORMAL INVerted</code> <code>[:SOURCE]:RADio:CDMA:ARB:IQMap?</code>
	This command selects whether the Q output will be normal or inverted.
NORMAL	This choice selects normal polarity.
INVerted	This choice inverts the internal Q signal.
*RST	NORM
Key Entry	I/Q Mapping Normal Invert
Remarks	Inverting the Q output inverts the RF spectrum after the modulation.

:IQ:MODulation:ATTen

Supported	E4438C with Option 401
	<code>[:SOURCE]:RADio:CDMA:ARB:IQ:MODulation:ATTen <val></code> <code>[:SOURCE]:RADio:CDMA:ARB:IQ:MODulation:ATTen?</code>
	This command attenuates the I/Q signals being modulated through the signal generator RF path. The variable <val> is expressed in units of decibels (dB).
*RST	+2.00000000E+000
Range	0–40
Key Entry	Modulator Atten Manual Auto

:IQ:MODulation:ATTen:AUTO

Supported	E4438C with Option 401
	<code>[:SOURCE]:RADio:CDMA:ARB:IQ:MODulation:ATTen:AUTO ON OFF 1 0</code> <code>[:SOURCE]:RADio:CDMA:ARB:IQ:MODulation:ATTen:AUTO?</code>
	This command enables or disables the I/Q attenuation auto mode.
ON (1)	This choice enables the attenuation auto mode which optimizes the modulator attenuation for the current conditions.
OFF (0)	This choice holds the attenuator at its current setting or at a selected value. Refer to “:IQ:MODulation:ATTen” on page 221 for setting the attenuation value.

CDMA ARB Subsystem–Option 401 ([:SOURce]:RADio:CDMA:ARB)

***RST** 1
Key Entry Modulator Atten Manual Auto

:IQ:MODulation:FILTer

Supported E4438C with Option 401

[:SOURce]:RADio:CDMA:ARB:IQ:MODulation:FILTer 2.1e6|40e6|THROUGH
 [:SOURce]:RADio:CDMA:ARB:IQ:MODulation:FILTer?

This command enables you to select a filter or through path for I/Q signals modulated onto the RF carrier. Selecting a filter using this command will automatically set “:IQ:MODulation:ATTen:AUTO” on page 221 to OFF(0) mode.

2.1E6 This choice applies a 2.1 MHz baseband filter to the I/Q signals.
 40E6 This choice applies a 40 MHz baseband filter to the I/Q signals.
 THROugh This choice bypasses filtering.

***RST** THR
Key Entry 2.100 MHz 40.000 MHz Through

:IQ:MODulation:FILTer:AUTO

Supported E4438C with Option 401

[:SOURce]:RADio:CDMA:ARB:IQ:MODulation:FILTer:AUTO ON|OFF|1|0
 [:SOURce]:RADio:CDMA:ARB:IQ:MODulation:FILTer:AUTO?

This command enables or disables the automatic selection of the filters for I/Q signals modulated onto the RF carrier.

ON(1) This choice will automatically select a digital modulation filter.
 OFF(0) This choice disables the auto feature which lets you select a digital modulation filter or through path. Refer to “:IQ:MODulation:FILTer” on page 303 for selecting a filter or through path.

***RST** 1
Key Entry I/Q Mod Filter Manual Auto

:MDESTination:AAMPLitude

Supported E4438C with Option 401

[:SOURce]:RADio:CDMA:ARB:MDESTination:AAMPLitude NONE|M1|M2|M3|M4

[:SOURCE]:RADio:CDMA:ARB:MDEStination:AAMPlitude?

This command routes the selected marker to the Alternate Amplitude function. The NONE parameter clears the marker for the Alternate Amplitude function.

*RST NONE

Key Entry None Marker 1 Marker 2 Marker 3 Marker 4

:MDEStination:ALCHold

Supported E4438C with Option 401

CAUTION Incorrect automatic level control (ALC) sampling can create a sudden unlevelled condition that may create a spike in the RF output potentially damaging a DUT or connected instrument. Ensure that you set markers to let the ALC sample over an amplitude that accounts for the high power levels within the signal.

[:SOURCE]:RADio:CDMA:ARB:MDEStination:ALCHold NONE | M1 | M2 | M3 | M4
[:SOURCE]:RADio:CDMA:ARB:MDEStination:ALCHold?

This command enables or disables the marker ALC hold function for the selected marker. For setting markers, see “:MARKer:[SET]” on page 306.

Use the ALC hold function when you have a waveform signal that has idle periods, or when the increased dynamic range encountered with RF blanking is not desired. The ALC leveling circuitry responds to the marker signal during the marker pulse (marker signal high), averaging the modulated signal level during this period.

The ALC hold function operates during the low periods of the marker signal. The marker polarity determines when the marker signal is high. For a positive polarity, this is during the marker points. For a negative polarity, this is when there are no marker points. For setting a marker’s polarity, see “:MPOLarity:MARKer1|2|3|4” on page 226.

NOTE Do not use the ALC hold for more than 100 ms, because it can affect the waveform’s output amplitude.

The marker signal has a minimum of a two-sample delay in its response relative to the waveform signal response. To compensate for the marker signal delay, offset marker points from the waveform sample point at which you want the ALC sampling to begin.

The ALC hold setting is part of the file header information, so saving the setting to the file header saves the current marker routing for the waveform file.

NOTE A waveform file that has unspecified settings in the file header uses the previous waveform’s routing settings.

For more information on the marker ALC hold function, see the *E4428C/38C ESG Signal Generators User’s Guide*. For setting the marker points, see “[:MARKer]:[SET]” on page 306.

NONE This terminates the marker ALC hold function.

M1–M4 These are the marker choices. The ALC hold feature uses only one marker at a time.

***RST** NONE

Example

```
:RAD:AWGB:ARB:MDES:ALCH M1
```

The preceding example routes marker 1 to the ALC Hold function.

Key Entry	None	Marker 1	Marker 2	Marker 3	Marker 4
Remarks	N/A				

:MDEStination:PULSe

Supported E4438C with Option 401

CAUTION The pulse function incorporates ALC hold. Incorrect automatic level control (ALC) sampling can create a sudden unlevelled condition that may create a spike in the RF output potentially damaging a DUT or connected instrument. Ensure that you set markers to let the ALC sample over an amplitude that accounts for the high power levels within the signal.

```
[[:SOURce]:RADio:ARB:MDEStination:PULSe NONE | M1 | M2 | M3 | M4  
[:SOURce]:RADio:ARB:MDEStination:PULSe?
```

This command enables or disables the marker pulse/RF blanking function for the selected marker.

This function automatically uses the ALC hold function, so there is no need to select both the ALC hold and the pulse/RF blanking for the same marker.

NOTE Do not use ALC hold for more than 100 ms, because it can affect the waveform’s

output amplitude.

The signal generator blanks the RF output when the marker signal goes low. The marker polarity determines when the marker signal is low. For a positive polarity, this is during the marker points. For a negative polarity, this is when there are no marker points. For setting a marker’s polarity, see “:MPOLarity:MARKer1|2|3|4” on page 226.

NOTE Set marker points prior to using this function. Enabling this function without setting marker points may create a continuous low or high marker signal, depending on the marker polarity. This causes either no RF output or a continuous RF output. See “:MARKer:[SET]” on page 306 for setting the marker points.

The marker signal has a minimum of a two-sample delay in its response relative to the waveform signal response. To compensate for the marker signal delay, offset marker points from the waveform sample point at which you want the RF blanking to begin. The RF blanking setting is part of the file header information, so saving the setting to the file header saves the current marker routing for the waveform file.

NOTE A waveform file that has unspecified settings in the file header uses the previous waveform’s routing settings. This could create the situation where there is no RF output signal, because the previous waveform used RF blanking.

For more information on the marker RF blanking function, see the *E4428C/38C ESG Signal Generators User’s Guide*.

NONE This terminates the marker RF blanking/pulse function.

M1–M4 These are the marker choices. The RF blanking/pulse feature uses only one marker at a time.

Example

```
:RAD:ARB:MDES:PULS M2
```

The preceding example routes marker 2 to Pulse/RF Blanking.

***RST** NONE

Key Entry None **Marker 1** **Marker 2** **Marker 3** **Marker 4**

:MPOLarity:MARKer1|2|3|4

Supported E4438C with Option 401

```
[:SOURce]:RADio:CDMA:ARB:MPOLarity:MARKer1|2|3|4 NEGative|POSitive
[:SOURce]:RADio:CDMA:ARB:MPOLarity:MARKer1|2|3|4?
```

This command sets the polarity for the selected marker. For a positive marker polarity, the marker signal is high during the marker points. For a negative marker polarity, the marker signal is high during the period of no marker points.

***RST** POS

Key Entry	Marker 1 Polarity Neg	Marker 2 Polarity Neg	Marker 3 Polarity Neg
	Pos	Pos	Pos
	Marker 4 Polarity Neg Pos		

:OSAMple

Supported E4438C with Option 401

```
[:SOURce]:RADio:CDMA:ARB:OSAMple <val>
[:SOURce]:RADio:CDMA:ARB:OSAMple?
```

This command sets the oversampling ratio (number of filter taps per symbol) for CDMA modulation.

***RST** +5

Range 2–8

Key Entry **Oversample Ratio**

Remarks The upper limit of the oversample ratio is adjusted based on the waveform length and chip rate.

Using larger oversample ratios result in more completely filtered images, but this action also uses up more waveform memory.

The maximum oversample ratio is the smaller of 8, 40 Mcps/Chip Rate, or 32/Waveform Length (number of CDMA short codes).

:REFerence:EXTernal:FREQuency

Supported E4438C with Option 401

```
[:SOURce]:RADio:CDMA:ARB:REFerence:EXTernal:FREQuency <val>
[:SOURce]:RADio:CDMA:ARB:REFerence:EXTernal:FREQuency?
```

This command allows you to enter the frequency of the applied external reference.

CDMA ARB Subsystem–Option 401 ([:SOURCE]:RADio:CDMA:ARB)

The variable <val> is expressed in units of Hertz (Hz–MHz).

***RST** +1.00000000E+007

Range 2.5E5–1E8

Key Entry **Reference Freq**

Remarks The value specified by this command is effective only when you are using an external ARB reference applied to the BASEBAND GEN REF IN rear panel connector.

To specify external as the ARB reference source type, refer to “[:REFerence[:SOURCE]]” on page 227.

:REFerence[:SOURCE]

Supported E4438C with Option 401

[:SOURCE]:RADio:CDMA:ARB:REFerence[:SOURCE] INTernal|EXTernal
[:SOURCE]:RADio:CDMA:ARB:REFerence[:SOURCE]?

This command selects either an internal or external reference for the waveform clock.

***RST** INT

Key Entry **ARB Reference Ext Int**

Remarks If the EXTernal choice is selected, the external frequency value *must* be entered and the signal must be applied to the BASEBAND GEN REF IN rear panel connector.

Refer to “[:REFerence:EXTernal:FREQuency]” on page 226 to enter the external reference frequency.

:RETRigger

Supported E4438C with Option 401

[:SOURCE]:RADio:CDMA:ARB:RETRigger ON|OFF|IMMediate
[:SOURCE]:RADio:CDMA:ARB:RETRigger?

This command enables or disables the ARB retriggering mode; the retrigger mode controls how the retriggering function performs while a waveform is playing.

ON(1) This choice specifies that if a trigger occurs while a waveform is playing, the waveform will retrigger at the end of the current waveform sequence and play once more.

OFF(0) This choice specifies that if a trigger occurs while a waveform is playing, the trigger will be ignored.

CDMA ARB Subsystem–Option 401 ([:SOURce]:RADio:CDMA:ARB)

IMMediate This choice specifies that if a trigger occurs while a waveform is playing, the waveform will reset and replay from the start immediately upon receiving a trigger.

***RST** ON

Key Entry **On Off Immediate**

:SCLock:RATE

Supported E4438C with Option 401

[:SOURce]:RADio:CDMA:ARB:SCLock:RATE <val>
[:SOURce]:RADio:CDMA:ARB:SCLock:RATE?

This command sets the sample clock rate for the CDMA modulation format.

The variable <val> is expressed in units of hertz.

***RST** +1.00000000E+008

Range 1–1E8

Key Entry **ARB Sample Clock**

Remarks The modulation format should be active before executing this command. If this command is executed before the modulation format is active, the entered value will be overridden by a calculated factory default value. Refer to “[:STAtE]” on [page 239](#) to activate the modulation format.

:SETup

Supported E4438C with Option 401

[:SOURce]:RADio:CDMA:ARB:SETup FWD9 | FWD32 | FWD64 | PILot | REVerse | MCARrier |
"<file name>"
[:SOURce]:RADio:CDMA:ARB:SETup?

This command selects a pre-defined CDMA channel setup or multicarrier, and turns multicarrier off or on (see the MCARrier choice description).

FWD9 This CDMA setup consists of 9 forward channels (pilot, paging, sync, and 6 traffic channels) at IS-97-defined power levels.

FWD32 This CDMA setup consists of 32 forward channels (pilot, paging, sync, and 29 traffic channels) at IS-97-defined power levels.

FWD64 This CDMA setup consists of 64 forward channels (pilot, 7 paging, sync, and 55 traffic channels) at IS-97-defined power levels.

PILot This choice selects single pilot channel.

CDMA ARB Subsystem—Option 401 ([:SOURCE]:RADio:CDMA:ARB)

REVerse	A single reverse link traffic channel.
MCARrier	This choice selects multicarrier and turns it on. Selecting any other setup such as FWD9 or FWD64 turns multicarrier off. To select the multicarrier setup, see “:SETup:MCARrier” on page 230.
*RST	FWD9
Key Entry	9 Ch Fwd 32 Ch Fwd 64 Ch Fwd Pilot Reverse Multicarrier Off On Multicarrier Off On Custom CDMA State
Remarks	Refer to “File Name Variables” on page 13 for information on the file name syntax.

:SETup:CHANnel

Supported E4438C with Option 401

```
[ :SOURCE ] : RADio : CDMA : ARB : SETup : CHANnel IS97 | EQUAl | SCALe | NONE { , PILOt |
SYNC | PAGing | TRAFFic , <walsh_value> , <power_value> , <pn_offset> , RANDom |
<data_value> }
```

```
[ :SOURCE ] : RADio : CDMA : ARB : SETup : CHANnel ?
```

This command defines the channel parameters of the CDMA signal. This allows for customizing of the channel type, the channel parameters, and the data value.

The variable <power_value> is expressed in units of decibels (dB).

IS97	This choice sets the channel power levels to IS-97-defined power levels.
EQUAL	This choice sets the channel power levels so that all channels are of equal power and the total power equals 0 dBm.
SCALE	This choice scales all of the current channel powers so that the total power equals 0 dB while keeping the previous power ratios between the individual channels.
NONE	This choice bypasses the power level setting.
PILOt	This choice selects a single traffic channel.
SYNC	This choice selects a sync channel.
PAGing	This choice selects a paging channel.
TRAFFic	This choice selects a traffic channel.
RANDom	This choice selects a randomly generated data value.

CDMA ARB Subsystem–Option 401 ([:SOURce]:RADio:CDMA:ARB)

The channel type, walsh code, power, PN offset, and data values are returned when a query is initiated. The output format is as follows:

<channel type>, <walsh_value>, <power>, <pn_offset>, <data_value>

*RST	Channel #	Channel Type	Walsh Code	Power	PN Offset	Data
	1	PIL	+0	-7.00000000E+000	+0	+0
	2	PAG	+1	-7.26000023E+000	+0	RAND
	3	TRAF	+8	-1.02600002E+001	+0	RAND
	4	TRAF	+9	-1.02600002E+001	+0	RAND
	5	TRAF	+10	-1.02600002E+001	+0	RAND
	6	TRAF	+11	-1.02600002E+001	+0	RAND
	7	TRAF	+12	-1.02600002E+001	+0	RAND
	8	TRAF	+13	-1.02600002E+001	+0	RAND
	9	SYNC	+32	-1.02600002E+001	+0	RAND

Range <power_value>: -40 to 0 <walsh_value>: 0-63 <pn_offset>: 0-511

Key Entry **IS-97 Levels** **Equal Powers** **Scale to 0dB** **Sync** **Pilot** **Paging** **Traffic**

:SETup:MCARrier

Supported E4438C with Option 401

[:SOURce]:RADio:CDMA:ARB:SETup:MCARrier CAR3|CAR4|"<file name>"

[:SOURce]:RADio:CDMA:ARB:SETup:MCARrier?

This command selects a pre-defined or user-defined multicarrier CDMA setup.

CAR3 This choice selects three 9 channel forward carriers with a power level of 0.00 dB, the first with a -1.25 MHz frequency offset, the second with no frequency offset, and the third with +1.25 MHz frequency offset.

CAR4 This choice selects four 9 channel forward carriers with a power level of 0.00 dB, the first with a -1.875 MHz frequency offset, the second with a -625 kHz frequency offset, the third with +625 kHz frequency offset, and the fourth with a +1.875 MHz frequency offset.

"<file name>" This choice selects a file consisting of the user-defined number of channel forward carriers, power levels, and frequency offsets.

***RST** CAR3

Key Entry **3 Carriers** **4 Carriers** **Custom CDMA Multicarrier**

Remarks Refer to “File Name Variables” on page 13 for information on the file name syntax.

:SETup:MCARrier:STORE

Supported E4438C with Option 401

```
[:SOURCE]:RADio:CDMA:ARB:SETup:MCARrier:STORE "<file name>"
```

This command stores the current multicarrier setup information.

The stored file contains information including the digital modulation format, number of carriers, frequency spacing, and power settings for the multicarrier setup.

Key Entry Store Custom Multicarrier

Remarks Refer to “File Name Variables” on page 13 for information on the file name syntax.

:SETup:MCARrier:TABLE

Supported E4438C with Option 401

```
[:SOURCE]:RADio:CDMA:ARB:SETup:MCARrier:TABLE {FWD9|FWD32|FWD64|PILot|
CUSTom,"<file name>"|"",<freq_offset>,<power>}
[:SOURCE]:RADio:CDMA:ARB:SETup:MCARrier:TABLE?
```

This command defines the multicarrier CDMA waveform.

The variable <freq_offset> is expressed in units of Hertz (kHz to MHz).

The variable <power> is expressed in units of decibels (dB).

The carrier type, carrier name, frequency offset, and power level are returned when a query is initiated. The output format is as follows:

```
<carrier type>,<carrier_name>,<freq_offset>,<power>
```

FWD9 This CDMA setup consists of 9 forward channels (pilot, paging, sync, and 6 traffic channels) at IS-97-defined power levels.

FWD32 This CDMA setup consists of 32 forward channels (pilot, paging, sync, and 29 traffic channels) at IS-97-defined power levels.

FWD64 This CDMA setup consists of 64 forward channels (pilot, 7 paging, sync, and 55 traffic channels) at IS-97-defined power levels.

PILot This choice selects single pilot channel.

CUSTom,"<file name>" This choice selects a custom user-defined CDMA setup.

" " A null string, entered for any non-custom carrier.

CDMA ARB Subsystem–Option 401 ([:SOURce]:RADio:CDMA:ARB)

*RST	carrier type: FWD9 <freq_offset>: +1.25000000E+006 <power>: +0.00000000E+000
Range	<freq_offset>: -7.5E6 to 7.5E6 <power>: -40 to 0
Key Entry	9 Ch Fwd 32 Ch Fwd 64 Ch Fwd Pilot Custom CDMA State
Remarks	Refer to “ File Name Variables ” on page 13 for information on the file name syntax. To store a multicarrier setup refer to “ :SETup:MCARrier:STORE ” on page 231 The file name specified must be a single carrier CDMA file.

:SETup:STORe

Supported E4438C with Option 401

[:SOURce]:RADio:CDMA:ARB:SETup:STORe "<file name>"

This command stores the current custom CDMA state, using a designated file name, to the signal generator non-volatile memory.

Along with the contents of the CDMA channel table editor (channel types, Walsh code, power levels, PN offset, and data), this command stores the following information to the signal generator non-volatile memory:

- FIR filter
- FIR filter file name
- FIR filter alpha
- FIR filter BbT
- FIR filter channel (EVM or ACP)
- chip rate
- waveform length
- oversample ratio
- ARB reference clock source (internal or external)
- ARB reference clock frequency

Key Entry **Store Custom CDMA State**

Remarks Recall the stored file by executing the following command:

[:SOURce]:RADio:CDMA:ARB:SETup: "<file name>"

Refer to “[File Name Variables](#)” on page 13 for information on the file name syntax.

:TRIGger:TYPE

Supported E4438C with Option 401

```
[:SOURce]:RADio:CDMA:ARB:TRIGger:TYPE CONTInuous | SINGle | GATE  
[:SOURce]:RADio:CDMA:ARB:TRIGger:TYPE?
```

This command sets the trigger mode (type) that controls the waveform's playback.

Triggers control the playback by telling the ESG when to play the modulating signal (waveform). Depending on the trigger settings for the ESG, the waveform playback can occur once, continuously, or the ESG may start and stop playing the waveform repeatedly (GATE mode).

A trigger signal comprises both positive and negative signal transitions (states), which are also called high and low periods. You can configure the ESG to trigger on either state of the trigger signal. It is common to have multiple triggers, also referred to as trigger occurrences or events, occur when the signal generator requires only a single trigger. In this situation, the ESG recognizes the first trigger and ignores the rest.

When you select a trigger mode, you may lose the signal (carrier plus modulating) from the RF output until you trigger the waveform. This is because the ESG sets the I and Q signals to zero volts prior to the first trigger event, which suppresses the carrier. After the first trigger event, the waveform's final I and Q levels determine whether you will see the carrier signal or not (zero = no carrier, other values = carrier visible). At the end of most files, the final I and Q points are set to a value other than zero.

There are four parts to configuring the trigger:

- Choosing the trigger type, which controls the waveform's transmission.
- Setting the waveform's response to triggers:
 - CONTInuous, see [“:TRIGger:TYPE:CONTInuous\[:TYPE\]” on page 234](#)
 - SINGle, see [“:RETRigger” on page 227](#)
 - GATE, selecting the mode also sets the response
- Selecting the trigger source (see [“:TRIGger\[:SOURce\]” on page 235](#)), which determines how the ESG receives its trigger signal, internally or externally. The GATE choice requires an external trigger.
- Setting the trigger polarity when using an external source:
 - CONTInuous and SINGle see [“:TRIGger\[:SOURce\]:EXTErnal:SLOPe” on page 237](#)
 - GATE, see [“:TRIGger:TYPE:GATE:ACTive” on page 235](#)

For more information on triggering, see the *E4428C/38C ESG Signal Generators User's Guide*.

The following list describes the trigger type command choices:

CONTInuous Upon triggering, the waveform repeats continuously.

CDMA ARB Subsystem–Option 401 ([:SOURce]:RADio:CDMA:ARB)

SINGLE	Upon triggering, the waveform segment or sequence plays once.
GATE	An external trigger signal repeatedly starts and stops the waveform’s playback (transmission). The time duration for playback depends on the duty period of the trigger signal and the gate polarity selection (see “:TRIGger:TYPE:GATE:ACTive” on page 235). The waveform plays during the inactive state and stops during the active polarity selection state. The active state can be set high or low. The gate mode works only with an external trigger source.

NOTE The ARB gating behavior described above is opposite to the gating behavior for real-time custom mode.

*RST	CONT
Key Entry	Continuous Single Gated

:TRIGger:TYPE:CONTInuous[:TYPE]

Supported E4438C with Option 401

```
[:SOURce]:RADio:CDMA:ARB:TRIGger:TYPE:CONTInuous[:TYPE] FREE|TRIGger|
RESet
[:SOURce]:RADio:CDMA:ARB:TRIGger:TYPE:CONTInuous[:TYPE] ?
```

This commands selects the waveform’s response to a trigger signal while using the continuous trigger mode.

For more information on triggering and to select the continuous trigger mode, see “:TRIGger:TYPE” on page 233.

The following list describes the waveform’s response to each of the command choices:

FREE	Turning the ARB format on immediately triggers the waveform. The waveform repeats until you turn the format off, select another trigger, or choose another waveform file.
TRIGger	The waveform waits for a trigger before play begins. When the waveform receives the trigger, it plays continuously until you turn the format off, select another trigger, or choose another waveform file.
RESet	The waveform waits for a trigger before play begins. When the waveform receives the trigger, it plays continuously. Subsequent triggers reset the waveform to the beginning. For a waveform sequence, this means to the beginning of the first segment in the sequence.

*RST	FREE		
Key Entry	Free Run	Trigger & Run	Reset & Run

:TRIGger:TYPE:GATE:ACTive

Supported E4438C with Option 401

```
[:SOURce]:RADio:CDMA:ARB:TRIGger:TYPE:GATE:ACTive LOW|HIGH
[:SOURce]:RADio:CDMA:ARB:TRIGger:TYPE:GATE:ACTive?
```

This command selects the active state (gate polarity) of the gate while using the gating trigger mode.

The LOW and HIGH selections correspond to the low and high states of an external trigger signal. For example, when you select HIGH, the active state occurs during the high of the trigger signal. When the active state occurs, the ESG stops the waveform playback at the last played sample point, then restarts the playback at the next sample point when the inactive state occurs. For more information on triggering and to select gating as the trigger mode, see “:TRIGger:TYPE” on page 233.

The following list describes the ESG’s gating behavior for the polarity selections:

LOW	The waveform playback stops when the trigger signal goes low (active state) and restarts when the trigger signal goes high (inactive state).
HIGH	The waveform playback stops when the trigger signal goes high (active state) and restarts when the trigger signal goes low (inactive state).
*RST	HIGH
Key Entry	Gate Active Low High

:TRIGger[:SOURce]

Supported E4438C with Option 401

```
[:SOURce]:RADio:CDMA:ARB:TRIGger[:SOURce] KEY|EXT|BUS
[:SOURce]:RADio:CDMA:ARB:TRIGger[:SOURce]?
```

This command sets the trigger source.

For more information on triggering, see “:TRIGger:TYPE” on page 233. The following list describes the command choices:

KEY	This choice enables manual triggering by pressing the front-panel Trigger hardkey.
EXT	An externally applied signal triggers the waveform. This is the only choice that works with gating. The following conditions affect an external trigger:

CDMA ARB Subsystem—Option 401 ([:SOURCE]:RADio:CDMA:ARB)

- The input connector selected for the trigger signal. You have a choice between the rear-panel PATTERN TRIG IN connector or the PATT TRIG IN 2 pin on the rear-panel AUXILIARY I/O connector. To make the connector selection, see “:TRIGger[:SOURCE]:EXTErnal[:SOURCE]” on page 238.

For more information on the connectors and on connecting the cables, see the *E4428C/38C ESG Signal Generators User’s Guide*.

- The trigger signal polarity:
 - gating mode, see “:TRIGger:TYPE:GATE:ACTive” on page 235
 - continuous and single modes, see “:TRIGger[:SOURCE]:EXTErnal:SLOPe” on page 237
- The time delay between when the ESG receives a trigger and when the waveform responds to the trigger. There are two parts to setting the delay:
 - setting the amount of delay, see “:TRIGger[:SOURCE]:EXTErnal:DELay” on page 236
 - turning the delay on, see “:TRIGger[:SOURCE]:EXTErnal:DELay:STATe” on page 237

BUS This choice enables triggering over the GPIB or LAN using the *TRG or GET commands or the AUXILIARY INTERFACE (RS-232) using the *TRG command.

***RST** KEY

Key Entry Trigger Key Ext Bus

:TRIGger[:SOURCE]:EXTErnal:DELay

Supported E4438C with Option 401

```
[:SOURCE]:RADio:CDMA:ARB:TRIGger[:SOURCE]:EXTErnal:DELay <val>
[:SOURCE]:RADio:CDMA:ARB:TRIGger[:SOURCE]:EXTErnal:DELay?
```

This command sets the amount of time to delay the ESG’s response to an external trigger.

The delay is a path (time) delay between when the ESG receives the trigger and when it responds to the trigger. For example, configuring a trigger delay of two seconds, causes the ESG to wait two seconds after receipt of the trigger before the ESG plays the waveform.

The delay does not occur until you turn it on (see “:TRIGger[:SOURCE]:EXTErnal:DELay:STATe” on page 237). You can set the delay value either before or after turning it on.

For more information on configuring an external trigger source and to select external as the trigger source, see “:TRIGger[:SOURCE]” on page 235.

The unit of measurement for the variable <val> is in seconds (nsec–sec).

CDMA ARB Subsystem—Option 401 ([:SOURce]:RADio:CDMA:ARB)

***RST** +1.00000000E-003

Range 1E-8 to 4E1

Key Entry Ext Delay Time

:TRIGger[:SOURce]:EXTernal:DELAy:STATe

Supported E4438C with Option 401

```
[:SOURce]:RADio:CDMA:ARB:TRIGger[:SOURce]:EXTernal:DELAy:STATe ON|OFF|
1|0
[:SOURce]:RADio:CDMA:ARB:TRIGger[:SOURce]:EXTernal:DELAy:STATe?
```

This command enables or disables the operating state of the external trigger delay function.

For setting the delay time, see “:TRIGger[:SOURce]:EXTernal:DELAy” on page 236, and for more information on configuring an external source, see “:TRIGger[:SOURce]” on page 235.

***RST** 0

Key Entry Ext Delay Off On

:TRIGger[:SOURce]:EXTernal:SLOPe

Supported E4438C with Option 401

```
[:SOURce]:RADio:CDMA:ARB:TRIGger[:SOURce]:EXTernal:SLOPe POSitive|
NEGative
[:SOURce]:RADio:CDMA:ARB:TRIGger[:SOURce]:EXTernal:SLOPe?
```

This command sets the polarity for an external trigger signal while using the continuous, single triggering mode. To set the polarity for gating, see “:TRIGger:TYPE:GATE:ACTive” on page 235.

The POSitive and NEGative selections correspond to the high (positive) and low (negative) states of the external trigger signal. For example, when you select POSitive, the waveform responds (plays) during the high state of the trigger signal. When the ESG receives multiple trigger occurrences when only one is required, the signal generator uses the first trigger and ignores the rest.

For more information on configuring an external trigger source and to select external as the trigger source, see “:TRIGger[:SOURce]” on page 235.

***RST** NEG

Key Entry Ext Polarity Neg Pos

:TRIGger[:SOURce]:EXTeRnal[:SOURce]

Supported E4438C with Option 401

```
[:SOURce]:RADio:CDMA:ARB:TRIGger[:SOURce]:EXTeRnal[:SOURce] EPT1|EPT2|
EPTRIGGER1|EPTRIGGER2
[:SOURce]:RADio:CDMA:ARB:TRIGger[:SOURce]:EXTeRnal[:SOURce]?
```

This command selects which PATTERN TRIG IN connection the ESG uses to accept an externally applied trigger signal when external is the trigger source selection.

For more information on configuring an external trigger source and to select external as the trigger source, see “:TRIGger[:SOURce]” on page 235. For more information on the rear-panel connectors, see the *E4428C/38C ESG Signal Generators User’s Guide*.

The following list describes the command choices:

- EPT1 This choice is synonymous with EPTRIGGER1 and selects the PATTERN TRIG IN rear-panel connector.
 - EPT2 This choice is synonymous with EPTRIGGER2 and selects the PATT TRIG IN 2 pin on the rear-panel AUXILIARY I/O connector.
 - EPTRIGGER1 This choice is synonymous with EPT1 and selects the PATTERN TRIG IN rear-panel connector.
 - EPTRIGGER2 This choice is synonymous with EPT2 and selects the PATT TRIG IN 2 pin on the rear-panel AUXILIARY I/O connector.
 - *RST EPT1
- Key Entry** Patt Trig In 1 Patt Trig In 2

:WLENgth

Supported E4438C with Option 401

```
[:SOURce]:RADio:CDMA:ARB:WLENgth <val>
[:SOURce]:RADio:CDMA:ARB:WLENgth?
```

This command specifies the waveform length (in short codes).

- *RST +1
- Range** 1–6
- Key Entry** Waveform Length
- Remarks** The upper limit is adjusted based on the oversample ratio to fit the signal within the available memory.
The maximum waveform length is 32/oversample ratio.

CDMA ARB Subsystem–Option 401 ([:SOURce]:RADio:CDMA:ARB)**[:STATe]**

Supported E4438C with Option 401

[:SOURce]:RADio:CDMA:ARB[:STATe] ON|OFF|1|0

[:SOURce]:RADio:CDMA:ARB[:STATe]?

This command enables or disables the CDMA modulation format.

Executing the command [:SOURce]:RADio:CDMA:ARB[:STATe] ON sets up the internal hardware to generate the currently selected CDMA signal selection. This also activates the I/Q state and sets the I/Q source to internal.

ON (1) This choice sets up the internal hardware to generate the currently selected CDMA signal selection. This also activates the I/Q state and sets the I/Q source to internal.

OFF (0) This choice disables the CDMA modulation format.

***RST** 0

Key Entry **CDMA Off On**

Remarks The enabled modulation is not present on RF carrier until you have activated the modulation by executing the command :OUTPut:MODulation[:STATe] ON.

Overriding the I/Q state and I/Q source functions can be achieved by using the I/Q menu.

CDMA2000 ARB Subsystem–Option 401 ([:SOURce]:RADio:CDMA2000:ARB)

:CLIPping:I

Supported E4438C with Option 401

```
[:SOURce]:RADio:CDMA2000:ARB:CLIPping:I <val>  
[:SOURce]:RADio:CDMA2000:ARB:CLIPping:I?
```

This command clips (limits) the modulation level of the waveform's I component to a percentage of full scale.

The variable <val> is expressed in units of percent.

***RST** +1.00000000E+002

Range 10–100

Key Entry Clip |I| To

:CLIPping:POSition

Supported E4438C with Option 401

```
[:SOURce]:RADio:CDMA2000:ARB:CLIPping:POSition PRE|POST  
[:SOURce]:RADio:CDMA2000:ARB:CLIPping:POSition?
```

This command specifies whether a waveform is clipped before (PRE) or after (POST) FIR filtering.

***RST** PRE

Key Entry Clip At PRE POST FIR Filter

:CLIPping:Q

Supported E4438C with Option 401

```
[:SOURce]:RADio:CDMA2000:ARB:CLIPping:Q <val>  
[:SOURce]:RADio:CDMA2000:ARB:CLIPping:Q?
```

This command clips (limits) the modulation level of the waveform's Q component to a percentage of full scale.

The variable <val> is expressed in units of percent.

***RST** +1.00000000E+002

Range 10–100

Key Entry **Clip |Q| To**

:CLIPping:TYPE

Supported E4438C with Option 401

```
[:SOURce]:RADio:CDMA2000:ARB:CLIPping:TYPE IJQ|IORQ
[:SOURce]:RADio:CDMA2000:ARB:CLIPping:TYPE?
```

This command selects either IJQ or IORQ as the clipping type.

IJQ This choice clips (circular clipping) the combined I and Q waveform.

IORQ This choice independently clips (rectangular clipping) I and Q components of the waveform. I and Q can be clipped to different levels using this mode.

***RST** IORQ

Key Entry **Clipping Type |I+jQ| |I|,|Q|**

:CLIPping[:IJQ]

Supported E4438C with Option 401

```
[:SOURce]:RADio:CDMA2000:ARB:CLIPping[:IJQ] <val>
[:SOURce]:RADio:CDMA2000:ARB:CLIPping[:IJQ]?
```

This command clips (limits) the modulation level of the combined I and Q waveform to a percentage of full scale.

The variable <val> is expressed in units of percent.

***RST** +1.00000000E+002

Range 10–100

Key Entry **Clip |I+jQ| To**

:IQ:EXTernal:FILTer

Supported E4438C with Option 401

```
[:SOURce]:RADio:CDMA2000:ARB:IQ:EXTernal:FILTer 40e6|THROUGH
[:SOURce]:RADio:CDMA2000:ARB:IQ:EXTernal:FILTer?
```

This command selects the filter or through path for I/Q signals routed to the rear panel I and Q outputs. Selecting a filter using this command will automatically set “[:IQ:EXTernal:FILTer:AUTO](#)” on [page 242](#) to OFF(0) mode.

40e6 This choice applies a 40 MHz baseband filter.

CDMA2000 ARB Subsystem–Option 401 ([:SOURce]:RADio:CDMA2000:ARB)

THRough This choice bypasses filtering.

*RST THR

Key Entry 40.000 MHz Through

:IQ:EXTeRnal:FiLTeR:AUTO

Supported E4438C with Option 401

[:SOURce]:RADio:ARB:IQ:EXTeRnal:FiLTeR:AUTO ON|OFF|1|0

[:SOURce]:RADio:ARB:IQ:EXTeRnal:FiLTeR:AUTO?

This command enables or disables the automatic selection of the filters for I/Q signals routed to the rear panel I/Q outputs.

ON(1) This choice will automatically select a digital modulation filter optimized for the current signal generator settings.

OFF(0) This choice disables the auto feature which lets you select a digital modulation filter or through path. Refer to “:IQ:EXTeRnal:FiLTeR” on page 241 for selecting a filter or through path.

*RST 1

Key Entry I/Q Output Filter Manual Auto

:FiLTeR

Supported E4438C with Option 401

[:SOURce]:RADio:CDMA2000:ARB:FiLTeR RNYQuist|NYQuist|GAUSSian|RECTangle|IS95|IS95_EQ|IS95_MOD|IS95_MOD_EQ|AC4Fm|WCDMA|IS2000SR3DS|UGGaussian|<user FIR>

[:SOURce]:RADio:CDMA2000:ARB:FiLTeR?

This command selects the pre-modulation filter type.

IS95 This choice selects a filter that meets the criteria of the IS-95 standard.

IS95_EQ This choice selects a filter which is a combination of the IS-95 filter (above) and the equalizer filter described in the IS-95 standard. This filter is only used for IS-95 baseband filtering.

IS95_MOD This choice selects a filter that meets the criteria of the IS-95 error function (for improved adjacent channel performance) with lower passband rejection than the filter specified in the IS-95 standard.

IS95_MOD_EQ This choice selects a filter which is a combination of the equalizer filter described in the IS-95 standard and a filter that meets the criteria of the IS-95 error function

CDMA2000 ARB Subsystem–Option 401 (:SOURce]:RADio:CDMA2000:ARB)

	(for improved adjacent channel performance), with lower passband rejection.																		
WCDMa	This choice selects a 0.22 Nyquist filter optimized for ACP.																		
AC4Fm	This choice selects the Association of Public Safety Communications Officials (APCO) specified compatible 4-level frequency modulation (C4FM) filter.																		
IS2000SR3DS	This choice selects an IS-2000 standard, spread rate 3 direct spread filter.																		
UGaussian	This choice selects a backwards compatible GSM Gaussian filter (Gaussian filter with a fixed BbT value of 0.300) for the ESG E44xxB Option UN3 or UN4.																		
"<user FIR>"	This variable is any FIR filter file that you have stored in memory. The variable needs no directory path indicating the location of the file, such as FIR: or /USER/FIR. The command assumes the FIR directory. Refer to “File Name Variables” on page 13 for more information on file names.																		
*RST	IS95_MOD_EQ																		
Key Entry	<table> <tr> <td>Root Nyquist</td> <td>Nyquist</td> <td>Gaussian</td> <td>Rectangle</td> <td>IS-95</td> <td>IS-95 w/EQ</td> </tr> <tr> <td>IS-95 Mod</td> <td>IS-95 Mod w/EQ</td> <td>APCO 25 C4FM</td> <td>WCDM</td> <td>A</td> <td></td> </tr> <tr> <td>UN3/4 GSM Gaussian</td> <td>IS-2000 SR3 DS</td> <td>User FIR</td> <td></td> <td></td> <td></td> </tr> </table>	Root Nyquist	Nyquist	Gaussian	Rectangle	IS-95	IS-95 w/EQ	IS-95 Mod	IS-95 Mod w/EQ	APCO 25 C4FM	WCDM	A		UN3/4 GSM Gaussian	IS-2000 SR3 DS	User FIR			
Root Nyquist	Nyquist	Gaussian	Rectangle	IS-95	IS-95 w/EQ														
IS-95 Mod	IS-95 Mod w/EQ	APCO 25 C4FM	WCDM	A															
UN3/4 GSM Gaussian	IS-2000 SR3 DS	User FIR																	

:FILTer:ALPHa

Supported E4438C with Option 401

[:SOURce] :RADio:CDMA2000:ARB:FILTer:ALPHa <val>

[:SOURce] :RADio:CDMA2000:ARB:FILTer:ALPHa?

This command changes the Nyquist or root Nyquist filter alpha value.

The filter alpha value can be set to the minimum level (0), the maximum level (1), or in between by using fractional numeric values (0.001–0.999).

***RST** +5.00000000E–001

Range 0.000–1.000

Key Entry **Filter Alpha**

Remarks To change the current filter type, refer to [“:FILTer” on page 242](#).

:FILTer:BBT

Supported E4438C with Option 401

```
[:SOURce]:RADio:CDMA2000:ARB:FILTer:BBT <val>
```

```
[:SOURce]:RADio:CDMA2000:ARB:FILTer:BBT?
```

This command changes the bandwidth-multiplied-by-bit-time (BbT) filter parameter.

The filter BbT value can be set to the minimum level (0), the maximum level (1), or in between by using fractional numeric values (0.001–0.999).

***RST** +5.00000000E–001

Range 0.000–1.000

Key Entry **Filter BbT**

Remarks This command is effective only after choosing a Gaussian filter. It does not have an effect on other types of filters.

To change the current filter type, refer to “:FILTer” on page 242.

:FILTer:CHANnel

Supported E4438C with Option 401

```
[:SOURce]:RADio:CDMA2000:ARB:FILTer:CHANnel EVM|ACP
```

```
[:SOURce]:RADio:CDMA2000:ARB:FILTer:CHANnel?
```

This command optimizes the Nyquist and root Nyquist filters to minimize error vector magnitude (EVM) or to minimize adjacent channel power (ACP).

EVM This choice provides the most ideal passband.

ACP This choice improves stopband rejection.

***RST** EVM

Key Entry **Optimize FIR For EVM ACP**

Remarks To change the current filter type, refer to “:FILTer” on page 242.

:HEADer:CLEar

Supported E4438C with Option 401

[:SOURCE] :RADio:CDMA2000:ARB:HEADer:CLEar

This command clears the header information from the file header used by this modulation format.

Key Entry **Clear Header**

Remarks The **CDMA2000 Off On** softkey must be set to On for this command to function.

:HEADer:SAVE

Supported E4438C with Option 401

[:SOURCE] :RADio:CDMA2000:ARB:HEADer:SAVE

This command saves the header information to the file header used by this modulation format.

Key Entry **Save Setup To Header**

Remarks The **CDMA2000 Off On** softkey must be set to On for this command to function.

:IQ:MODulation:ATTen

Supported E4438C with Option 401

[:SOURCE] :RADio:CDMA2000:ARB:IQ:MODulation:ATTen <val>
[:SOURCE] :RADio:CDMA2000:ARB:IQ:MODulation:ATTen?

This command attenuates the I/Q signals being modulated through the signal generator RF path.

The variable <val> is expressed in units of decibels (dB).

***RST** +2.00000000E+000

Range 0–40

Key Entry **Modulator Atten Manual Auto**

:IQ:MODulation:ATTen:AUTO

Supported E4438C with Option 401

```
[:SOURce]:RADio:CDMA2000:ARB:IQ:MODulation:ATTen:AUTO ON|OFF|1|0
[:SOURce]:RADio:CDMA2000:ARB:IQ:MODulation:ATTen:AUTO?
```

This command enables or disables the I/Q attenuation auto mode.

ON (1) This choice enables the attenuation auto mode which optimizes the modulator attenuation for the current conditions.

OFF (0) This choice holds the attenuator at its current setting or at a selected value. Refer to “:IQ:MODulation:ATTen” on page 245 for setting the attenuation value.

***RST** 1

Key Entry Modulator Atten Manual Auto

:IQ:MODulation:FILTer

Supported E4438C with Option 401

```
[:SOURce]:RADio:CDMA2000:ARB:IQ:MODulation:FILTer 2.1e6|40e6|THROUGH
[:SOURce]:RADio:CDMA2000:ARB:IQ:MODulation:FILTer?
```

This command enables you to select a filter or through path for I/Q signals modulated onto the RF carrier. Selecting a filter using this command will automatically set “:IQ:MODulation:FILTer:AUTO” on page 246 to OFF(0) mode.

2.1E6 This choice applies a 2.1 MHz baseband filter to the I/Q signals.

40E6 This choice applies a 40 MHz baseband filter to the I/Q signals.

THROUGH This choice bypasses filtering.

***RST** THR

Key Entry 2.100 MHz 40.000 MHz Through

:IQ:MODulation:FILTer:AUTO

Supported E4438C with Option 401

```
[:SOURce]:RADio:CDMA2000:ARB:IQ:MODulation:FILTer:AUTO ON|OFF|1|0
[:SOURce]:RADio:CDMA2000:ARB:IQ:MODulation:FILTer:AUTO?
```

This command enables or disables the automatic selection of the filters for I/Q signals modulated onto the RF carrier.

ON(1) This choice will automatically select a digital modulation filter.

CDMA2000 ARB Subsystem–Option 401 (:SOURce]:RADio:CDMA2000:ARB)

OFF(0) This choice disables the auto feature which lets you select a digital modulation filter or through path. Refer to “:IQ:MODulation:FILTer” on page 246 for selecting a filter or through path.

***RST** 1

Key Entry **I/Q Mod Filter Manual Auto**

:IQMap

Supported E4438C with Option 401

```
[ :SOURce ] :RADio:CDMA2000:ARB:IQMap NORMal | INVerted
[ :SOURce ] :RADio:CDMA2000:ARB:IQMap?
```

This command selects whether the Q output will be normal or inverted.

NORMal This choice selects normal polarity.

INVerted This choice inverts the internal Q signal.

***RST** NORM

Key Entry **I/Q Mapping Normal Invert**

Remarks Inverting the Q output inverts the RF spectrum after the modulation.

:LINK

Supported E4438C with Option 401

```
[ :SOURce ] :RADio:CDMA2000:ARB:LINK FORWard | REVerse
[ :SOURce ] :RADio:CDMA2000:ARB:LINK?
```

This command selects the CDMA2000 forward or reverse link channel setup.

FORW This choice selects a basestation to mobile configuration.

REV This choice selects a mobile to basestation configuration.

***RST** FORW

Key Entry **Link Forward Reverse**

:LINK:FORWARD:SETup

Supported E4438C with Option 401

```
[ :SOURce ] :RADio:CDMA2000:ARB:LINK:FORWARD:SETup S1Pilot | S3DPilot |
S3MPilot | S19Chan | S3D9chan | S3M9chan | MCArrier | "<file name>"
[ :SOURce ] :RADio:CDMA2000:ARB:LINK:FORWARD:SETup?
```

CDMA2000 ARB Subsystem–Option 401 ([:SOURce]:RADio:CDMA2000:ARB)

This command selects a previously defined channel configuration for the CDMA2000 forward link or multicarrier, and turns multicarrier off or on (see the MCARrier choice description).

S1Pilot	This choice selects a spread rate 1, pilot-channel setup.
S3DPilot	This choice selects a spread rate 3, direct spread, pilot-channel setup.
S3MPilot	This choice selects a spread rate 3, multicarrier spread, pilot-channel setup.
S19Chan	This choice selects a spread rate 1, 9-channel setup.
S3D9Chan	This choice selects a spread rate 3, direct spread, 9-channel setup.
S3M9Chan	This choice selects a spread rate 3, multicarrier spread, 9-channel setup.
MCARrier	This choice selects multicarrier and turns it on. Selecting any other setup such as S1Pilot or S3D9Chan turns multicarrier off. To select the multicarrier setup, see “:LINK:FORWARD:SETup:MCARrier” .
*RST	S19C
Key Entry	Pilot 9 Channel Spread Rate 1 Spread Rate 3 Multicarrier Off On Spreading Type Direct Mcarrier Custom CDMA2000 Carrier
Remarks	Refer to “File Name Variables” on page 13 for information on the file name syntax.

:LINK:FORWARD:SETup:MCARrier

Supported E4438C with Option 401

```
[:SOURce]:RADio:CDMA2000:ARB:LINK:FORWARD:SETup:MCARrier CAR2|CAR3|CAR4|
"<file name>"
```

```
[:SOURce]:RADio:CDMA2000:ARB:LINK:FORWARD:SETup:MCARrier?
```

This command defines the type of multicarrier CDMA2000 setup.

CAR2	This choice specifies the following standard 2-carrier setup: Carrier 1: spread rate 3, direct spread, 9 channel; –2.5 MHz frequency offset; 0 dB power Carrier 2: spread rate 3, direct spread, 9 channel; 2.5 MHz frequency offset; 0 dB power
CAR3	This choice specifies the following standard 3-carrier setup: Carrier 1: spread rate 1, 9 channel; –1.25 MHz frequency offset; 0 dB power Carrier 2: spread rate 1, 9 channel; 0 kHz frequency offset; 0 dB power Carrier 3: spread rate 1, 9 channel; 1.25 MHz frequency offset; 0 dB power

CDMA2000 ARB Subsystem—Option 401 ([:SOURCE]:RADIO:CDMA2000:ARB)

CAR4	This choice specifies the following standard 2-carrier setup: Carrier 1: spread rate 1, 9 channel; –1.875 MHz frequency offset; 0 dB power Carrier 2: spread rate 1, 9 channel; –625 kHz frequency offset; 0 dB power Carrier 3: spread rate 1, 9 channel; 625 kHz frequency offset; 0 dB power Carrier 4: spread rate 1, 9 channel; 1.875 MHz frequency offset; 0 dB power
*RST	CAR2
Key Entry	2 SR3 Carriers 3 Carriers 4 Carriers Custom CDMA2000 Multicarrier
Remarks	Refer to “File Name Variables” on page 13 for information on the file name syntax.

:LINK:FORWARD:SETup:MCARrier:STORE

Supported E4438C with Option 401

```
[ :SOURCE ] :RADIO:CDMA2000:ARB:LINK:FORWARD:SETup:MCARrier:
STORE "<file name>"
```

This command stores the current multicarrier setup information.

The stored file contains information including the digital modulation format, number of carriers, frequency spacing, and power settings for the multicarrier setup.

Key Entry Store Custom Multicarrier

Remarks Recall stored files from memory by executing the following command:

```
[ :SOURCE ] :RADIO:CDMA2000:ARB:LINK:FORWARD:SETup:
MCARrier "<file name>"
```

Refer to [“File Name Variables” on page 13](#) for information on the file name syntax.

:LINK:FORWARD:SETup:MCARrier:TABLE

Supported E4438C with Option 401

```
[ :SOURCE ] :RADIO:CDMA2000:ARB:LINK:FORWARD:SETup:MCARrier:TABLE INIT |
APPend |<chan_num>, S1Pilot | S3DPilot | S3MPilot | S19Chan | S3D9chan | S3M9chan |
"<file name>", <freq_offset>, <power>
[ :SOURCE ] :RADIO:CDMA2000:ARB:LINK:FORWARD:SETup:MCARrier:
TABLE? <chan_num>
```

This command defines the multicarrier CDMA2000 waveform.

CDMA2000 ARB Subsystem–Option 401 (:SOURce]:RADio:CDMA2000:ARB)

The variable <freq_offset> is expressed in units of Hertz (MHz).

The variable <power> is expressed in units of decibels (dB).

Channel type, frequency offset, and power level are returned when a query is initiated. The output format is as follows:

<channel type>, <freq_offset>, <power>

INIT	This choice clears the current information and creates a new one-row table, allowing for further definition using additional parameters.		
APPend	This choice adds rows to an existing table. The maximum number of rows for one table is 25.		
S1Pilot	This choice sets a single SR1 Pilot forward channel.		
S3DPilot	This choice sets a single direct spread pilot forward channel.		
S3MPilot	This choice sets a single SR3 multicarrier spread pilot forward channel.		
S19Chan	This choice sets a SR1 9 forward channel.		
S3D9chan	This choice sets a SR3 direct spread forward channel.		
S3M9chan	This choice sets a SR3 multicarrier spread 9 forward channel.		
*RST	channel type: S3D9CHAN	<freq_offset>: -2.50000000E+006	
		<power>: +0.00000000E+000	
Range	<freq_offset>: -15E6 to 15E6	<power>: -40 to 0	
Key Entry	Select File	Insert Row	SR1 Pilot SR3 Direct Pilot SR3 Mcarrier Pilot SR3 Mcarrier Pilot SR1 9 Channel SR3 Direct 9 Channel SR3 Mcarrier 9 Channel Custom CDMA2000 Carrier
Field Entry	Freq Offset	Power	
Remarks	Refer to “File Name Variables” on page 13 for information on the file name syntax.		

:LINK:FORward:SETup:MCARrier:TABLE:NCARriers

Supported E4438C with Option 401

[:SOURce] :RADio:CDMA2000:ARB:LINK:FORward:SETup:MCARrier:TABLE:NCARriers?

This command queries the number of carriers specified for the multicarrier CDMA2000 waveform.

***RST** +2

:LINK:FORWARD:SETup:STORe**Supported** E4438C with Option 401

[:SOURCE]:RADIO:CDMA2000:ARB:LINK:FORWARD:SETup:STORe "<file name>"

This command stores the current custom CDMA2000 state, using a designated file name, to the signal generator memory.

Along with the contents of the CDMA2000 channel table editor (channel types, Walsh code, power levels, PN offset, and data), this command stores the following information to the signal generator memory:

- FIR filter
- FIR filter file name
- FIR filter alpha
- FIR filter BbT
- FIR filter channel (EVM or ACP)
- I/Q mapping
- link
- spread type
- spread rate
- ARB reference clock source (internal or external)
- ARB reference clock frequency
- clipping
- multicarrier spacing
- radio configuration

Key Entry Store Custom CDMA State**Remarks** Recall this stored file by executing the following command:

[:SOURCE]:RADIO:CDMA2000:ARB:LINK:FORWARD:SETup "<file name>"

Refer to [“File Name Variables” on page 13](#) for information on the file name syntax.

:LINK:FORWARD:SETup:TABLE:APPLy**Supported** E4438C with Option 401

[:SOURCE]:RADIO:CDMA2000:ARB:LINK:FORWARD:SETup:TABLE:APPLy

This command generates a CDMA2000 signal based on the current values in the CDMA2000 channel setup table editor.

Key Entry Apply Channel Setup

:LINK:FORWARD:SETup:TABLE:CHANnel

Supported E4438C with Option 401

```
[:SOURce]:RADio:CDMA2000:ARB:LINK:FORWARD:SETup:TABLE:CHANnel INIT|
APPend|<chan_num>,<chan_type>,<config>,<data_rate>,<walsh>,<power>,<
pn_offset>,RANDOM|<data_val>
[:SOURce]:RADio:CDMA2000:ARB:LINK:FORWARD:SETup:TABLE:
CHANnel? <chan_num>
```

This command defines the channel parameters of the CDMA2000 signal.

The variable <power> is expressed in units of decibels (dB).

The variable <data_rate> is expressed in units bits per second (bps).

The channel type, configuration type, data rate, walsh code, power, pn offset, and data value are returned when a query is initiated. The output format is as follows:

```
<chan_type>,<config>,<data_rate>,<walsh>,<power>,<pn_offset>,<data_val>
```

INIT This choice clears the current information and creates a new one-row table, allowing for further definition using additional parameters.

APPend This choice adds rows to an existing table.

RANDom This choice selects a randomly generated data value.

<data_val> This variable specifies a specific data value.

***RST** channel type: PIL <config>: +3 <data_rate>: +3.84000000E+004
 <walsh>: +0 <power>: -7.00000000E+000 <pn_offset>: +0
 <data_val>: 0

Range <data_rate>: 1500–307200 <walsh>: 0–63 <power>: –40 to 0
 <pn_offset>: 0–511 <data_val>: 0000000–11111111

Key Entry Edit Channel Setup Insert Row Config Rate
 Walsh Code PN Offset

Remarks Queries initiated for this command must be followed by a specific channel number.

The above *RST value represents a query of channel one.

:LINK:FORWARD:SETup:TABLE:NCHannels**Supported** E4438C with Option 401

[:SOURCE]:RADIO:CDMA2000:ARB:LINK:FORWARD:SETup:TABLE:NCHannels?

This command queries the number of channels specified for the CDMA2000 link setup.

RST** +9**:LINK:FORWARD:SETup:TABLE:PADJust*Supported** E4438C with Option 401

[:SOURCE]:RADIO:CDMA2000:ARB:LINK:FORWARD:SETup:TABLE:PADJust EQUAL | SCALE

This command sets the code domain power (the relative power in each of the channels).

EQUAL Sets all channels to equal power, and the total power to 0 dB.

SCALE Scales all of the current channel powers so that the total power equals 0 dB, keeping the previous power ratios between the individual channels.

Key Entry Equal Powers Scale To 0dB**:LINK:REVERSE:RCONfig****Supported** E4438C with Option 401

[:SOURCE]:RADIO:CDMA2000:ARB:LINK:REVERSE:RCONfig <val>

[:SOURCE]:RADIO:CDMA2000:ARB:LINK:REVERSE:RCONfig?

This command sets the radio configuration for all reverse link channels.

***RST** +1**Range** 1–4**Key Entry** Radio Config**Remarks** Changing the radio configuration results in changes to the channel data rate.

:LINK:REVerse:SETup

Supported E4438C with Option 401

```
[ :SOURce ] :RADio:CDMA2000:ARB:LINK:REVerse:SETup S1Pilot | S3Pilot |  
S15Chan | S35Chan | S18Chan | "<file name>"  
[:SOURce]:RADio:CDMA2000:ARB:LINK:REVerse:SETup?
```

This command selects a previously defined channel configuration for the CDMA2000 reverse link.

S1Pilot This choice selects a spread rate 1, pilot-channel setup.

S3Pilot This choice selects a spread rate 3, pilot-channel setup.

S15Chan This choice selects a spread rate 1, 5-channel setup.

S35Chan This choice selects a spread rate 3, 5-channel setup.

S18Chan This choice selects a spread rate 1, 8-channel setup.

***RST** S15Chan

Key Entry **Pilot** **5 Channel** **8 Channel** **Custom CDMA2000 State**
Spread Rate 1 **Spread Rate 3**

Remarks Refer to [“File Name Variables” on page 13](#) for information on the file name syntax.

:LINK:REVerse:SETup:STORE

Supported E4438C with Option 401

```
[ :SOURce ] :RADio:CDMA2000:ARB:LINK:REVerse:SETup:STORE "<file name>"
```

This command stores the current custom CDMA2000 state, using a designated file name, to the signal generator memory.

Along with the contents of the CDMA2000 channel table editor (channel types, Walsh code, power levels, PN offset, and data), this command stores the following information to the signal generator memory:

- FIR filter
- FIR filter file name
- FIR filter alpha
- FIR filter BbT
- FIR filter channel (EVM or ACP)
- I/Q mapping
- link
- spread type

CDMA2000 ARB Subsystem—Option 401 (:SOURce]:RADio:CDMA2000:ARB)

spread rate
 ARB reference clock source (internal or external)
 ARB reference clock frequency
 clipping
 multicarrier spacing
 radio configuration

Key Entry **Store Custom CDMA State**

Remarks Recall this stored file by executing the following command:

```
[ :SOURce ] :RADio:CDMA2000:ARB:LINK:REVerse:
SETup "<file name>"
```

Refer to [“File Name Variables” on page 13](#) for information on the file name syntax.

:LINK:REVerse:SETup:TABLE:APPLY

Supported E4438C with Option 401

```
[ :SOURce ] :RADio:CDMA2000:ARB:LINK:REVerse:SETup:TABLE:APPLY
```

This command generates a CDMA2000 signal based on the current values in the CDMA2000 channel setup table editor.

Key Entry **Apply Channel Setup**

:LINK:REVerse:SETup:TABLE:CHANnel

Supported E4438C with Option 401

```
[ :SOURce ] :RADio:CDMA2000:ARB:LINK:REVerse:SETup:TABLE:CHANnel INIT |
APPend|<chan_num>, <chan_type>, <data_rate>, <power>, RANDOM|<data_val>
[ :SOURce ] :RADio:CDMA2000:ARB:LINK:REVerse:SETup:TABLE:
CHANnel? <chan_num>
```

This command defines the channel parameters for the CDMA2000 signal.

The channel number, configuration type, data rate, walsh code, power, pn offset, and data value are returned when a query is initiated. The output format is as follows:

```
<chan_type>,<data_rate>,<power>,<data_val>
```

The variable <data_rate> is expressed as bits per second (bps).

The variable <power> is expressed in units of decibels (dB).

INIT This choice clears the current information and creates a new one-row table, allowing for further definition using additional parameters.

CDMA2000 ARB Subsystem–Option 401 ([:SOURce]:RADio:CDMA2000:ARB)

APPend	This choice adds rows to an existing table. The maximum number of channels in a table is eight.
RANDom	This choice selects a randomly generated data value.
<data_val>	This variable customizes a specific data value.
*RST	<i>channel type</i> : PIL <i><data_rate></i> : +3.84000000E+004 <i><power></i> : -7.00000000E+000 <i><pn_offset></i> : +0 <i><data_val></i> : 0
Range	<i><data_rate></i> : 1500–9600 <i><power></i> : –40 to 0 <i><data_val></i> : 0000000–11111111
Key Entry	Edit Channel Setup Insert Row Config Rate Walsh Code PN Offset
Remarks	Queries initiated for this command must be followed by a specific channel number. The above *RST value represents a query of channel one.

:LINK:REVerse:SETup:TABLE:NCHannels

Supported	E4438C with Option 401
	[:SOURce] :RADio:CDMA2000:ARB:LINK:REVerse:SETup:TABLE:NCHannels?
	This command query returns the number of channels for the CDMA2000 link reverse setup.
*RST	+5

:LINK:REVerse:SETup:TABLE:PADJust

Supported	E4438C with Option 401
	[:SOURce] :RADio:CDMA2000:ARB:LINK:REVerse:SETup:TABLE:PADJust EQUAL SCALE
	This command customizes the code domain power (the relative power in each of the channels).
EQUAL	This choice changes all channels to equal power, and the total power to 0 dB.
SCALE	This choice scales all of the current channel powers so that the total power equals 0 dB, keeping the previous power ratios between the individual channels.
Key Entry	Equal Powers Scale To 0dB

:MDESTINATION:AAMPLITUDE**Supported** E4438C with Option 401

```
[:SOURCE]:RADIO:CDMA2000:ARB:MDESTINATION:AAMPLITUDE NONE|M1|M2|M3|M4
[:SOURCE]:RADIO:CDMA2000:ARB:MDESTINATION:AAMPLITUDE?
```

This command routes the selected marker to the Alternate Amplitude function. The NONE parameter clears the marker for the Alternate Amplitude function.

RST** NONE**Key Entry** None Marker 1 Marker 2 Marker 3 Marker 4**:MDESTINATION:ALCHOLD*Supported** E4438C with Option 401

CAUTION Incorrect automatic level control (ALC) sampling can create a sudden unlevelled condition that may create a spike in the RF output potentially damaging a DUT or connected instrument. Ensure that you set markers to let the ALC sample over an amplitude that accounts for the high power levels within the signal.

```
[:SOURCE]:RADIO:CDMA2000:ARB:MDESTINATION:ALCHOLD NONE|M1|M2|M3|M4
[:SOURCE]:RADIO:CDMA2000:ARB:MDESTINATION:ALCHOLD?
```

This command enables or disables the marker ALC hold function for the selected marker. For setting markers, see “:MARKER:[SET]” on page 306.

Use the ALC hold function when you have a waveform signal that incorporates idle periods, or when the increased dynamic range encountered with RF blanking is not desired. The ALC leveling circuitry responds to the marker signal during the marker pulse (marker signal high), averaging the modulated signal level during this period.

The ALC hold function operates during the low periods of the marker signal. The marker polarity determines when the marker signal is high. For a positive polarity, this is during the marker points. For a negative polarity, this is when there are no marker points. For setting a marker’s polarity, see “:MPOLARITY:MARKER1|2|3|4” on page 260.

NOTE Do not use the ALC hold for more than 100 ms, because it can affect the waveform’s output amplitude.

The marker signal has a minimum of a two-sample delay in its response relative to the waveform signal response. To compensate for the marker signal delay, offset marker points from the waveform sample point at which you want the ALC sampling to begin.

The ALC hold setting is part of the file header information, so saving the setting to the file header saves the current marker routing for the waveform file.

NOTE A waveform file that has unspecified settings in the file header uses the previous waveform’s routing settings.

For more information on the marker ALC hold function, see the *E4428C/38C ESG Signal Generators User’s Guide*. For setting the marker points, see “:MARKer:[SET]” on page 306.

- NONE This terminates the marker ALC hold function.
- M1–M4 These are the marker choices. The ALC hold feature uses only one marker at a time.
- *RST NONE

Example

```
:RAD:AWGB:ARB:MDES:ALCH M1
```

The preceding example routes marker 1 to the ALC Hold function.

Key Entry	None	Marker 1	Marker 2	Marker 3	Marker 4
Remarks	N/A				

:MDEStination:PULSe

Supported E4438C with Option 401

CAUTION The pulse function incorporates ALC hold. Incorrect automatic level control (ALC) sampling can create a sudden unlevelled condition that may create a spike in the RF output potentially damaging a DUT or connected instrument. Ensure that you set markers to let the ALC sample over an amplitude that accounts for the high power levels within the signal.

```
[ :SOURce ] :RADio:CDMA2000:ARB:MDEStination:PULSe NONE | M1 | M2 | M3 | M4
[ :SOURce ] :RADio:CDMA2000:ARB:MDEStination:PULSe?
```

This command enables or disables the marker pulse/RF blanking function for the selected marker.

This function automatically uses the ALC hold function, so there is no need to select both the ALC hold and pulse/RF blanking functions for the same marker.

NOTE Do not use ALC hold for more than 100 ms, because it can affect the waveform’s output amplitude.

The signal generator blanks the RF output when the marker signal goes low. The marker polarity determines when the marker signal is low. For a positive polarity, this is during the marker points. For a negative polarity, this is when there are no marker points. For setting a marker’s polarity, see “:MPOLarity:MARKer1|2|3|4” on page 260.

NOTE Set marker points prior to using this function. Enabling this function without setting marker points may create a continuous low or high marker signal, depending on the marker polarity. This causes either no RF output or a continuous RF output. See “:MARKer:[SET]” on page 306 for setting the marker points.

The marker signal has a minimum of a two-sample delay in its response relative to the waveform signal response. To compensate for the marker signal delay, offset marker points from the waveform sample point at which you want the RF blanking to begin. The RF blanking setting is part of the file header information, so saving the setting to the file header saves the current marker routing for the waveform file.

NOTE A waveform file that has unspecified settings in the file header uses the previous waveform’s routing settings. This could create the situation where there is no RF output signal, because the previous waveform used RF blanking.

For more information on the marker RF blanking function, see the *E4428C/38C ESG Signal Generators User’s Guide*.

NONE This terminates the marker RF blanking/pulse function.

M1–M4 These are the marker choices. The RF blanking/pulse feature uses only one marker at a time.

Example

```
:RAD:ARB:MDES:PULS M2
```

The preceding example routes marker 2 to Pulse/RF Blanking.

```
*RST NONE
```

Key Entry **None** **Marker 1** **Marker 2** **Marker 3** **Marker 4**

:MPOLarity:MARKer1|2|3|4

Supported E4438C with Option 401

```
[:SOURce]:RADio:CDMA2000:ARB:MPOLarity:MARKer1|2|3|4 NEGative|POSitive
[:SOURce]:RADio:CDMA2000:ARB:MPOLarity:MARKer1|2|3|4?
```

This command sets the polarity for the selected marker. For a positive marker polarity, the marker signal is high during the marker points. For a negative marker polarity, the marker signal is high during the period of no marker points.

***RST** POS

Key Entry	Marker 1 Polarity Neg	Marker 2 Polarity Neg	Marker 3 Polarity Neg
	Pos	Pos	Pos
	Marker 4 Polarity Neg Pos		

:REFerence:EXTernal:FREQuency

Supported E4438C with Option 401

```
[:SOURce]:RADio:CDMA2000:ARB:REFerence:EXTernal:FREQuency <val>
[:SOURce]:RADio:CDMA2000:ARB:REFerence:EXTernal:FREQuency?
```

This command allows you to enter the frequency of the applied external reference.

The variable <val> is expressed in units of Hertz (KHz–MHz).

***RST** +1.00000000E+007

Range 2.5E5–1E8

Key Entry Reference Freq

Remarks The value specified by this command is effective only when you are using an external ARB reference applied to the BASEBAND GEN REF IN rear panel connector.

To specify external as the ARB reference source type, refer to “:REFerence[:SOURce]” on page 260.

:REFerence[:SOURce]

Supported E4438C with Option 401

```
[:SOURce]:RADio:CDMA2000:ARB:REFerence[:SOURce] INTernal|EXTernal
[:SOURce]:RADio:CDMA2000:ARB:REFerence[:SOURce]?
```

This command selects either an internal or external reference for the waveform clock.

CDMA2000 ARB Subsystem–Option 401 (:SOURce]:RADIo:CDMA2000:ARB)

*RST	INT
Key Entry	ARB Reference Ext Int
Remarks	<p>If the EXTERNAL choice is selected, the external frequency value <i>must</i> be entered and the signal must be applied to the BASEBAND GEN REF IN rear panel connector.</p> <p>Refer to “:REFERENCE:EXTERNAL:FREQUENCY” on page 260 to enter the external reference frequency.</p>

:RETRigger

Supported	E4438C with Option 401
	[:SOURce] :RADIo:CDMA:ARB:RETRigger ON OFF IMMEDIATE
	[:SOURce] :RADIo:CDMA:ARB:RETRigger?

This command enables or disables the ARB retriggering mode; the retrigger mode controls how the retriggering function performs while a waveform is playing.

ON (1)	This choice specifies that if a trigger occurs while a waveform is playing, the waveform will retrigger at the end of the current waveform sequence and play once more.
OFF (0)	This choice specifies that if a trigger occurs while a waveform is playing, the trigger will be ignored.
IMMEDIATE	This choice specifies that if a trigger occurs while a waveform is playing, the waveform will reset and replay from the start immediately upon receiving a trigger.

*RST	ON
Key Entry	On Off Immediate

:REVISION

Supported	E4438C with Option 401
	[:SOURce] :RADIo:CDMA2000:ARB:REVISION?

This command queries the revision number of the current CDMA2000 format.

*RST	8
-------------	---

:SCLock:RATE

Supported E4438C with Option 401

[:SOURce] :RADio:CDMA2000:ARB:SCLock:RATE <val>

[:SOURce] :RADio:CDMA2000:ARB:SCLock:RATE?

This command sets the sample clock rate for the CDMA2000 modulation format.

The variable <val> is expressed in units of hertz.

***RST** +1.00000000E+008

Range 1–1E8

Key Entry ARB Sample Clock

Remarks The modulation format should be active before executing this command. If this command is executed before the modulation format is active, the entered value will be overridden by a calculated factory default value. Refer to “[:STATe]” on [page 269](#) to activate the modulation format.

:SPReading:RATE

Supported E4438C with Option 401

[:SOURce] :RADio:CDMA2000:ARB:SPReading:RATE 1 | 3

[:SOURce] :RADio:CDMA2000:ARB:SPReading:RATE?

This command opens a submenu that provides the available spread rate choices for the CDMA2000 waveform.

***RST** +1

Key Entry Spread Rate 1 Spread Rate 3

Remarks The spread rate multiplied by 1.2288 MHz is equal to the chip rate. For example, spread rate 3 equals a 3.6864 Mcps chip rate.

Higher data rates can be achieved using spread rate 3, though offset by greater bandwidth/spectrum usage.

Changing the spread rate to either 1 or 3 will also change the initial setup menu, resulting in a configuration that is specific to the current spread rate.

:SPReading:TYPE**Supported** E4438C with Option 401[:SOURCE]:RADIO:CDMA2000:ARB:SPReading:TYPE DIRECT | MCarriER
[:SOURCE]:RADIO:CDMA2000:ARB:SPReading:TYPE?

This command selects the spreading type for a CDMA2000 waveform.

***RST** DIR**Key Entry** Spreading Type Direct Mcarrier**Remarks** Multicarrier is not available in the reverse link setup.

Note that changing the spreading type will result in the setup changing to a setup for the current spreading type.

:SPReading:TYPE:MCARrier:SPACing**Supported** E4438C with Option 401[:SOURCE]:RADIO:CDMA2000:ARB:SPReading:TYPE:MCARrier:SPACing 1.23MHz |
1.25MHz
[:SOURCE]:RADIO:CDMA2000:ARB:SPReading:TYPE:MCARrier:SPACing?

This command selects the multicarrier frequency spacing.

RST** +1.25000000E+006**Key Entry** 1.23 MHz 1.25 MHz**Remarks** Cellular band uses 1.23 MHz and PCS band uses 1.25 MHz.**:TRIGger:TYPE*Supported** E4438C with Option 401[:SOURCE]:RADIO:CDMA2000:ARB:TRIGger:TYPE CONTinuous | SINGLE | GATE
[:SOURCE]:RADIO:CDMA2000:ARB:TRIGger:TYPE?**:TRIGger:TYPE****Supported** E4438C with Option 401[:SOURCE]:RADIO:CDMA:ARB:TRIGger:TYPE CONTinuous | SINGLE | GATE
[:SOURCE]:RADIO:CDMA:ARB:TRIGger:TYPE?

This command sets the trigger mode (type) that controls the waveform's playback.

Triggers control the playback by telling the ESG when to play the modulating signal (waveform). Depending on the trigger settings for the ESG, the waveform playback can occur once, continuously, or the ESG may start and stop playing the waveform repeatedly (GATE mode).

A trigger signal comprises both positive and negative signal transitions (states), which are also called high and low periods. You can configure the ESG to trigger on either state of the trigger signal. It is common to have multiple triggers, also referred to as trigger occurrences or events, occur when the signal generator requires only a single trigger. In this situation, the ESG recognizes the first trigger and ignores the rest.

When you select a trigger mode, you may lose the signal (carrier plus modulating) from the RF output until you trigger the waveform. This is because the ESG sets the I and Q signals to zero volts prior to the first trigger event, which suppresses the carrier. After the first trigger event, the waveform's final I and Q levels determine whether you will see the carrier signal or not (zero = no carrier, other values = carrier visible). At the end of most files, the final I and Q points are set to a value other than zero.

There are four parts to configuring the trigger:

- Choosing the trigger type, which controls the waveform's transmission.
- Setting the waveform's response to triggers:
 - CONTInuous, see [“:TRIGger:TYPE:CONTInuous\[:TYPE\]”](#) on page 265
 - SINGle, see [“:RETRigger”](#) on page 261
 - GATE, selecting the mode also sets the response
- Selecting the trigger source (see [“:TRIGger\[:SOURce\]”](#) on page 266), which determines how the ESG receives its trigger signal, internally or externally. The GATE choice requires an external trigger.
- Setting the trigger polarity when using an external source:
 - CONTInuous and SINGle see [“:TRIGger\[:SOURce\]:EXTErnal:SLOPe”](#) on page 268
 - GATE, see [“:TRIGger:TYPE:GATE:ACTive”](#) on page 266

For more information on triggering, see the *E4428C/38C ESG Signal Generators User's Guide*.

The following list describes the trigger type command choices:

CONTInuous	Upon triggering, the waveform repeats continuously.
SINGle	Upon triggering, the waveform segment or sequence plays once.

GATE An external trigger signal repeatedly starts and stops the waveform’s playback (transmission). The time duration for playback depends on the duty period of the trigger signal and the gate polarity selection (see “:TRIGger:TYPE:GATE:ACTive” on page 266). The waveform plays during the inactive state and stops during the active polarity selection state. The active state can be set high or low. The gate mode works only with an external trigger source.

NOTE The ARB gating behavior described above is opposite to the gating behavior for real-time custom mode.

***RST** CONT
Key Entry Continuous Single Gated

:TRIGger:TYPE:CONTInuous[:TYPE]

Supported E4438C with Option 401

```
[ :SOURCE ] :RADio:CDMA2000:ARB:TRIGger:TYPE:CONTInuous [ :TYPE ] FREE |
TRIGger | RESet
[ :SOURCE ] :RADio:CDMA2000:ARB:TRIGger:TYPE:CONTInuous [ :TYPE ] ?
```

This commands selects the waveform’s response to a trigger signal while using the continuous trigger mode.

For more information on triggering and to select the continuous trigger mode, see “:TRIGger:TYPE” on page 263.

The following list describes the waveform’s response to each of the command choices:

FREE Turning the ARB format on immediately triggers the waveform. The waveform repeats until you turn the format off, select another trigger, or choose another waveform file.

TRIGger The waveform waits for a trigger before play begins. When the waveform receives the trigger, it plays continuously until you turn the format off, select another trigger, or choose another waveform file.

RESet The waveform waits for a trigger before play begins. When the waveform receives the trigger, it plays continuously. Subsequent triggers reset the waveform to the beginning. For a waveform sequence, this means to the beginning of the first segment in the sequence.

***RST** FREE
Key Entry Free Run Trigger & Run Reset & Run

:TRIGger:TYPE:GATE:ACTive

Supported E4438C with Option 401

```
[:SOURce]:RADio:CDMA2000:ARB:TRIGger:TYPE:GATE:ACTive LOW|HIGH
[:SOURce]:RADio:CDMA2000:ARB:TRIGger:TYPE:GATE:ACTive?
```

This command selects the active state (gate polarity) of the gate while using the gating trigger mode.

The LOW and HIGH selections correspond to the low and high states of an external trigger signal. For example, when you select HIGH, the active state occurs during the high of the trigger signal. When the active state occurs, the ESG stops the waveform playback at the last played sample point, then restarts the playback at the next sample point when the inactive state occurs. For more information on triggering and to select gating as the trigger mode, see “:TRIGger:TYPE” on page 263.

The following list describes the ESG’s gating behavior for the polarity selections:

- LOW The waveform playback stops when the trigger signal goes low (active state) and restarts when the trigger signal goes high (inactive state).
- HIGH The waveform playback stops when the trigger signal goes high (active state) and restarts when the trigger signal goes low (inactive state).
- *RST HIGH

Key Entry Gate Active Low High

:TRIGger[:SOURce]

Supported E4438C with Option 401

```
[:SOURce]:RADio:CDMA2000:ARB:TRIGger[:SOURce] KEY|EXT|BUS
[:SOURce]:RADio:CDMA2000:ARB:TRIGger[:SOURce]?
```

This command sets the trigger source.

For more information on triggering, see “:TRIGger:TYPE” on page 263. The following list describes the command choices:

- KEY This choice enables manual triggering by pressing the front-panel **Trigger** hardkey.
- EXT An externally applied signal triggers the waveform. This is the only choice that works with gating. The following conditions affect an external trigger:
 - The input connector selected for the trigger signal. You have a choice between the rear-panel PATTERN TRIG IN connector or the PATT TRIG IN 2 pin on the rear-panel AUXILIARY I/O connector. To make the connector selection, see “:TRIGger[:SOURce]:EXTernal[:SOURce]” on page 269.

For more information on the connectors and on connecting the cables, see the *E4428C/38C ESG Signal Generators User's Guide*.

- The trigger signal polarity:
 - gating mode, see “:TRIGger:TYPE:GATE:ACTive” on page 266
 - continuous and single modes, see “:TRIGger[:SOURCE]:EXTernal:SLOPe” on page 268
- The time delay between when the ESG receives a trigger and when the waveform responds to the trigger. There are two parts to setting the delay:
 - setting the amount of delay, see “:TRIGger[:SOURCE]:EXTernal:DELay” on page 267
 - turning the delay on, see “:TRIGger[:SOURCE]:EXTernal:DELay:STATe” on page 268

BUS This choice enables triggering over the GPIB or LAN using the *TRG or GET commands or the AUXILIARY INTERFACE (RS-232) using the *TRG command.

***RST** EXT

Key Entry Trigger Key Ext Bus

:TRIGger[:SOURCE]:EXTernal:DELay

Supported E4438C with Option 401

```
[ :SOURCE ] : RADIo : CDMA2000 : ARB : TRIGger [ : SOURCE ] : EXTernal : DELay <val>
[ : SOURCE ] : RADIo : CDMA2000 : ARB : TRIGger [ : SOURCE ] : EXTernal : DELay?
```

This command sets the amount of time to delay the ESG's response to an external trigger.

The delay is a path (time) delay between when the ESG receives the trigger and when it responds to the trigger. For example, configuring a trigger delay of two seconds, causes the ESG to wait two seconds after receipt of the trigger before the ESG plays the waveform.

The delay does not occur until you turn it on (see “:TRIGger[:SOURCE]:EXTernal:DELay:STATe” on page 268). You can set the delay value either before or after turning it on.

For more information on configuring an external trigger source and to select external as the trigger source, see “:TRIGger[:SOURCE]” on page 266.

The unit of measurement for the variable <val> is in seconds (nsec–sec).

***RST** +1.00000000E–003

CDMA2000 ARB Subsystem–Option 401 (:SOURce):RADio:CDMA2000:ARB)

Range 1E–8 to 4E1

Key Entry Ext Delay Time

:TRIGger[:SOURce]:EXTeRnal:DELAy:STATe

Supported E4438C with Option 401

```
[ :SOURce ] :RADio:CDMA2000:ARB:TRIGger [ :SOURce ] :EXTeRnal:DELAy:STATe ON | OFF | 1 | 0
[ :SOURce ] :RADio:CDMA2000:ARB:TRIGger [ :SOURce ] :EXTeRnal:DELAy:STATe?
```

This command enables or disables the operating state of the external trigger delay function.

For setting the delay time, see “:TRIGger[:SOURce]:EXTeRnal:DELAy” on page 267, and for more information on configuring an external source, see “:TRIGger[:SOURce]” on page 266.

***RST** 0

Key Entry Ext Delay Off On

:TRIGger[:SOURce]:EXTeRnal:SLOPe

Supported E4438C with Option 401

```
[ :SOURce ] :RADio:CDMA2000:ARB:TRIGger [ :SOURce ] :EXTeRnal:SLOPe POSitive | NEGative
[ :SOURce ] :RADio:CDMA2000:ARB:TRIGger [ :SOURce ] :EXTeRnal:SLOPe?
```

This command sets the polarity for an external trigger signal while using the continuous, single triggering mode. To set the polarity for gating, see “:TRIGger:TYPE:GATE:ACTive” on page 266.

The POSitive and NEGative selections correspond to the high (positive) and low (negative) states of the external trigger signal. For example, when you select POSitive, the waveform responds (plays) during the high state of the trigger signal. When the ESG receives multiple trigger occurrences when only one is required, the signal generator uses the first trigger and ignores the rest.

For more information on configuring an external trigger source and to select external as the trigger source, see “:TRIGger[:SOURce]” on page 266.

***RST** NEG

Key Entry Ext Polarity Neg Pos

:TRIGger[:SOURce]:EXTernal[:SOURce]**Supported** E4438C with Option 401

```
[:SOURce]:RADio:CDMA2000:ARB:TRIGger[:SOURce]:EXTernal[:SOURce] EPT1 |
EPT2 | EPTRIGGER1 | EPTRIGGER2
[:SOURce]:RADio:CDMA2000:ARB:TRIGger[:SOURce]:EXTernal[:SOURce] ?
```

This command selects which PATTERN TRIG IN connection the ESG uses to accept an externally applied trigger signal when external is the trigger source selection.

For more information on configuring an external trigger source and to select external as the trigger source, see “:TRIGger[:SOURce]” on page 266. For more information on the rear-panel connectors, see the *E4428C/38C ESG Signal Generators User’s Guide*.

The following list describes the command choices:

EPT1	This choice is synonymous with EPTRIGGER1 and selects the PATTERN TRIG IN rear-panel connector.
EPT2	This choice is synonymous with EPTRIGGER2 and selects the PATT TRIG IN 2 pin on the rear-panel AUXILIARY I/O connector.
EPTRIGGER1	This choice is synonymous with EPT1 and selects the PATTERN TRIG IN rear-panel connector.
EPTRIGGER2	This choice is synonymous with EPT2 and selects the PATT TRIG IN 2 pin on the rear-panel AUXILIARY I/O connector.
*RST	EPT1
Key Entry	Patt Trig In 1 Patt Trig In 2

[:STATE]**Supported** E4438C with Option 401

```
[:SOURce]:RADio:CDMA2000:ARB[:STATE] ON|OFF|1|0
[:SOURce]:RADio:CDMA2000:ARB[:STATE] ?
```

This command enables or disables the CDMA2000 modulation format.

ON (1)	This choice enables the CDMA2000 modulation capability and sets up the internal hardware to generate the currently selected CDMA2000 signal selection. This choice also activates the I/Q state and sets the I/Q source to internal.
OFF (0)	This choice disables the CDMA2000 baseband signal capability.
*RST	0
Key Entry	CDMA2000 Off On

Dmodulation Subsystem–Option 001/601 or 002/602 ([:SOURce]:RADio:DMODulation:ARB)

:IQ:EXTernal:FILTer

Supported E4438C with Option 001/601 or 002/602

```
[:SOURce]:RADio:DMODulation:ARB:IQ:EXTernal:FILTer 40e6|THROUGH
```

```
[:SOURce]:RADio:DMODulation:ARB:IQ:EXTernal:FILTer?
```

This command selects the filter or through path for I/Q signals routed to the rear panel I and Q outputs. Selecting a filter using this command will automatically set “:IQ:EXTernal:FILTer:AUTO” on [page 270](#) to OFF(0) mode.

40e6 This choice applies a 40 MHz baseband filter.

THROUGH This choice bypasses filtering.

***RST** THR

Key Entry 40.000 MHz Through

:IQ:EXTernal:FILTer:AUTO

Supported E4438C with Option 001/601 or 002/602

```
[:SOURce]:RADio:DMODulation:ARB:IQ:EXTernal:FILTer:AUTO ON|OFF|1|0
```

```
[:SOURce]:RADio:DMODulation:ARB:IQ:EXTernal:FILTer:AUTO?
```

This command enables or disables the automatic selection of the filters for I/Q signals routed to the rear panel I/Q outputs.

ON(1) This choice will automatically select a digital modulation filter optimized for the current signal generator settings.

OFF(0) This choice disables the auto feature which lets you select a digital modulation filter or through path. Refer to “:IQ:EXTernal:FILTer” on [page 270](#) for selecting a filter or through path.

***RST** 1

Key Entry I/Q Output Filter Manual Auto

Dmodulation Subsystem—Option 001/601 or 002/602 (:SOURce):RADio:DMODulation:ARB)**:FILTer**

Supported E4438C with Option 001/601 or 002/602

```
[ :SOURce ] :RADio:DMODulation:ARB:FILTer RNYQuist | NYQuist | GAUSSian |
RECTangle | IS95 | IS95_EQ | IS95_MOD | IS95_MOD_EQ | WCDMa | AC4Fm | IS2000SR3DS |
UGGaussian | "<user FIR>"
[ :SOURce ] :RADio:DMODulation:ARB:FILTer?
```

This command specifies the pre-modulation filter type.

IS95	This choice selects a filter that meets the criteria of the IS-95 standard.																		
IS95_EQ	This choice selects a filter which is a combination of the IS-95 filter (above) and the equalizer filter described in the IS-95 standard. This filter is only used for IS-95 baseband filtering.																		
IS95_MOD	This choice selects a filter that meets the criteria of the IS-95 error function (for improved adjacent channel performance) with lower passband rejection than the filter specified in the IS-95 standard.																		
IS95_MOD_EQ	This choice selects a filter which is a combination of the equalizer filter described in the IS-95 standard and a filter that meets the criteria of the IS-95 error function (for improved adjacent channel performance), with lower passband rejection.																		
WCDMa	This choice selects a 0.22 Nyquist filter optimized for ACP.																		
AC4Fm	This choice selects a predefined Association of Public Safety Communications Officials (APCO) specified compatible 4-level frequency modulation (C4FM) filter.																		
IS2000SR3DS	This choice selects an IS-2000 standard, spread rate 3 direct spread filter.																		
UGGaussian	This choice selects a backwards compatible GSM Gaussian filter (Gaussian filter with a fixed BbT value of 0.300) for the ESG E44xxB Option UN3 or UN4.																		
"<user FIR>"	This variable is any FIR filter file that you have stored in memory. The variable needs no directory path indicating the location of the file, such as FIR: or /USER/FIR. The command assumes the FIR directory. Refer to “File Name Variables” on page 13 for more information on file names.																		
*RST	RNYQ																		
Key Entry	<table> <tbody> <tr> <td>Root Nyquist</td> <td>Nyquist</td> <td>Gaussian</td> <td>Rectangle</td> <td>IS-95</td> <td>IS-95 w/EQ</td> </tr> <tr> <td>IS-95 Mod</td> <td>IS-95 Mod w/EQ</td> <td>WCDMA</td> <td>IS-2000 SR3 DS</td> <td>APCO 25 C4FM</td> <td></td> </tr> <tr> <td>UN3/4 GSM Gaussian</td> <td>User FIR</td> <td></td> <td></td> <td></td> <td></td> </tr> </tbody> </table>	Root Nyquist	Nyquist	Gaussian	Rectangle	IS-95	IS-95 w/EQ	IS-95 Mod	IS-95 Mod w/EQ	WCDMA	IS-2000 SR3 DS	APCO 25 C4FM		UN3/4 GSM Gaussian	User FIR				
Root Nyquist	Nyquist	Gaussian	Rectangle	IS-95	IS-95 w/EQ														
IS-95 Mod	IS-95 Mod w/EQ	WCDMA	IS-2000 SR3 DS	APCO 25 C4FM															
UN3/4 GSM Gaussian	User FIR																		

:FILTer:ALPHa

Supported E4438C with Option 001/601 or 002/602

```
[ :SOURce ] :RADio:DMODulation:ARB:FILTer:ALPHa <val>
```

```
[ :SOURce ] :RADio:DMODulation:ARB:FILTer:ALPHa?
```

This command changes the Nyquist or root Nyquist filter alpha value.

The filter alpha value can be set to the minimum level (0), the maximum level (1), or in between by using fractional numeric values (0.001–0.999).

***RST** +3.50000000E–001

Range 0.000–1.000

Key Entry **Filter Alpha**

Remarks To change the current filter type, refer to “:FILTer” on page 271.

:FILTer:BBT

Supported E4438C with Option 001/601 or 002/602

```
[ :SOURce ] :RADio:DMODulation:ARB:FILTer:BBT <val>
```

```
[ :SOURce ] :RADio:DMODulation:ARB:FILTer:BBT?
```

This command changes the bandwidth-multiplied-by-bit-time (BbT) filter parameter.

The filter BbT value can be set to the minimum level (0), the maximum level (1), or in between by using fractional numeric values (0.001–0.999).

***RST** +5.00000000E–001

Range 0.000–1.000

Key Entry **Filter BbT**

Remarks This command is effective only after choosing a Gaussian filter. It does not have an effect on other types of filters.

To change the current filter type, refer to “:FILTer” on page 271.

Dmodulation Subsystem–Option 001/601 or 002/602 ([:SOURCE]:RADio:DMODulation:ARB)**:FILTer:CHANnel**

Supported E4438C with Option 001/601 or 002/602

[:SOURCE] :RADio:DMODulation:ARB:FILTer:CHANnel EVM|ACP

[:SOURCE] :RADio:DMODulation:ARB:FILTer:CHANnel?

This command optimizes the Nyquist and root Nyquist filters to minimize error vector magnitude (EVM) or to minimize adjacent channel power (ACP).

EVM This choice provides the most ideal passband.

ACP This choice improves stopband rejection.

***RST** EVM

Key Entry **Optimize FIR For EVM ACP**

Remarks To change the current filter type, refer to “:FILTer” on page 271.

:HEADer:CLEar

Supported E4438C with Option 001/601 or 002/602

[:SOURCE] :RADio:DMODulation:ARB:HEADer:CLEar

This command clears the header information from the file header used by this modulation format.

Key Entry **Clear Header**

Remarks The **Digital Modulation Off On** softkey must be set to On for this command to function.

:HEADer:SAVE

Supported E4438C with Option 001/601 or 002/602

[:SOURCE] :RADio:DMODulation:ARB:HEADer:SAVE

This command saves the header information to the file header used by this modulation format.

Key Entry **Save Setup To Header**

Remarks The **Digital Modulation Off On** softkey must be set to On for this command to function.

Dmodulation Subsystem—Option 001/601 or 002/602 (:SOURce):RADio:DMODulation:ARB)

:IQ:MODulation:ATTen

Supported E4438C with Option 001/601 or 002/602

[:SOURce] :RADio:DMODulation:ARB:IQ:MODulation:ATTen <val>

[:SOURce] :RADio:DMODulation:ARB:IQ:MODulation:ATTen?

This command sets the attenuation level of the I/Q signals being modulated through the signal generator RF path.

The variable <val> is expressed in units of decibels (dB).

***RST** +2.00000000E+000

Range 0–40

Key Entry Modulator Atten Manual Auto

:IQ:MODulation:ATTen:AUTO

Supported E4438C with Option 001/601 or 002/602

[:SOURce] :RADio:DMODulation:ARB:IQ:MODulation:ATTen:AUTO ON|OFF|1|0

[:SOURce] :RADio:DMODulation:ARB:IQ:MODulation:ATTen:AUTO?

This command enables or disables the I/Q attenuation auto mode.

ON (1) This choice enables the attenuation auto mode which optimizes the modulator attenuation for the current conditions.

OFF (0) This choice holds the attenuator at its current setting or at a selected value. Refer to “:IQ:MODulation:ATTen” on page 207 for setting the attenuation value.

***RST** 1

Key Entry Modulator Atten Manual Auto

Dmodulation Subsystem—Option 001/601 or 002/602 (:SOURce):RADio:DMODulation:ARB)**:IQ:MODulation:FILTer**

Supported E4438C with Option 001/601 or 002/602

```
[ :SOURce ] :RADio:DMODulation:ARB:IQ:MODulation:FILTer 2.1e6 | 40e6 | THROugh
[ :SOURce ] :RADio:DMODulation:ARB:IQ:MODulation:FILTer?
```

This command enables you to select a filter or through path for I/Q signals modulated onto the RF carrier. Selecting a filter using this command will automatically set “:IQ:MODulation:FILTer:AUTO” on page 275 to OFF(0) mode.

2.1E6 This choice applies a 2.1 MHz baseband filter to the I/Q signals.

40E6 This choice applies a 40 MHz baseband filter to the I/Q signals.

THROugh This choice bypasses filtering.

***RST** THR

Key Entry 2.100 MHz 40.000 MHz Through

:IQ:MODulation:FILTer:AUTO

Supported E4438C with Option 001/601 or 002/602

```
[ :SOURce ] :RADio:DMODulation:ARB:IQ:MODulation:FILTer:AUTO ON | OFF | 1 | 0
[ :SOURce ] :RADio:DMODulation:ARB:IQ:MODulation:FILTer:AUTO?
```

This command enables or disables the automatic selection of the filters for I/Q signals modulated onto the RF carrier.

ON(1) This choice will automatically select a digital modulation filter.

OFF(0) This choice disables the auto feature which lets you select a digital modulation filter or through path. Refer to “:IQ:MODulation:FILTer” on page 275 for selecting a filter or through path.

***RST** 1

Key Entry I/Q Mod Filter Manual Auto

:MDEStination:AAMPlitude

Supported E4438C with Option 001/601 or 002/602

```
[:SOURce]:RADio:DMODulation:ARB:MDEStination:AAMPlitude NONE | M1 | M2 | M3 | M4
[:SOURce]:RADio:DMODulation:ARB:MDEStination:AAMPlitude?
```

This command routes the selected marker to the Alternate Amplitude function. The NONE parameter clears the marker for the Alternate Amplitude function.

***RST** NONE

Key Entry None Marker 1 Marker 2 Marker 3 Marker 4

:MDEStination:ALCHold

Supported E4438C with Option 403

CAUTION Incorrect automatic level control (ALC) sampling can create a sudden unlevelled condition that may create a spike in the RF output potentially damaging a DUT or connected instrument. Ensure that you set markers to let the ALC sample over an amplitude that accounts for the high power levels within the signal.

```
[:SOURce]:RADio:DMODulation:ARB:MDEStination:ALCHold NONE | M1 | M2 | M3 | M4
[:SOURce]:RADio:DMODulation:ARB:MDEStination:ALCHold?
```

This command enables or disables the marker ALC hold function for the selected marker. For setting markers, see “[:MARKer]:[SET]” on page 306.

Use the ALC hold function when you have a waveform signal that incorporates idle periods, or when the increased dynamic range encountered with RF blanking is not desired. The ALC leveling circuitry responds to the marker signal during the marker pulse (marker signal high), averaging the modulated signal level during this period.

The ALC hold function operates during the low periods of the marker signal. The marker polarity determines when the marker signal is high. For a positive polarity, this is during the marker points. For a negative polarity, this is when there are no marker points. For setting a marker’s polarity, see “[:MPOlarity]:MARKer1|2|3|4” on page 280.

NOTE Do not use the ALC hold for more than 100 ms, because it can affect the waveform’s output amplitude.

The marker signal has a minimum of a two-sample delay in its response relative to the waveform signal response. To compensate for the marker signal delay, offset marker points from the waveform sample point at which you want the ALC sampling to begin.

Dmodulation Subsystem—Option 001/601 or 002/602 ([:SOURCE]:RADio:DMODulation:ARB)

The ALC hold setting is part of the file header information, so saving the setting to the file header saves the current marker routing for the waveform file.

NOTE A waveform file that has unspecified settings in the file header uses the previous waveform's routing settings.

For more information on the marker ALC hold function, see the *E4428C/38C ESG Signal Generators User's Guide*. For setting the marker points, see “:MARKer:[SET]” on page 306.

NONE This terminates the marker ALC hold function.

M1–M4 These are the marker choices. The ALC hold feature uses only one marker at a time.

***RST** NONE

Example

```
:RAD:AWGB:ARB:MDES:ALCH M1
```

The preceding example routes marker 1 to the ALC Hold function.

Key Entry	None	Marker 1	Marker 2	Marker 3	Marker 4
-----------	------	-------------	-------------	-------------	----------

Remarks	N/A
---------	-----

:MDEStination:PULSe

Supported E4438C with Option 001/601 or 002/602

CAUTION The pulse function incorporates ALC hold. Incorrect automatic level control (ALC) sampling can create a sudden unlevelled condition that may create a spike in the RF output potentially damaging a DUT or connected instrument. Ensure that you set markers to let the ALC sample over an amplitude that accounts for the high power levels within the signal.

```
[[:SOURCE]:RADio:DMODulation:ARB:MDEStination:PULSe NONE | M1 | M2 | M3 | M4  
[:SOURCE]:RADio:DMODulation:ARB:MDEStination:PULSe?
```

This command enables or disables the marker pulse/RF blanking function for the selected marker.

This function automatically uses the ALC hold function, so there is no need to select both the ALC hold and pulse/RF blanking functions for the same marker.

NOTE Do not use ALC hold for more than 100 ms, because it can affect the waveform’s output amplitude.

The signal generator blanks the RF output when the marker signal goes low. The marker polarity determines when the marker signal is low. For a positive polarity, this is during the marker points. For a negative polarity, this is when there are no marker points. For setting a marker’s polarity, see “:MPOLarity:MARKer1|2|3|4” on page 280.

NOTE Set marker points prior to using this function. Enabling this function without setting marker points may create a continuous low or high marker signal, depending on the marker polarity. This causes either no RF output or a continuous RF output. See “:MARKer:[SET]” on page 306 for setting the marker points.

The marker signal has a minimum of a two-sample delay in its response relative to the waveform signal response. To compensate for the marker signal delay, offset marker points from the waveform sample point at which you want the RF blanking to begin. The RF blanking setting is part of the file header information, so saving the setting to the file header saves the current marker routing for the waveform file.

NOTE A waveform file that has unspecified settings in the file header uses the previous waveform’s routing settings. This could create the situation where there is no RF output signal, because the previous waveform used RF blanking.

For more information on the marker RF blanking function, see the *E4428C/38C ESG Signal Generators User’s Guide*.

- NONE This terminates the marker RF blanking/pulse function.
- M1–M4 These are the marker choices. The RF blanking/pulse feature uses only one marker at a time.

Example

```
:RAD:ARB:MDES:PULS M2
```

The preceding example routes marker 2 to Pulse/RF Blanking.

```
*RST NONE
```

Key Entry None **Marker 1** **Marker 2** **Marker 3** **Marker 4**

Dmodulation Subsystem—Option 001/601 or 002/602 ([:SOURce]:RADio:DMODulation:ARB)**:MODulation:FSK[:DEViation]**

Supported E4438C with Option 001/601 or 002/602

```
[ :SOURce ] :RADio:DMODulation:ARB:MODulation:FSK[:DEViation] <val>
```

```
[ :SOURce ] :RADio:DMODulation:ARB:MODulation:FSK[:DEViation] ?
```

This command sets the symmetric FSK frequency deviation value.

The variable <val> is expressed in units of Hertz and the maximum range value equals the current symbol rate value multiplied by ten, limited to 20 MHz.

***RST** +4.00000000E+002

Range 0–2E7

Key Entry **Freq Dev**

Remarks To change the modulation type, refer to “:MODulation[:TYPE]” on page 279.

Refer to “:SRATe” on page 286 for a list of the minimum and maximum symbol rate values.

To set an asymmetric FSK deviation value, refer to the *E4428C/38C ESG Signal Generators User’s Guide* for more information.

:MODulation[:TYPE]

Supported E4438C with Option 001/601 or 002/602

```
[ :SOURce ] :RADio [ 1 | 2 | 3 | 4 :DMODulation:ARB:MODulation[:TYPE] ASK|BPSK|QPSK
|UQPSk|IS95QPSK|GRAYQPSK|OQPSK|IS95OQPSK|P4DQPSK|PSK8|PSK16|D8PSK|EDGE|M
SK|FSK2|FSK4|FSK8|FSK16|C4FM|HCPM|HDQPSK|QAM4|QAM16|QAM32|QAM64|QAM128|Q
AM256|UIQ|UFSK
```

```
[ :SOURce ] :RADio:DMODulation:ARB:MODulation[:TYPE] ?
```

This command sets the modulation type for the digital modulation personality.

***RST** P4DQPSK

Key Entry

ASK	BPSK	QPSK	UQPSk	IS95QPSK				
GREYQPSK	OQPSK	IS95OQPSK	P4DQPSK	PSK8	PSK16	D8PSK		
EDGE	MSK	FSK2	FSK4	FSK8	FSK16	C4FM		
HCPM	HDQPSK	QAM4	QAM16	QAM32	QAM64	QAM128		
QAM256	UIQ	UFSK						

Dmodulation Subsystem—Option 001/601 or 002/602 ([:SOURce]:RADio:DMODulation:ARB)

:MPOlarity:MARKer1|2|3|4

Supported E4438C with Option 401

[:SOURce]:RADio:DMODulation:ARB:MPOlarity:MARKer1|2|3|4 NEGative|POSitive

[:SOURce]:RADio:DMODulation:ARB:MPOlarity:MARKer1|2|3|4?

This command sets the polarity for the selected marker. For a positive marker polarity, the marker signal is high during the marker points. For a negative marker polarity, the marker signal is high during the period of no marker points.

***RST** POS

Key Entry	Marker 1 Polarity Neg	Marker 2 Polarity Neg	Marker 3 Polarity Neg
	Pos	Pos	Pos
	Marker 4 Polarity Neg Pos		

:REFerence:EXTernal:FREQuency

Supported E4438C with Option 001/601 or 002/602

[:SOURce]:RADio:DMODulation:ARB:REFerence:EXTernal:FREQuency <val>

[:SOURce]:RADio:DMODulation:ARB:REFerence:EXTernal:FREQuency?

This command conveys the expected reference frequency value of an externally applied reference the signal generator.

The variable <val> is expressed in units of Hertz (Hz–MHz).

***RST** +1.00000000E+007

Range 2.5E5–1E8

Key Entry **Reference Freq**

Remarks The value specified by this command is effective only when you are using an external ARB reference applied to the BASEBAND GEN REF IN rear panel connector.

To specify external as the ARB reference source type, refer to “:REFerence[:SOURce]” on page 281.

Dmodulation Subsystem—Option 001/601 or 002/602 ([:SOURCE]:RADio:DMODulation:ARB)**:REFeRence[:SOURce]**

Supported E4438C with Option 001/601 or 002/602

```
[:SOURCE]:RADio:DMODulation:ARB:REFeRence[:SOURCE] INTernal | EXTernal
[:SOURCE]:RADio:DMODulation:ARB:REFeRence[:SOURCE] ?
```

This command selects either an internal or external reference for the waveform clock.

***RST** INT

Key Entry ARB Reference Ext Int

Remarks If the EXTernal choice is selected, the external frequency value *must* be entered and the signal must be applied to the BASEBAND GEN REF IN rear panel connector.

Refer to “[:REFeRence:EXTernal:FREQUency](#)” on page 280 to enter the external reference frequency.

:RETRigger

Supported E4438C with Option 001/601 or 002/602

```
[:SOURCE]:RADio:DMODulation:ARB:RETRigger ON | OFF | IMMEDIATE
[:SOURCE]:RADio:DMODulation:ARB:RETRigger ?
```

This command enables or disables the ARB retriggering mode; the retrigger mode controls how the retriggering function performs while a waveform is playing.

ON (1) This choice specifies that if a trigger occurs while a waveform is playing, the waveform will retrigger at the end of the current waveform sequence and play once more.

OFF (0) This choice specifies that if a trigger occurs while a waveform is playing, the trigger will be ignored.

IMMEDIATE This choice specifies that if a trigger occurs while a waveform is playing, the waveform will reset and replay from the start immediately upon receiving a trigger.

***RST** ON

Key Entry On Off Immediate

Dmodulation Subsystem—Option 001/601 or 002/602 (:SOURce):RADio:DMODulation:ARB)

:SCLock:RATE

Supported E4438C with Option 001/601 or 002/602

[:SOURce] :RADio:DMODulation:ARB:SCLock:RATE <val>

[:SOURce] :RADio:DMODulation:ARB:SCLock:RATE?

This command sets the sample clock rate.

The variable <val> is expressed in units of Hertz (Hz – MHz)

***RST** +1.00000000E+008

Range 1–1E8

Key Entry ARB Sample Clock

Remarks The modulation format should be active before executing this command. If this command is executed before the modulation format is active, the entered value will be overridden by a calculated factory default value. Refer to “[:STATe]” on [page 293](#) to activate the modulation format.

:SETup

Supported E4438C with Option 001/601 or 002/602

[:SOURce] :RADio:DMODulation:ARB:SETup GSM | NADC | PDC | PHS | DECT | AC4Fm | ACQPsk

| AHCPm | AHDQpsk | CDPD | PWT | EDGE | TETra | MCARrier | "file name"

[:SOURce] :RADio:DMODulation:ARB:SETup?

This command selects the digital modulation format type or multicarrier, and turns multicarrier off or on (see the MCARrier choice description).

The *MCARrier* choice selects multicarrier and turns it on. Selecting any other setup such as GSM or CDPD turns multicarrier off. To select the multicarrier setup, see “[:SETup:MCARrier]” .

***RST** NADC

Key Entry GSM NADC PDC PHS DECT AC4Fm ACQPsk
 AHCPm AHDQpsk CDPD PWT EDGE TETra MCARrier
 "file name"

Remarks Refer to “File Name Variables” on [page 13](#) for information on the file name syntax.

Dmodulation Subsystem—Option 001/601 or 002/602 ([:SOURCE]:RADio:DMODulation:ARB)**:SETup:MCARrier**

Supported E4438C with Option 001/601 or 002/602

```
[ :SOURCE ] :RADio:DMODulation:ARB:SETup:MCARrier GSM|NADC|PDC|PHS|DECT|
AC4Fm|ACQPsk|CDPD|PWT|EDGE|TETRA, <num carriers>, <freq spacing> |
"<file name>"
[ :SOURCE ] :RADio:DMODulation:ARB:SETup:MCARrier?
```

This command builds a table with the specified number of carriers and frequency spacing or retrieves the setup stored in the specified user file.

The carrier type, number of carriers, and frequency spacing value are returned when a query is initiated. The output format is as follows:

```
<carrier type>, <num carriers>, <freq spacing>
```

If a specific file is loaded and then queried, only the file name is returned.

The variable <freq spacing> is expressed in units of Hertz (kHz–MHz).

```
*RST          Carrier: NADC    <num carriers>: 2
              <freq spacing>: +1.0000000000000E+06
```

```
Range          <num carriers>: 2–100
              <freq spacing>: 2 ÷ (<num carriers> – 1) × 80 MHz
```

```
Key Entry      GSM  NADC  PDC  PHS  DECT  APCO 25 w/C4FM  APCO w/CQPSK
               CDPD  PWT  EDGE  TETRA  # of Carriers  Freq Spacing
Custom Digital Mod State
```

Remarks Refer to [“File Name Variables” on page 13](#) for information on the file name syntax.

To store a multicarrier setup refer to [“:SETup:MCARrier:STORE” on page 284](#).

:SETup:MCARrier:PHASE

Supported E4438C with Option 001/601 or 002/602

```
[ :SOURCE ] :RADio:DMODulation:ARB:SETup:MCARrier:PHASE FIXed|RANDOM
[ :SOURCE ] :RADio:DMODulation:ARB:SETup:MCARrier:PHASE?
```

This command toggles the phase settings for multicarrier digital modulation.

FIXed This choice sets the phase of all carriers to 0.

RANDom This choice sets random phase values for all of the carriers.

Dmodulation Subsystem—Option 001/601 or 002/602 ([:SOURce]:RADio:DMODulation:ARB)

***RST** **FIX**
Key Entry **Carrier Phases Fixed Random**

:SETup:MCARrier:STORE

Supported E4438C with Option 001/601 or 002/602

`[:SOURce]:RADio:DMODulation:ARB:SETup:MCARrier:STORE "<file name>"`

This command stores the current multicarrier setup information.

The stored file contains information that includes the digital modulation format, number of carriers, frequency spacing, and power settings for the multicarrier setup.

Key Entry **Load/Store**

Remarks The setting enabled by this command is not affected by signal generator power-on, preset, or *RST.

Refer to “File Name Variables” on page 13 for information on the file name syntax.

:SETup:MCARrier:TABLE

Supported E4438C with Option 001/601 or 002/602

`[:SOURce]:RADio:DMODulation:ARB:SETup:MCARrier:TABLE INIT|APPend|
<carrier_num>,GSM|NADC|PDC|PHS|DECT|AC4Fm|ACQPsk|CDPD|PWT|EDGE|TETRa|
"<file name>",<freq_offset>,<power>
[:SOURce]:RADio:DMODulation:ARB:SETup:MCARrier:TABLE? <carrier_num>`

This command modifies the parameters of one of the available multicarrier digital modulation formats.

The variable <freq_offset> is expressed in units of Hertz (kHz–MHz).

The variable <power> is expressed in units of decibels (dB).

INIT This choice clears the current information and creates a new one-row table, allowing for further definition using additional parameters.

APPend This choice adds rows to an existing table.

<carrier_num> This variable specifies the number of the carriers in the multicarrier table that will be modified.

The value of the variable <carrier_num> must be specified prior to selecting the digital modulation format.

Dmodulation Subsystem—Option 001/601 or 002/602 ([:SOURCE]:RADio:DMODulation:ARB)

Carrier type, frequency offset, and power level are returned when a query is initiated. The output format is as follows:

<carrier type>, <freq_offset>, <power>

***RST** *carrier type*: NADC <freq_offset>: -5.00000000E+004

 <power>: +0.00000000E+000

Range <freq_offset>: -1E5 to 1E6 <power>: -40 to 0

Key Entry **Initialize Table Insert Row GSM NADC PDC PHS DECT**
APCO 25 w/C4FM APCO w/CQPSK CDPD PWT EDGE TETR
A

Custom Digital Mod State

Remarks Refer to “[File Name Variables](#)” on page 13 for information on the file name syntax.

To store a multicarrier setup refer to “[:SETup:MCARrier:STORE](#)” on page 284.

:SETup:MCARrier:TABLE:NCARriers

Supported E4438C with Option 001/601 or 002/602

[:SOURCE] :RADio:DMODulation:ARB:SETup:MCARrier:TABLE:NCARriers?

This query returns the number of carriers in the current multicarrier setup.

***RST** +2

Range 1–100

Key Entry # of Carriers

:SETup:STORE

Supported E4438C with Option 001/601 or 002/602

[:SOURCE] :RADio:DMODulation:ARB:SETup:STORE "<file name>"

This command stores the current custom digital modulation state.

The saved file contains information that includes the modulation type, filter and symbol rate for the custom modulation setup.

Key Entry **Store Custom Dig Mod State**

Remarks Refer to “[File Name Variables](#)” on page 13 for information on the file name syntax.

:SRATe

Supported E4438C with Option 001/601 or 002/602

[:SOURce]:RADio:DMODulation:ARB:SRATe <val>

[:SOURce]:RADio:DMODulation:ARB:SRATe?

This command sets the transmission symbol rate.

The variable <val> is expressed in units of symbols per second (sps–Mps) and the maximum range value is dependent upon the modulation type, and filter.

***RST** +2.43000000E+004

Range

<i>Modulation Type</i>	<i>Bits per Symbol</i>	<i>Internal Data</i>
BPSK	1	1sps–50 Mps
FSK2		
MSK		
C4FM	2	1sps–50 Mps
FSK4		
OQPSK		
OQPSK195		
P4QPPSK		
QAM4		
QPSK		
QPSKIS95		
QPSKISAT		
D8PSK		
EDGE		
FSK8		
PSK8		
FSK16	4	1sps–25 Mps
PSK16		
QAM16		
QAM32	5	1sps–20 Mps
QAM64	6	1sps–16.67 Mps
QAM256	8	1sps–12.50 Mps

Key Entry Symbol Rate

Remarks When user-defined filters are selected using the command in section “[:FILTER](#)” on [page 271](#), the upper bit rate will be restricted in line with the following symbol rate restriction:

- FIR filter length > 32 symbols: upper limit is 12.5 Mps

Dmodulation Subsystem—Option 001/601 or 002/602 ([:SOURCE]:RADio:DMODulation:ARB)

- FIR filter length > 16 symbols: upper limit is 25 Msps

When internal FIR filters are used, the limits of the above table always apply. For higher symbol rates, the FIR filter length will be truncated as follows:

- Above 12.5 Msps, the FIR length will be truncated to 32 symbols
- Above 25 Msps, the FIR length will be truncated to 16 symbols

This will impact the relative timing of the modulated data, as well as the actual filter response.

To change the modulation type, refer to “:MODulation[:TYPE]” on page 279.

:TRIGger:TYPE

Supported E4438C with Option 001/601 or 002/602

```
[:SOURCE]:RADio:DMODulation:ARB:TRIGger:TYPE CONTInuous|SINGle|GATE
[:SOURCE]:RADio:DMODulation:ARB:TRIGger:TYPE?
```

This command sets the trigger mode (type) that controls the waveform’s playback.

Triggers control the playback by telling the ESG when to play the modulating signal (waveform). Depending on the trigger settings for the ESG, the waveform playback can occur once, continuously, or the ESG may start and stop playing the waveform repeatedly (GATE mode).

A trigger signal comprises both positive and negative signal transitions (states), which are also called high and low periods. You can configure the ESG to trigger on either state of the trigger signal. It is common to have multiple triggers, also referred to as trigger occurrences or events, occur when the signal generator requires only a single trigger. In this situation, the ESG recognizes the first trigger and ignores the rest.

When you select a trigger mode, you may lose the signal (carrier plus modulating) from the RF output until you trigger the waveform. This is because the ESG sets the I and Q signals to zero volts prior to the first trigger event, which suppresses the carrier. After the first trigger event, the waveform’s final I and Q levels determine whether you will see the carrier signal or not (zero = no carrier, other values = carrier visible). At the end of most files, the final I and Q points are set to a value other than zero.

There are four parts to configuring the trigger:

- Choosing the trigger type, which controls the waveform’s transmission.
- Setting the waveform’s response to triggers:
 - CONTInuous, see “:TRIGger:TYPE:CONTInuous[:TYPE]” on page 288
 - SINGle, see “:RETRigger” on page 281
 - GATE, selecting the mode also sets the response

Dmodulation Subsystem—Option 001/601 or 002/602 (:SOURce):RADio:DMODulation:ARB)

- Selecting the trigger source (see “:TRIGger[:SOURce]” on page 290), which determines how the ESG receives its trigger signal, internally or externally. The GATE choice requires an external trigger.
- Setting the trigger polarity when using an external source:
 - CONTInuous and SINGle see “:TRIGger[:SOURce]:EXternal:SLOPe” on page 292
 - GATE, see “:TRIGger:TYPE:GATE:ACTive” on page 289

For more information on triggering, see the *E4428C/38C ESG Signal Generators User’s Guide*.

The following list describes the trigger type command choices:

CONTInuous	Upon triggering, the waveform repeats continuously.
SINGle	Upon triggering, the waveform segment or sequence plays once.
GATE	An external trigger signal repeatedly starts and stops the waveform’s playback (transmission). The time duration for playback depends on the duty period of the trigger signal and the gate polarity selection (see “:TRIGger:TYPE:GATE:ACTive” on page 289). The waveform plays during the inactive state and stops during the active polarity selection state. The active state can be set high or low. The gate mode works only with an external trigger source.

NOTE The ARB gating behavior described above is opposite to the gating behavior for real-time custom mode.

*RST	CONT
Key Entry	Continuous Single Gated

:TRIGger:TYPE:CONTInuous[:TYPE]

Supported E4438C with Option 001/601 or 002/602

```
[ :SOURce ] :RADio:DMODulation:ARB:TRIGger:TYPE:CONTInuous [ :TYPE ] FREE |
TRIGger | RESet
[ :SOURce ] :RADio:DMODulation:ARB:TRIGger:TYPE:CONTInuous [ :TYPE ] ?
```

This commands selects the waveform’s response to a trigger signal while using the continuous trigger mode.

For more information on triggering and to select the continuous trigger mode, see “:TRIGger:TYPE” on page 287.

Dmodulation Subsystem—Option 001/601 or 002/602 (:SOURce):RADio:DMODulation:ARB)

The following list describes the waveform's response to each of the command choices:

FREE	Turning the ARB format on immediately triggers the waveform. The waveform repeats until you turn the format off, select another trigger, or choose another waveform file.
TRIGger	The waveform waits for a trigger before play begins. When the waveform receives the trigger, it plays continuously until you turn the format off, select another trigger, or choose another waveform file.
RESet	The waveform waits for a trigger before play begins. When the waveform receives the trigger, it plays continuously. Subsequent triggers reset the waveform to the beginning. For a waveform sequence, this means to the beginning of the first segment in the sequence.
*RST	FREE
Key Entry	Free Run Trigger & Run Reset & Run

:TRIGger:TYPE:GATE:ACTive

Supported E4438C with Option 001/601 or 002/602

```
[ :SOURce ] :RADio:DMODulation:ARB:TRIGger:TYPE:GATE:ACTive LOW|HIGH
[ :SOURce ] :RADio:DMODulation:ARB:TRIGger:TYPE:GATE:ACTive?
```

This command selects the active state (gate polarity) of the gate while using the gating trigger mode.

The LOW and HIGH selections correspond to the low and high states of an external trigger signal. For example, when you select HIGH, the active state occurs during the high of the trigger signal. When the active state occurs, the ESG stops the waveform playback at the last played sample point, then restarts the playback at the next sample point when the inactive state occurs. For more information on triggering and to select gating as the trigger mode, see “:TRIGger:TYPE” on page 287.

The following list describes the ESG's gating behavior for the polarity selections:

LOW	The waveform playback stops when the trigger signal goes low (active state) and restarts when the trigger signal goes high (inactive state).
HIGH	The waveform playback stops when the trigger signal goes high (active state) and restarts when the trigger signal goes low (inactive state).
*RST	HIGH
Key Entry	Gate Active Low High

:TRIGger[:SOURce]

Supported E4438C with Option 001/601 or 002/602

[:SOURce] :RADio:DMODulation:ARB:TRIGger [:SOURce] KEY | EXT | BUS

[:SOURce] :RADio:DMODulation:ARB:TRIGger [:SOURce] ?

This command sets the trigger source.

For more information on triggering, see “:TRIGger:TYPE” on page 287. The following list describes the command choices:

KEY This choice enables manual triggering by pressing the front-panel **Trigger** hardkey.

EXT An externally applied signal triggers the waveform. This is the only choice that works with gating. The following conditions affect an external trigger:

- The input connector selected for the trigger signal. You have a choice between the rear-panel PATTERN TRIG IN connector or the PATT TRIG IN 2 pin on the rear-panel AUXILIARY I/O connector. To make the connector selection, see “:TRIGger[:SOURce]:EXTernal[:SOURce]” on page 292.

For more information on the connectors and on connecting the cables, see the *E4428C/38C ESG Signal Generators User’s Guide*.

- The trigger signal polarity:
 - gating mode, see “:TRIGger:TYPE:GATE:ACTive” on page 289
 - continuous and single modes, see “:TRIGger[:SOURce]:EXTernal:SLOPe” on page 292
- The time delay between when the ESG receives a trigger and when the waveform responds to the trigger. There are two parts to setting the delay:
 - setting the amount of delay, see “:TRIGger[:SOURce]:EXTernal:DELay” on page 291
 - turning the delay on, see “:TRIGger[:SOURce]:EXTernal:DELay:STATe” on page 291

BUS This choice enables triggering over the GPIB or LAN using the *TRG or GET commands or the AUXILIARY INTERFACE (RS-232) using the *TRG command.

***RST** EXT

Key Entry Trigger Key Ext Bus

Dmodulation Subsystem—Option 001/601 or 002/602 (:SOURce):RADio:DMODulation:ARB)**:TRIGger[:SOURce]:EXTernal:DELay**

Supported E4438C with Option 001/601 or 002/602

```
[ :SOURce ] :RADio:DMODulation:ARB:TRIGger [ :SOURce ] :EXTernal:DELay <val>
[ :SOURce ] :RADio:DMODulation:ARB:TRIGger [ :SOURce ] :EXTernal:DELay?
```

This command sets the amount of time to delay the ESG's response to an external trigger.

The delay is a path (time) delay between when the ESG receives the trigger and when it responds to the trigger. For example, configuring a trigger delay of two seconds, causes the ESG to wait two seconds after receipt of the trigger before the ESG plays the waveform.

The delay does not occur until you turn it on (see “:TRIGger[:SOURce]:EXTernal:DELay:STATe” on page 291). You can set the delay value either before or after turning it on.

For more information on configuring an external trigger source and to select external as the trigger source, see “:TRIGger[:SOURce]” on page 290.

The unit of measurement for the variable <val> is in seconds (nsec–sec).

***RST** +1.00000000E–003

Range 1E–8 to 4E1

Key Entry Ext Delay Time

:TRIGger[:SOURce]:EXTernal:DELay:STATe

Supported E4438C with Option 001/601 or 002/602

```
[ :SOURce ] :RADio:DMODulation:ARB:TRIGger [ :SOURce ] :EXTernal:DELay:
STATe ON|OFF|1|0
[ :SOURce ] :RADio:DMODulation:ARB:TRIGger [ :SOURce ] :EXTernal:DELay:STATe?
```

This command enables or disables the external trigger delay function.

For setting the delay time, see “:TRIGger[:SOURce]:EXTernal:DELay” on page 291, and for more information on configuring an external source, see “:TRIGger[:SOURce]” on page 290.

***RST** 0

Key Entry Ext Delay Off On

:TRIGger[:SOURce]:EXTernal:SLOPe

Supported E4438C with Option 001/601 or 002/602

```
[:SOURce]:RADio:DMODulation:ARB:TRIGger[:SOURce]:EXTernal:
SLOPe POSitive|NEGative
[:SOURce]:RADio:DMODulation:ARB:TRIGger[:SOURce]:EXTernal:SLOPe?
```

This command sets the polarity for an external trigger signal while using the continuous, single triggering mode. To set the polarity for gating, see “:TRIGger:TYPE:GATE:ACTive” on page 289.

The POSitive and NEGative selections correspond to the high (positive) and low (negative) states of the external trigger signal. For example, when you select POSitive, the waveform responds (plays) during the high state of the trigger signal. When the ESG receives multiple trigger occurrences when only one is required, the signal generator uses the first trigger and ignores the rest.

For more information on configuring an external trigger source and to select external as the trigger source, see “:TRIGger[:SOURce]” on page 290.

***RST** NEG

Key Entry Ext Polarity Neg Pos

:TRIGger[:SOURce]:EXTernal[:SOURce]

Supported E4438C with Option 001/601 or 002/602

```
[:SOURce]:RADio:DMODulation:ARB:TRIGger[:SOURce]:
EXTernal[:SOURce] EPT1|EPT2|EPTRIGGER1|EPTRIGGER2
[:SOURce]:RADio:DMODulation:ARB:TRIGger[:SOURce]:EXTernal[:SOURce]?
```

This command selects which PATTERN TRIG IN connection the ESG uses to accept an externally applied trigger signal when external is the trigger source selection.

For more information on configuring an external trigger source and to select external as the trigger source, see “:TRIGger[:SOURce]” on page 290. For more information on the rear-panel connectors, see the *E4428C/38C ESG Signal Generators User’s Guide*.

The following list describes the command choices:

- | | |
|------------|---|
| EPT1 | This choice is synonymous with EPTRIGGER1 and selects the PATTERN TRIG IN rear-panel connector. |
| EPT2 | This choice is synonymous with EPTRIGGER2 and selects the PATT TRIG IN 2 pin on the rear-panel AUXILIARY I/O connector. |
| EPTRIGGER1 | This choice is synonymous with EPT1 and selects the PATTERN TRIG IN rear-panel connector. |

Dmodulation Subsystem—Option 001/601 or 002/602 ([:SOURCE]:RADio:DMODulation:ARB)

EPTRIGGER2 This choice is synonymous with EPT2 and selects the PATT TRIG IN 2 pin on the rear-panel AUXILIARY I/O connector.

***RST** EPT1

Key Entry **Patt Trig In 1** **Patt Trig In 2**

[:STATe]

Supported E4438C with Option 001/601 or 002/602

[:SOURCE]:RADio:DMODulation:ARB[:STATe] ON|OFF|1|0

[:SOURCE]:RADio:DMODulation:ARB[:STATe] ?

This command enables or disables the digital modulation capability.

ON (1) This choice sets up the internal hardware to generate the currently selected digital modulation format signal selection.

OFF (0) This choice disables the digital modulation capability.

***RST** 0

Key Entry **Digital Modulation Off On**

Remarks When ON is selected, the I/Q state is activated and the I/Q source is set to internal.

Dual ARB Subsystem—Option 001/601 or 002/602 [:SOURce]:RADio:ARB)

:CLIPping

Supported E4438C with Option 001/601 or 002/602

```
[:SOURce]:RADio:ARB:CLIPping "<file name>", IJQ| IORQ, <val> [, <val>]
```

This command sets the clipping level of the selected waveform segment to a percentage of its highest peak.

The variable <val> is expressed in units of percent.

IJQ This choice clips the composite I/Q waveform.

IORQ This choice clips I and Q separately. When this choice is enabled, percentage values for both I and Q must be specified.

***RST** IJQ <val>: +100

Range <val>: 10–100 (0.1% resolution)

Key Entry **Clipping Type** |I+|Q| |I|,|Q|

Remarks A value of 100 percent equates to no clipping.

Refer to [“File Name Variables” on page 13](#) for information on the file name syntax.

:FILTer:ALPHa

Supported E4438C with Option 001/601 or 002/602

```
[:SOURce]:RADio:ARB:FILTer:ALPHa <val>
```

```
[:SOURce]:RADio:ARB:FILTer:ALPHa?
```

This command changes the Nyquist or Root Nyquist Real-Time Modulation filter alpha value.

The filter alpha value can be set to the minimum level (0), the maximum level (1), or in between by using fractional numeric values (0.001 to 0.999).

***RST** +3.50000000E-001

Range 0.000 to 1.000

Key Entry **Filter Alpha**

Dual ARB Subsystem—Option 001/601 or 002/602 (:SOURce):RADio:ARB)

Key Path **Mode > Dual ARB > Arb Setup > More 2 of 2 > Real-Time Modulation Filter > Filter Alpha**

Remarks To change the current filter type, refer to <\$elemtext..

:FILTer:BBT

Supported E4438C with Option 001/601 or 002/602

[:SOURce] :RADio:ARB:FILTer:BBT <val>

[:SOURce] :RADio:ARB:FILTer:BBT?

This command changes the bandwidth-multiplied-by-bit-time (BbT) Real-Time Modulation filter parameter.

The filter BbT value can be set to the minimum level (0.1), the maximum level (1), or in between by using fractional numeric values (0.100 to 0.999).

***RST** +5.00000000E-001

Range 0.100 to 1.000

Key Entry **Filter BbT**

Key Path **Mode > Dual ARB > Arb Setup > More 2 of 2 > Real-Time Modulation Filter > Filter BbT**

Remarks This command is effective only after choosing a Gaussian filter. It does not have an effect on other types of filters.

To change the current filter type, refer to “:FILTer:TYPE”.

:FILTer:CHANnel

Supported E4438C with Option 001/601 or 002/602

[:SOURce] :RADio:ARB:FILTer:CHANnel EVM|ACP

[:SOURce] :RADio:ARB:FILTer:CHANnel?

This command optimizes the Nyquist and Root Nyquist Real-Time Modulation filters to minimize error vector magnitude (EVM) or to minimize adjacent channel power (ACP).

EVM This choice provides the most ideal passband.

ACP This choice improves stopband rejection.

***RST** EVM

Key Entry **Optimize FIR For EVM ACP**

Key Path **Mode > Dual ARB > Arb Setup > More 2 of 2 > Real-Time Modulation Filter**

> **Optimize FIR For EVM ACP**

Remarks To change the current filter type, refer to “:FILTer:TYPE”.

:FILTer:TYPE

Supported E4438C with Option 001/601 or 002/602

```
[:SOURce]:RADio:ARB:FILTer:TYPE
RNYQuist|NYQuist|GAUSSian|RECTangle|IS95|IS95_EQ|IS95_MOD|IS95_MOD_EQ|EW
IDe|WCDMa|AC4Fm|EDGE|EHSR|"user FIR"
[:SOURce]:RADio:ARB:FILTer:TYPE?
```

This command specifies the Real-Time Modulation filter type.

RNYQuist	This choice selects a Root Nyquist (root raised cosine) filter. This filter is adjusted using Alpha.
NYQuist	This choice selects a Nyquist (raised cosine) filter. This filter is adjusted using Alpha.
GAUSSian	This choice selects a Gaussian filter which is adjusted using Bbt values.
RECTangle	This choice selects a one symbol wide rectangular filter.
IS95	This choice selects a filter that meets the criteria of the IS-95 standard.
IS95_EQ	This choice selects a filter which is a combination of the IS-95 filter (above) and the equalizer filter described in the IS-95 standard. This filter is only used for IS-95 baseband filtering.
IS95_MOD	This choice selects a filter that meets the criteria of the IS-95 error function (for improved adjacent channel performance) with lower passband rejection than the filter specified in the IS-95 standard.
IS95_MOD_EQ	This choice selects a filter which is a combination of the equalizer filter described in the IS-95 standard and a filter that meets the criteria of the IS-95 error function (for improved adjacent channel performance), with lower passband rejection.
EDGE	This choice selects a linearized Gaussian filter as defined in GSM 05.04.
EWIDe	This choice selects an EDGE spectrally wide pulse shape filter as per 3GPP TS 45.004.
EDGE EHSR	This choice selects an EDGE high symbol rate spectrally narrow pluse shape filter as per 3GPP TS 45.004.
WCDMa	This choice selects a W-CDMA filter which is the equivalent of a Root Nyquist filter with an alpha of 0.22 optimized for ACP.

Dual ARB Subsystem—Option 001/601 or 002/602 (:SOURce):RADio:ARB)

AC4Fm	This choice selects a predefined Association of Public Safety Communications Officials (APCO) specified compatible 4-level frequency modulation (C4FM) filter.		
"<user FIR>"	This variable is any FIR filter file that you have stored in memory. The variable needs no directory path indicating the location of the file, such as FIR: or /USER/FIR. The command assumes the FIR directory. For more information on file names, refer to “File Name Variables” on page 13.		
*RST	Root Nyquist		
Key Entry	Nyquist	IS-95	EDGE
	Gaussian	IS-95 Mod	WCDMA
	User FIR	IS-95 w/EQ	Rectangle
	Root Nyquist	IS-95 Mod w/EQ	EDGE Wide
		APCO 25 C4FM	EDGE EHSR
Key Path	Mode > Dual ARB > Arb Setup > More 2 of 2 > Real-Time Modulation Filter > Select > filter type		

:FILTer[:STATe]

Supported E4438C with Option 001/601 or 002/602

```
[ :SOURce ] :RADio:ARB:FILTer [ :STATe ] ON | {OFF} | 1 | 0
[ :SOURce ] :RADio:ARB:FILTer [ :STATe ] ?
```

This command enables or disables the **Real-Time Modulation Filter**. This filter is typically applied to an Arb waveform containing just the I/Q symbol decision points. The filter then defines the transitions between the symbol decision points. This means that the filter must have an oversample ratio of two or more. When this feature is active, the Sample Clock Rate is actually the Symbol Rate.

Default Off

Key Entry **Modulation Filter Off On**

Key Path **Mode > Dual Arb > Arb Set up > More 2 of 2 > Real-Time Modulation Filter (Off) > Modulation Filter Off On**

:GENerate:SINE

Supported E4438C with Option 001/601 or 002/602

```
[ :SOURce ] :RADio:ARB:GENerate:SINE ["<file_name>"] [ , <osr> ] , [ <scale> ] ,
[ I | Q | IQ ]
```

This command creates a sine wave waveform file and saves it in the signal generator's volatile waveform memory (WFM1).

"<file_name>" This variable names the file used to save the generated sine wave data.

Dual ARB Subsystem—Option 001/601 or 002/602 ([:SOURce]:RADio:ARB)

- <osr> This variable sets the oversample ratio, which must be an even number and ≥ 4 . The <osr> variable is expressed in samples. If the oversample ratio is < 60 (the minimum number of samples or I/Q points required for a waveform), multiple waveform periods are generated to create a waveform file with ≥ 60 samples. The number of periods created is $60 \div \text{<osr>}$ (quotient will round up to an integer value). A waveform with an oversample ratio ≥ 60 has one period.
- <scale> This variable sets the scale factor for the waveform. The scale factor is a real number from zero to one.
- I|Q|IQ Selects I, Q, or I and Q paths for the waveform data. Sinewave data is generated and applied to the I path if the I path is selected; Q data are set to zeros. Sine data is generated and applied to the Q path if the Q path is selected; I data are set to zeros. If the I and Q paths are selected, sinewave data are applied to the I and Q paths.

Example

```
:RAD:ARB:GEN:SINE "Sine_Wave",60,.5,IQ
```

The preceding example generates an I/Q sine wave and saves the data to a file named Sine_Wave. The oversampling ratio is 60, the scaling is set for 50%, and the data is applied to both the I and Q paths.

The signal generator's baseband option and available baseband memory determine the maximum number of samples for the waveform.

- Range** OSR Option 001/601: 4E0 – 8E6
OSR Option 002/602: 4E0 – 32E6
Scale: 0–1

:HEADer:CLEar

Supported E4438C with Option 001/601 or 002/602

```
[:SOURce]:RADio:ARB:HEADer:CLEar
```

This command clears the header information from the file header used by this modulation format.

Key Entry Clear Header

Remarks The **ARB Off On** softkey must be set to On for this command to function.

:HEADER:NOISe:RMS[:OVERride]

Supported E4438C with Option 001/601 or 002/602

```
[:SOURce]:RADio:ARB:HEADer:NOISe:RMS:OVERride <"filename">, <rms:0 -
```

Dual ARB Subsystem—Option 001/601 or 002/602 (:SOURce):RADio:ARB)

```
1.414213562373095>|UNSPecified
[:SOURce]:RADio:ARB:HEADer:NOISe:RMS:OVERride? <"filename">
```

This command sets the value of the waveform's I and Q RMS (root mean square) for noise.

The RMS is used strictly for calculating the relative power of the noise in the specified header. The RMS is specified in normalized linear units with $|+1|$ or $|-1|$ as full scale on I or Q, therefore the largest RMS that can be specified is the square root of 2 (1.414213562). If the value is unspecified, then the waveform file header's RMS is used.

This value is useful if you wish to have the noise be relative to only a portion of the waveform, such as a pilot channel, or be relative to only a single carrier that is mixed with other carriers.

For setting the header's RMS value, see [“:HEADer:RMS” on page 299](#).

<file_name> This variable names the waveform file to which the RMS value will be applied. The file name variable can designate a file in the WFM1, NVWFM, or SEQ directories. For information on the file name syntax, refer to [“File Name Variables” on page 13](#).

<value> This variable is the user-measured RMS noise value for the specified carrier.

UNSPecified Sets RMS as unspecified, which causes the general RMS value to be used for calculating the relative noise power.

Example

```
:RAD:ARB:HEADER:NOISe:RMS:OVER "WFM1:Sine_Wave",.835
```

The preceding example sets the file header RMS noise override value for a file type WFM1, named Sine_Wave, to .835.

```
:RAD:ARB:HEADER:NOISe:RMS:OVER "WFM1:Sine_Wave",UNSP
```

In the second example, the signal generator calculates the RMS, using the waveform file header's RMS value. For setting the header's RMS value, see [“:HEADer:RMS” on page 299](#).

The RMS value is expressed in volts.

Key Entry	Edit Noise RMS	Unspecified	Enter
	Override		

:HEADer:RMS

Supported E4438C with Option 001/601 or 002/602

```
[:SOURce]:RADio:ARB:HEADER:RMS "<file_name>",<val>|UNSPecified
[:SOURce]:RADio:ARB:HEADER:RMS? "<file_name>"
```

This command sets the file header RMS value for the selected waveform file. The ESG uses the RMS

Dual ARB Subsystem—Option 001/601 or 002/602 ([:SOURce]:RADio:ARB)

value with the dual ARB’s real-time noise function.

The signal generator reads the RMS value from the file header when real-time noise is enabled and the dual ARB turned on.

When the waveform file is saved from volatile waveform memory (WFM1) to non-volatile waveform memory (NVWFM), the RMS value, auto-calculated or user-defined, is also saved.

"<file_name>" This variable names the waveform file to which the RMS value will be applied. The file name variable can designate a file in the WFM1, NVWFM, or SEQ directories. For information on the file name syntax, refer to [“File Name Variables” on page 13](#).

<val> This variable is the user-measured RMS value for the specified waveform. The following figure shows the RMS calculation.

$$\sqrt{\sum_{n=1}^N (i_n^2 + q_n^2) \times \frac{1}{N}}$$

N = # of Samples

UNSPecified Using this variable in the command clears the RMS value and sets it to unspecified. An unspecified RMS value causes the signal generator to calculate the value when real-time noise is applied to the waveform during play back by the dual ARB player. The RMS calculation includes rise times and does not include consecutive zero level samples. DC offsets and noise are also included in the RMS measurement. Because the signal generator calculation uses so many parameters, you may achieve better results calculating your own RMS value.

Examples

```
[:SOURce]:RADio:ARB:HEADER:RMS "WFM1:Sine_Wave",.835
```

The first example shows a user-measured RMS value for the Sine_Wave waveform file in the waveform’s file header.

```
:RAD:ARB:HEADER:RMS "WFM1:Sine_Wave",UNSP
```

In the second example, the signal generator calculates the RMS value.

The RMS value is expressed in volts.

Range 0 – 1.414213562373095

:HEADer:SAVE

Supported E4438C with Option 001/601 or 002/602

[:SOURce] :RADio:ARB:HEADer:SAVE

This command saves the header information to the file header used by this modulation format.

Key Entry Save Setup To Header

Remarks The **ARB Off On** softkey must be set to On for this command to function.

:HCRest[:STATe]

Supported E4438C with Option 001/601 or 002/602

[:SOURce] :RADio:ARB:HCRest [:STATe] ON | OFF | 1 | 0

[:SOURce] :RADio:ARB:HCRest [:STATe] ?

This command enables or disables the operating state of the high crest mode.

ON(1) This choice turns high crest mode on for arbitrary I/Q waveforms with high crest factors (such as downloaded Signal Studio for 802.11 signals). High crest mode reduces the ALC vernier level by 7.5 dB, allowing the signal generator to process these signals with less distortion and improved EVM. For crest factors higher than 4 dB, I/Q drive levels should be reduced by 1 dB for each dB above that level. In high crest mode, the maximum output level is reduced and power level accuracy is degraded.

OFF(0) This choice disables the high crest mode.

***RST** 0

Key Entry High Crest Mode Off On

Remarks The high crest mode is automatically turned on by some Signal Studio applications. You can manually override this automatic selection at any time.

:IQ:EXTERNAL:FILTER

Supported E4438C with Option 001/601 or 002/602

```
[:SOURce]:RADio:ARB:IQ:EXTERNAL:FILTER 40e6|THROUGH
[:SOURce]:RADio:ARB:IQ:EXTERNAL:FILTER?
```

This command selects the filter or through path for I/Q signals routed to the rear panel I and Q outputs. The filter has not effect on the modulated RF signal. Selecting a filter using this command will automatically set “:IQ:EXTERNAL:FILTER:AUTO” on page 302 to OFF(0) mode.

40e6 This choice applies a 40 MHz baseband filter.

THROUGH This choice bypasses filtering.

***RST** THR

Key Entry 40.000 MHz Through

:IQ:EXTERNAL:FILTER:AUTO

Supported E4438C with Option 001/601 or 002/602

```
[:SOURce]:RADio:ARB:IQ:EXTERNAL:FILTER:AUTO ON|OFF|1|0
[:SOURce]:RADio:ARB:IQ:EXTERNAL:FILTER:AUTO?
```

This command enables or disables the automatic selection of the filters for I/Q signals routed to the rear panel I/Q outputs.

ON(1) This choice will automatically select a digital modulation filter optimized for the current signal generator settings.

OFF(0) This choice disables the auto feature which lets you select a digital modulation filter or through path. Refer to “:IQ:EXTERNAL:FILTER” on page 302 for selecting a filter or through path.

***RST** 1

Key Entry I/Q Output Filter Manual Auto

:IQ:MODULATION:ATTEN

Supported E4438C with Option 001/601 or 002/602

```
[:SOURce]:RADio:ARB:IQ:MODULATION:ATTEN <val>
[:SOURce]:RADio:ARB:IQ:MODULATION:ATTEN?
```

This command sets the attenuation level of the I/Q signals being modulated through the signal generator RF path.

Dual ARB Subsystem—Option 001/601 or 002/602 (:SOURce]:RADio:ARB)

The variable <val> is expressed in units of decibels (dB).

***RST** +2.00000000E+000
Range 0–40
Key Entry **Modulator Atten Manual Auto**

:IQ:MODulation:ATTen:AUTO

Supported E4438C with Option 001/601 or 002/602

```
[ :SOURce ] :RADio:ARB:IQ:MODulation:ATTen:AUTO ON|OFF|1|0
[ :SOURce ] :RADio:ARB:IQ:MODulation:ATTen:AUTO?
```

This command enables or disables the I/Q attenuation auto mode.

ON (1) This choice enables the attenuation auto mode which optimizes the modulator attenuation for the current conditions.

OFF (0) This choice holds the attenuator at its current setting or at a selected value. Refer to “[:IQ:MODulation:ATTen](#)” on page 302 for setting the attenuation value.

***RST** 1
Key Entry **Modulator Atten Manual Auto**

:IQ:MODulation:FILTer

Supported E4438C with Option 001/601 or 002/602

```
[ :SOURce ] :RADio:ARB:IQ:MODulation:FILTer 2.1e6|40e6|THROUGH
[ :SOURce ] :RADio:ARB:IQ:MODulation:FILTer?
```

This command enables you to select a filter or through path for I/Q signals modulated onto the RF carrier. This filter has no effect on the I/Q signal out the rear panel. Selecting a filter using this command will automatically set “[:IQ:MODulation:FILTer:AUTO](#)” on page 304 to OFF(0) mode.

2.1E6 This choice applies a 2.1 MHz baseband filter to the I/Q signals.

40E6 This choice applies a 40 MHz baseband filter to the I/Q signals.

THROUGH This choice bypasses filtering.

***RST** THR
Key Entry **2.100 MHz 40.000 MHz Through**

:IQ:MODulation:FILTer:AUTO

Supported E4438C with Option 001/601 or 002/602

```
[:SOURce]:RADio:ARB:IQ:MODulation:FILTer:AUTO ON|OFF|1|0
```

```
[:SOURce]:RADio:ARB:IQ:MODulation:FILTer:AUTO?
```

This command enables or disables the automatic selection of the filters for I/Q signals modulated onto the RF carrier.

ON(1) This choice will automatically select a digital modulation filter.

OFF(0) This choice disables the auto feature which lets you select a digital modulation filter or through path. Refer to “[:IQ:MODulation:FILTer](#)” on page 303 for selecting a filter or through path.

*RST 1

Key Entry I/Q Mod Filter Manual Auto

:MARKer:CLEar

Supported E4438C with Option 001/601 or 002/602

```
[:SOURce]:RADio:ARB:MARKer:CLEar "<file_name>",<marker>,<first_point>,<last_point>
```

This command clears a single marker point or a range of marker points on a waveform segment for the selected marker (1–4). The dual ARB player and all of the ARB modulation formats use this command.

"<file_name>" This variable specifies the name of the waveform file in volatile waveform memory (WFM1). Use the AUTOGEN_WAVEFORM file when clearing marker points for an active ARB format. The ESG automatically creates a file, using current settings, and names it AUTOGEN_WAVEFORM whenever an ARB format is turned on (except dual ARB); the same file name is used for all ARB formats. When all ARB formats are off, this file is still in waveform memory (WFM1) and available for use by the dual ARB player. For information on the file name syntax, see “[File Name Variables](#)” on page 13.

<marker> This variable selects the marker number; an integer value from one to four.

<first_point> This variable defines the first point in a range of points. The number must be greater than or equal to one, and less than or equal to the total number of waveform points.

If you enter a value for either the first marker point or the last marker point that would make the first marker point occur after the last, the last marker point automatically adjusts to match the first marker point.

Dual ARB Subsystem—Option 001/601 or 002/602 (:SOURce]:RADio:ARB)

<last_point> This variable defines the last point in a range of points. The number must be greater than or equal to the first point, and less than or equal to the total number of waveform points.

To clear a single marker point, use the same marker point for the first and last point variables. For more information on markers and ARB files, refer to the *E4428C/38C ESG Signal Generators User's Guide*.

Example

```
:RAD:ARB:MARK:CLE "Test_Data",1,1,300
```

The preceding example clears marker 1 from the first point through the 300th point in the Test_Data file.

Range

<marker>: 1–4

<first_Point>: 1–number of waveform points

<last_point>: <first_Point>–number of waveform points

Key Entry

Set Marker Off Range Of Points	Marker 1 2 3	First Mkr Point	Last Mkr Point
	4		

:MARKer:CLEar:ALL**Supported**

E4438C with Option 001/601 or 002/602

```
[ :SOURce ] :RADio:ARB:MARKer:CLEar:ALL "<file_name>",<marker>
```

This command clears all marker points on a waveform segment for the selected marker (1–4). The dual ARB player and all of the ARB formats use this command. With all marker points cleared, the event output signal level is set low.

"<file_name>"

This variable specifies the name of the waveform file in volatile waveform memory (WFM1). Use the AUTOGEN_WAVEFORM file when clearing all marker points for the currently active ARB format. The ESG automatically creates a file, using current settings, and names it AUTOGEN_WAVEFORM whenever an ARB format is turned on (except dual ARB); the same file name is used for all ARB formats. When all ARB formats are off, this file is still in waveform memory (WFM1) and available for use by the dual ARB player. For information on the file name syntax, see [“File Name Variables” on page 13](#).

<marker>

This variable selects the marker number; an integer value from one to four.

Example

```
:RAD:ARB:MARK:CLE:ALL "Test_Data",1
```

The preceding example clears marker 1 from the all waveform points in the Test_Data file.

Range

1–4

Key Entry	Marker 1 2 3	Set Marker Off All
	4	Points

:MARKer:ROtate

Supported E4438C with Option 001/601 or 002/602

```
[:SOURce]:RADio:ARB:MARKer:ROtate "<file_name>",<rotate_count>
```

This command shifts the marker points for all markers in a waveform segment earlier or later by the value of the <rotate_count> variable. The dual ARB player and all of the ARB formats use this command.

You can use a positive or negative value. When a marker point is close to the end of the waveform and the <rotate_count> value is greater than the number of remaining marker points, but less than the total number of marker points, the marker points that would move beyond the end of the waveform wrap to the beginning of the waveform. For example, if a marker point resides at sample point 195 out of 200, and the <rotate_count> value is twenty-five, the marker point wraps to the beginning of the waveform and continues out to the twentieth waveform point.

To set the marker points in a waveform, refer to “:MARKer:[SET]” on page 306.

"<file_name>" This variable specifies the name of the waveform file in volatile waveform memory (WFM1). Use the AUTOGEN_WAVEFORM file when rotating marker points for the currently active ARB format and then save the file using a different file name. The ESG automatically creates a file, using current settings, and names it AUTOGEN_WAVEFORM whenever an ARB format is turned on (except dual ARB); the same file name is used for all ARB formats. When all ARB formats are off, this file is still in waveform memory (WFM1) and available for use by the dual ARB player. For information on the file name syntax, see “File Name Variables” on page 13.

Example

```
:RAD:ARB:MARK:ROT "Test_Data",100
```

The preceding example shifts all markers set in the Test_Data file 100 points later. If the first set point in the file is at 50, then after sending this command, the first set point will be 150 (assuming the Test_Data file has at least 150 points) and no later set points wrapped around to the beginning of the file.

Range $-(n - 1)$ to $(n - 1)$
 n = number of points in the waveform

:MARKer:[SET]

Supported E4438C with Option 001/601 or 002/602

Dual ARB Subsystem—Option 001/601 or 002/602 (:SOURce]:RADio:ARB)

```
[ :SOURce ] :RADio:ARB:MARKer: [SET] "<file_name>", <marker>, <first_point>,
<last_point>, <skip_count>
```

This command sets a single marker point or a range of marker points on a waveform segment for the selected marker (1–4). The dual ARB player and all of the ARB formats use this command.

The ESG provides four independent markers. Each marker routes an output signal to the rear-panel event connector number (BNC—EVENT 1 and EVENT 2 or AUXILIARY I/O—EVENT 3 and EVENT 4) that corresponds to the marker number. A marker consists of marker points placed at defined sample points in a waveform segment. This means that a marker point cannot be less than one or greater than the last sample point in the waveform. Marker points are cumulative, so multiple command executions with different range values, without first clearing the existing points, places additional marker points on the waveform. Because of this cumulative behavior, it is a good practice to clear existing marker points prior to setting new points. This will eliminate unexpected marker pulses. Refer to “:MARKer:CLEar” on page 304 and “:MARKer:CLEar:ALL” on page 305 for information on clearing marker points.

For waveforms generated on the signal generator (baseband generator), the ESG automatically places a marker point at the first waveform sample for markers one and two.

NOTE You can set markers for either positive or negative polarity. The following discussions for this command assume positive marker polarity. When using negative marker polarity, the marker pulses occur during the periods of no marker points.

There are three ways to place marker points using this command:

- consecutive marker points over a range that collectively create a single marker pulse that spans the range
- equally spaced marker points over a range, so that a marker pulse occurs at each sample point that coincides with a marker point (Using this method, you can configure a clock signal by setting the <skip_count> variable to one.)
- a single marker point placed at a specific sample point in the waveform, which outputs a single pulse relative to the marker point location (To configure a single marker point, set the first and last points to the same number.)

For more information on markers, refer to the *E4428C/38C ESG Signal Generators User’s Guide*.

The following list describes the command variables:

"<file_name>" This variable specifies the name of the waveform file in volatile waveform memory (WFM1). Use the AUTOGEN_WAVEFORM file when setting marker points for the currently active ARB format and then save the file using a different file name. The ESG automatically creates a file, using current settings, and names it AUTOGEN_WAVEFORM whenever an ARB format is turned on (except dual

Dual ARB Subsystem—Option 001/601 or 002/602 ([:SOURce]:RADio:ARB)

ARB); the same file name is used for all ARB formats. When all ARB formats are off, this file is still in waveform memory (WFM1) and available for use by the dual ARB player. For information on the file name syntax, see “File Name Variables” on page 13.

- <marker> This variable selects the marker number; an integer value from one to four.
- <first_point> This variable defines the first point in the range over which the marker is placed. This number must be greater than or equal to one, and less than or equal to the total number of waveform points.

If you enter a value for either the first marker point or the last marker point that would make the first marker point occur after the last, the last marker point is automatically adjusted to match the first marker point.
- <last_point> This variable defines the last point in the range over which the marker will be placed. This value must be greater than or equal to the first point, and less than or equal to the total number of waveform points.
- <skip_count> This variable defines the marker point pattern across the range. A zero value means the marker points occur consecutively across the range. A value greater than zero creates a repeating marker point pattern across the range, where the gap between the marker points is equal to the <skip_count> value. The gaps begin after the first marker point. Each marker point in the pattern, which is only one point wide, produces a marker pulse.

Example

```
:RAD:ARB:MARK "Test_Data",1,40,100,2
```

The preceding example sets marker 1 on the first point, 40, the last point, 100, and every third point (skip 2) between 40 and 100 (assuming the Test_Data file has at least 100 points).

- Range** <marker>: 1–4
- <first_Point>: 1–number of waveform points
- <last_point>: <first_Point>–number of waveform points
- <skip_count>: 0–number of points in the range

Key Entry	Set Marker on Range Of	Marker 1 2 3	First Mkr	Last Mkr
	Points	4	Point	Point
	# Skipped	Apply to		
	Points	Waveform		

:MDEStination:AAMPlitude

Supported E4438C with Option 001/601 or 002/602

```
[ :SOURce ] :RADio:ARB:MDEStination:AAMPlitude NONE | M1 | M2 | M3 | M4
```

```
[ :SOURce ] :RADio:ARB:MDEStination:AAMPlitude?
```

This command routes the selected marker to the Alternate Amplitude function. The NONE parameter clears the marker for the Alternate Amplitude function.

***RST** NONE

Key Entry None Marker 1 Marker 2 Marker 3 Marker 4

:MDEStination:ALCHold

Supported E4438C with Option 001/601 or 002/602

CAUTION Incorrect automatic level control (ALC) sampling can create a sudden unlevelled condition that may create a spike in the RF output potentially damaging a DUT or connected instrument. Ensure that you set markers to let the ALC sample over an amplitude that accounts for the high power levels within the signal.

```
[ :SOURce ] :RADio:ARB:MDEStination:ALCHold NONE | M1 | M2 | M3 | M4
```

```
[ :SOURce ] :RADio:ARB:MDEStination:ALCHold?
```

This command enables or disables the marker ALC hold function for the selected marker. For setting markers, see “:MARKer:[SET]” on page 306.

Use the ALC hold function when you have a waveform signal that incorporates idle periods, or when the increased dynamic range encountered with RF blanking is not desired. The ALC leveling circuitry responds to the marker signal during the marker pulse (marker signal high), averaging the modulated signal level during this period.

The ALC hold function operates during the low periods of the marker signal. The marker polarity determines when the marker signal is high. For a positive polarity, this is during the marker points. For a negative polarity, this is when there are no marker points. For setting a marker’s polarity, see “:MPOlarity:MARKer1|2|3|4” on page 312.

NOTE Do not use the ALC hold for more than 100 ms, because it can affect the waveform’s output amplitude.

The marker signal has a minimum of a two-sample delay in its response relative to the waveform signal response. To compensate for the marker signal delay, offset marker points from the waveform

Dual ARB Subsystem—Option 001/601 or 002/602 ([:SOURce]:RADio:ARB)

sample point at which you want the ALC sampling to begin.

The ALC hold setting is part of the file header information, so saving the setting to the file header saves the current marker routing for the waveform file.

NOTE A waveform file that has unspecified settings in the file header uses the previous waveform’s routing settings.

For more information on the marker ALC hold function, see the *E4428C/38C ESG Signal Generators User’s Guide*. For setting the marker points, see “:MARKer:[SET]” on page 306.

- NONE This terminates the marker ALC hold function.
- M1–M4 These are the marker choices. The ALC hold feature uses only one marker at a time.
- *RST NONE

Example

```
:RAD:ARB:MDES:ALCH M1
```

The preceding example routes marker 1 to the ALC Hold function.

Key Entry	None	Marker 1	Marker 2	Marker 3	Marker 4
Remarks	N/A				

:MDEStination:PULSe

Supported E4438C with Option 001/601 or 002/602

CAUTION The pulse function incorporates ALC hold. Incorrect automatic level control (ALC) sampling can create a sudden unlevelled condition that may create a spike in the RF output potentially damaging a DUT or connected instrument. Ensure that you set markers to let the ALC sample over an amplitude that accounts for the high power levels within the signal.

```
[[:SOURce]:RADio:ARB:MDEStination:PULSe NONE | M1 | M2 | M3 | M4  
[:SOURce]:RADio:ARB:MDEStination:PULSe?
```

This command enables or disables the marker pulse/RF blanking function for the selected marker.

This function automatically uses the ALC hold function, so there is no need to select both the ALC hold and pulse/RF blanking functions for the same marker.

NOTE Do not use ALC hold for more than 100 ms, because it can affect the waveform’s output amplitude.

The signal generator blanks the RF output when the marker signal goes low. The marker polarity determines when the marker signal is low. For a positive polarity, this is during the marker points. For a negative polarity, this is when there are no marker points. For setting a marker’s polarity, see “:MPOLarity:MARKer1|2|3|4” on page 312.

NOTE Set marker points prior to using this function. Enabling this function without setting marker points may create a continuous low or high marker signal, depending on the marker polarity. This causes either no RF output or a continuous RF output. See “:MARKer:[SET]” on page 306 for setting the marker points.

The marker signal has a minimum of a two-sample delay in its response relative to the waveform signal response. To compensate for the marker signal delay, offset marker points from the waveform sample point at which you want the RF blanking to begin. The RF blanking setting is part of the file header information, so saving the setting to the file header saves the current marker routing for the waveform file.

NOTE A waveform file that has unspecified settings in the file header uses the previous waveform’s routing settings. This could create the situation where there is no RF output signal, because the previous waveform used RF blanking.

For more information on the marker RF blanking function, see the *E4428C/38C ESG Signal Generators User’s Guide*.

NONE This terminates the marker RF blanking/pulse function.

M1–M4 These are the marker choices. The RF blanking/pulse feature uses only one marker at a time.

Example

```
:RAD:ARB:MDES:PULS M2
```

The preceding example routes marker 2 to Pulse/RF Blanking.

```
*RST NONE
```

```
Key Entry None Marker 1 Marker 2 Marker 3 Marker 4
```

:MPOlarity:MARKer1|2|3|4

Supported E4438C with Option 001/601 or 002/602

```
[ :SOURce ] :RADio:ARB:MPOlarity:MARKer1 | 2 | 3 | 4 NEGative | POSitive
[ :SOURce ] :RADio:ARB:MPOlarity:MARKer1 | 2 | 3 | 4 ?
```

This command sets the polarity for the selected marker. For a positive marker polarity, the marker signal is high during the marker points. For a negative marker polarity, the marker signal is high during the period of no marker points.

Example

```
:RAD:ARB:MPOL:MARK3 NEG
```

The preceding example sets the polarity for marker 3 to negative.

***RST** POS

Key Entry	Marker 1 Polarity	Marker 2 Polarity	Marker 3 Polarity
	Neg	Neg	Neg
	Pos	Pos	Pos
	Marker 4 Polarity Neg Pos		

:NOISe:BFACTOR

Supported E4438C with Option 403

```
[ :SOURce ] :RADio:ARB:NOISe:BFACTOR 1 | 2
[ :SOURce ] :RADio:ARB:NOISe:BFACTOR ?
```

This command sets the flat noise bandwidth for the real-time noise applied to the waveform.

- 1 This sets the noise bandwidth to at least 0.8 times the sample rate.
- 2 This sets the noise bandwidth to at least 1.6 times the sample rate, with a maximum bandwidth of 80 MHz.

NOTE For the bandwidth factor of 2, 50 MHz is the maximum sample rate. If 2 is the current selection, you cannot set the sample rate above 50 MHz, and if the sample rate is above 50 MHz, you cannot select 2. See “:SCLock:RATE” on page 317 for setting the sample rate.

The flat noise bandwidth increases with any oversampling by a factor equal to the oversampling amount.

Example

```
:RAD:ARB:NOIS:BFAC 2
```

The preceding example sets the bandwidth factor to 2 and increases the flat noise bandwidth by at least 1.6 times the ARB sample clock rate.

```
*RST +1
```

Key Entry **Noise Bandwidth Factor**

:NOISe:CBWidth

Supported E4438C with Option 403

```
[ :SOURce ] :RADio:ARB:NOISe:CBWidth <val><unit>
[ :SOURce ] :RADio:ARB:NOISe:CBWidth?
```

This command selects the carrier bandwidth over which the additive white gaussian noise (AWGN) is applied. The noise power will be integrated over the selected bandwidth for the purposes of calculating carrier to noise ratio (C/N). The carrier bandwidth is limited to the ARB sample rate, but cannot exceed 80 MHz. For more information, refer to “:NOISe[:STATe]” and “:NOISe:BFACtor”.

```
*RST +1.00000000E+000
```

Range 1HZ–80 MHZ

Key Entry **Carrier Bandwidth**

:NOISe:CN

Supported E4438C with Option 403

```
[ :SOURce ] :RADio:ARB:NOISe:CN <val><unit>
[ :SOURce ] :RADio:ARB:NOISe:CN?
```

This command sets the carrier to noise ratio (C/N) in dB. The carrier power is defined as the total modulated signal power without noise power added. The noise power is applied over the specified bandwidth of the carrier signal. For more information, refer to “:NOISe:CBWidth” on page 313.

Example

```
:RAD:ARB:NOIS:CN 50DB
```

The preceding example sets the carrier to noise ratio to 50 dB.

```
*RST +0.00000000E+000
```

Range –100 to 100DB

Key Entry **Carrier to Noise Ratio**

:NOISe[:STATe]**Supported** E4438C with Option 403

```
[:SOURce]:RADio:ARB:NOISe[:STATe] ON|OFF|1|0
[:SOURce]:RADio:ARB:NOISe[:STATe] ?
```

This command enables or disables adding real-time additive white gaussian noise (AWGN) to the carrier modulated by the waveform being played by the dual ARB waveform player. The noise bandwidth will be at least 0.8 times the sample rate, or 1.6 times the sample rate depending on the bandwidth factor. For information on the bandwidth factor, refer to “:NOISe:BFACtor”.

When the bandwidth factor is 2 and the sample rate is greater than 50 megasamples per/second, noise cannot be enabled. Maximum bandwidth cannot exceed 80 MHz. Any oversampling in the waveform increases the noise bandwidth by a factor equal to the oversampling.

Example

```
:RAD:ARB:NOIS ON
```

The preceding example applies real-time AWGN to the carrier.

```
*RST 0
```

Key Entry Real-time Noise Off On**:REFerence:EXTernal:FREQuency****Supported** E4438C with Option 001/601 or 002/602

```
[:SOURce]:RADio:ARB:REFerence:EXTernal:FREQuency <value>
[:SOURce]:RADio:ARB:REFerence:EXTernal:FREQuency ?
```

This command enters the frequency of the applied external reference.

The variable <val> is expressed in units of Hertz (Hz–MHz).

```
*RST +1.00000000E+007
```

Range 2.5E5–1E8**Key Entry** Reference Freq

Remarks The value specified by this command is effective only when you are using an external ARB reference applied to the BASEBAND GEN REF IN rear panel connector.

To specify external as the ARB reference source type, refer to “:REFerence[:SOURce]” on page 315.

:REFeRence[:SOURce]

Supported E4438C with Option 001/601 or 002/602

```
[ :SOURce ] :RADio:ARB:REFeRence [ :SOURce ] INTernal | EXTeRnal
[ :SOURce ] :RADio:ARB:REFeRence [ :SOURce ] ?
```

This command selects either an internal or external reference for the waveform clock.

***RST** INT

Key Entry ARB Reference Ext Int

Remarks If the EXTeRnal choice is selected, the external frequency value *must* be entered and the signal must be applied to the BASEBAND GEN REF IN rear panel connector.

Refer to “:REFeRence:EXTeRnal:FREQUency” on page 314 to enter the external reference frequency.

:RETRigger

Supported E4438C with Option 001/601 or 002/602

```
[ :SOURce ] :RADio:ARB:RETRigger ON | OFF | 1 | 0 | IMMEDIATE
[ :SOURce ] :RADio:ARB:RETRigger ?
```

This command enables or disables the ARB retriggering mode; the retrigger mode controls how the retriggering function performs while a waveform is playing.

ON (1) This choice specifies that if a trigger occurs while a waveform is playing, the waveform will retrigger at the end of the current waveform sequence and play once more.

OFF (0) This choice specifies that if a trigger occurs while a waveform is playing, the trigger will be ignored.

IMMEDIATE This choice specifies that if a trigger occurs while a waveform is playing, the waveform will reset and replay from the start immediately upon receiving a trigger.

***RST** ON

Key Entry On Off Immediate

:RSCAling

Supported E4438C with Option 001/601 or 002/602

```
[:SOURce]:RADio:ARB:RSCAling <val>
```

```
[:SOURce]:RADio:ARB:RSCAling?
```

This command adjusts the scaling value that is applied to a waveform while it is playing. The variable <val> is expressed as a percentage. Runtime scaling does not alter the waveform data file. For more information about runtime scaling, refer to the *E4428C/38C ESG Signal Generators User's Guide*.

Example

```
:RAD:ARB:RSC 50
```

The preceding example applies a 50% scaling factor to the selected waveform.

***RST** +7.00000000E+001

Range 1–100

Key Entry **Waveform Runtime Scaling**

Remarks Runtime scaling does not alter the waveform data file.

:SCAling

Supported E84438C with Option 001/601 or 002/602

```
[:SOURce]:RADio:ARB:SCAling "<file_name>", <val>
```

This command scales the designated "<file_name>" waveform file while it is being played by the dual ARB player. The variable <val> is expressed as a percentage, 1–100%. For information on file name syntax, see [“File Name Variables” on page 13](#).

Scaling is additive and permanent. You cannot scale up. If you scale a waveform file by 60% and then scale it again to 80% you will scale down the 60% waveform file. For more information about waveform file scaling, refer to the *E4428C/38C ESG Signal Generators User's Guide*.

Example

```
:RAD:ARB:SCAL "Test_Data", 50
```

The preceding example applies a 50% scaling factor to the Test_Data waveform file.

Range 1–100

Remarks Refer to [“File Name Variables” on page 13](#) for information on the file name syntax.

Dual ARB Subsystem—Option 001/601 or 002/602 (:SOURce):RADio:ARB)

Key Entry	Scaling	Scale Waveform Data
Remarks	Refer to “File Name Variables” on page 13 for information on the file name syntax.	

:SCLock:RATE

Supported E4438C with Option 001/601 or 002/602

```
[ :SOURce ] :RADio:ARB:SClock:RATE <val>
[ :SOURce ] :RADio:ARB:SClock:RATE?
```

This command sets the sample clock rate for the dual ARB format.

The variable <val> is expressed in units of hertz.

***RST** +1.00000000E+008

Range 1–1E8

Key Entry ARB Sample Clock

:SEquence

Supported All with Option 001/601 or 002/602

```
[ :SOURce ] :RADio:ARB:SEquence
"<file_name>", "<waveform1>", <reps>, NONE | M1 | M2 | M3 | M4 | M1M2 | M1M3 | M1M4 | M2M3 |
M2M4 | M3M4 | M1M2M3 | M1M2M4 | M1M3M4 | M2M3M4 | ALL, { "<waveform2>", <reps>, NONE | M1 |
M2 | M3 | M4 | M1M2 | M1M3 | M1M4 | M2M3 | M2M4 | M3M4 | M1M2M3 | M1M2M4 | M1M3M4 | M2M3M4 | ALL }
[ :SOURce ] :RADio:ARB:SEquence? "<file_name>"
```

This command creates a waveform sequence. A waveform sequence is made up of segments and other sequences. Any number of segments, up to a segment count limit of 32768, can be used to create a sequence. The count limit is determined by the number of segments in the waveform sequence. Repeated segments are included in the count limit.

For example, using the figure below, suppose a waveform is created using two sequences: Sequence_A and Sequence_B. Sequence_A consists of Sequence_B and Segment_Q with Sequence_B repeated four times. The total segment count for this waveform sequence would be eleven.

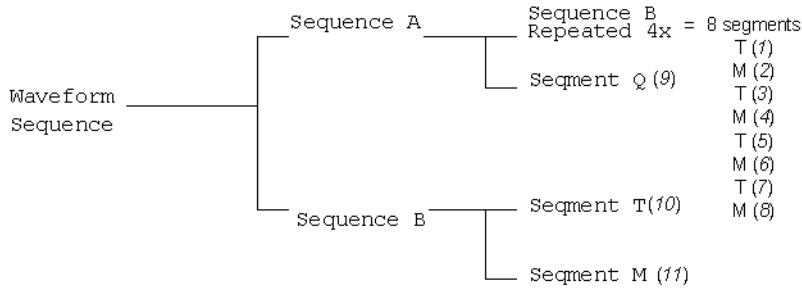

The query returns the contents and segment settings of the waveform sequence file

The segments and sequences play in the same order as placed into the waveform sequence by the command. Once you create the file, you cannot edit the segment settings or add further waveform segments unless you use the signal generator’s front panel. Using the same waveform sequence name overwrites the existing file with that name. To use a segment’s marker settings, you must enable the segment’s markers within the segment or within the waveform sequence. A sequence is stored in the catalog of SEQ files USER/SEQ or SEQ: directory.

When you create a waveform sequence, the ESG also creates a file header for the sequence. This file header takes priority over segment or nested sequence file headers. Refer to the *E4428C/38C ESG Signal Generators User’s Guide* for more information on file headers. To save the file header, see “:HEADer:SAVE” on page 301.

- "<file_name>" This variable names the waveform *sequence* file. For information on the file name syntax, see “File Name Variables” on page 13.
- "<waveform1>" This variable specifies the name of an existing waveform *segment* or sequence file. A waveform segment or the waveform segments in a specified sequence must reside in volatile memory, WFM1, before it can be played by the dual ARB player. For information on the file name syntax, see “File Name Variables” on page 13, and for more information on waveform segments, see the *E4428C/38C ESG Signal Generators User’s Guide*.
- "<waveform2>" This variable specifies the name of a second existing waveform *segment* or sequence file. The same conditions required for waveform1 apply for this segment or sequence. Additional segments and other sequences can be inserted into the file.
- <reps> This variable sets the number of times a segment or sequence plays (repeats) before the next segment or sequence plays.

Dual ARB Subsystem—Option 001/601 or 002/602 (:SOURce):RADio:ARB)

- NONE This choice disables all four markers for the waveform. Disabling markers means that the waveform sequence ignores the segment’s or sequence’s marker settings.
- M1, M2, M3, M4 These choices, either individually or a combination of them, enable the markers for the waveform segment or sequence. Markers not specified are ignored for that segment or sequence.
- ALL This choice enables all four markers in the waveform segment or sequence.

Example

```
:RAD:ARB:SEQ "SEQ:Test_Data","WFM1:ramp_test_wfm",25,M1M4,
"WFM1:sine_test_wfm",100,ALL
```

NOTE A carriage return or line feed is never included in a SCPI command. The example above contains a carriage return so that the text will fit on the page.

The preceding example creates a waveform sequence file named Test_Data. This file consists of the factory-supplied waveform segments, ramp_test_wfm and sine_test_wfm. The waveform is stored in the signal generator’s SEQ: directory.

- The first segment, ramp_test_wfm, has 25 repetitions with markers 1 and 4 enabled.
- The second segment, sine_test_wfm, has 100 repetitions with all four markers enabled.

Range	<reps>: 1–65535			
Key Entry	Build New Waveform Sequence	Name and Store	Insert Waveform	
	Edit	Toggle Marker	Toggle Marker	Toggle Marker
	Repetitions	1	2	3
	Toggle Marker	4		

:TRIGger:TYPE

Supported E4438C with Option 001/601 or 002/602

```
[ :SOURce ] :RADio:ARB:TRIGger:TYPE CONTinuous | SINGle | GATE | SADVance
[ :SOURce ] :RADio:ARB:TRIGger:TYPE?
```

This command sets the trigger mode (type) that controls the waveform’s playback.

Triggers control the playback by telling the ESG when to play the modulating signal (waveform). Depending on the trigger settings for the ESG, the waveform playback can occur once, continuously, or the ESG may start and stop playing the waveform repeatedly (GATE mode).

A trigger signal comprises both positive and negative signal transitions (states), which are also called high and low periods. You can configure the ESG to trigger on either state of the trigger signal. It is common to have multiple triggers, also referred to as trigger occurrences or events, occur when the signal generator requires only a single trigger. In this situation, the ESG recognizes the first trigger and ignores the rest.

When you select a trigger mode, you may lose the signal (carrier plus modulating) from the RF output until you trigger the waveform. This is because the ESG sets the I and Q signals to zero volts prior to the first trigger event, which suppresses the carrier. After the first trigger event, the waveform's final I and Q levels determine whether you will see the carrier signal or not (zero = no carrier, other values = carrier visible). At the end of most files, the final I and Q points are set to a value other than zero.

There are four parts to configuring the trigger:

- Choosing the trigger type, which controls the waveform's transmission.
- Setting the waveform's response to triggers:
 - CONTInuous, see [“:TRIGger:TYPE:CONTInuous\[:TYPE\]”](#) on page 321
 - SINGle, see [“:RETRigger”](#) on page 315
 - GATE, selecting the mode also sets the response
- Selecting the trigger source (see [“:TRIGger\[:SOURce\]”](#) on page 324), which determines how the ESG receives its trigger signal, internally or externally. The GATE choice requires an external trigger.
- Setting the trigger polarity when using an external source:
 - CONTInuous and SINGle see [“:TRIGger\[:SOURce\]:EXTernal:SLOPe”](#) on page 326
 - GATE, see [“:TRIGger:TYPE:GATE:ACTive”](#) on page 321

For more information on triggering, see the *E4428C/38C ESG Signal Generators User's Guide*.

The following list describes the trigger type command choices:

CONTInuous	Upon triggering, the waveform repeats continuously.
SINGle	Upon triggering, the waveform segment or sequence plays once.
GATE	An external trigger signal repeatedly starts and stops the waveform's playback (transmission). The time duration for playback depends on the duty period of the trigger signal and the gate polarity selection (see “:TRIGger:TYPE:GATE:ACTive” on page 321). The waveform plays during the inactive state and stops during the active polarity selection state. The active state can be set high or low. The gate mode works only with an external trigger source.

NOTE The ARB gating behavior described above is opposite to the gating behavior for

real-time custom mode.

*RST	CONT			
Key Entry	Continuous	Single	Gate	Segment Advance

:TRIGger:TYPE:CONTInuous[:TYPE]

Supported E4438C with Option 001/601 or 002/602

```
[ :SOURce ] :RADio:ARB:TRIGger:TYPE:CONTInuous [ :TYPE ] FREE | TRIGger | RESet
[ :SOURce ] :RADio:ARB:TRIGger:TYPE:CONTInuous [ :TYPE ] ?
```

This command selects the waveform's response to a trigger signal while using the continuous trigger mode.

For more information on triggering and to select the continuous trigger mode, see "[:TRIGger:TYPE](#)" on page 319.

The following list describes the waveform's response to each of the command choices:

FREE	Turning the ARB format on immediately triggers the waveform. The waveform repeats until you turn the format off, select another trigger, or choose another waveform file.
TRIGger	The waveform waits for a trigger before play begins. When the waveform receives the trigger, it plays continuously until you turn the format off, select another trigger, or choose another waveform file.
RESet	The waveform waits for a trigger before play begins. When the waveform receives the trigger, it plays continuously. Subsequent triggers reset the waveform to the beginning. For a waveform sequence, this means to the beginning of the first segment in the sequence.
*RST	FREE
Key Entry	Free Run Trigger & Run Reset & Run

:TRIGger:TYPE:GATE:ACTive

Supported E4438C with Option 001/601 or 002/602

```
[ :SOURce ] :RADio:ARB:TRIGger:TYPE:GATE:ACTive LOW | HIGH
[ :SOURce ] :RADio:ARB:TRIGger:TYPE:GATE:ACTive ?
```

This command selects the active state (gate polarity) of the gate while using the gating trigger mode.

The LOW and HIGH selections correspond to the low and high states of an external trigger signal. For example, when you select HIGH, the active state occurs during the high of the trigger signal. When the

Dual ARB Subsystem—Option 001/601 or 002/602 (:SOURce):RADio:ARB)

active state occurs, the ESG stops the waveform playback at the last played sample point, then restarts the playback at the next sample point when the inactive state occurs. For more information on triggering and to select gating as the trigger mode, see “:TRIGger:TYPE” on page 319.

The following list describes the ESG’s gating behavior for the polarity selections:

LOW	The waveform playback stops when the trigger signal goes low (active state) and restarts when the trigger signal goes high (inactive state).
HIGH	The waveform playback stops when the trigger signal goes high (active state) and restarts when the trigger signal goes low (inactive state).
*RST	HIGH
Key Entry	Gate Active Low High

:TRIGger:TYPE:SADVance[:TYPE]

Supported E4438C with Option 001/601 or 002/602

```
[ :SOURce ] :RADio:ARB:TRIGger:TYPE:SADVance [ :TYPE ] SINGLE | CONTinuous
[ :SOURce ] :RADio:ARB:TRIGger:TYPE:SADVance [ :TYPE ] ?
```

This command customizes the segment advance trigger type setting.

SINGLE	This choice will play the next segment in the sequence only once.
CONTinuous	This choice will instruct the sequencer to continually play the next segments in the waveform sequence in a continuous pattern.
*RST	CONT
Key Entry	Single Continuous
Remarks	This command is valid when SADVance has been selected as the trigger type. To select SADVance as the trigger type, refer to “:TRIGger:TYPE” on page 319.

:TRIGger:TYPE:SADVance[:TYPE]

Supported E4438C with Option 001/601 or 002/602

```
[ :SOURce ] :RADio:ARB:TRIGger:TYPE:SADVance [ :TYPE ] SINGLE | CONTinuous
[ :SOURce ] :RADio:ARB:TRIGger:TYPE:SADVance [ :TYPE ] ?
```

This command selects the waveform’s response to a trigger signal while using the segment advance (SADVance) trigger mode.

When the ESG receives multiple trigger occurrences when only one is required, the signal generator uses the first trigger and ignores the rest. For more information on triggering and to select segment advance as the trigger mode, see “:TRIGger:TYPE” on page 319.

The following list describes the waveform's response to each of the command choices:

- SINGLE** Each segment in the sequence requires a trigger to play, and a segment plays only once, ignoring a segment's repetition value (see “:SEQUence” on page 317 for repetition information). The following list describes a sequence's playback behavior with this choice:
- After receiving the first trigger, the first segment plays to completion.
 - When the waveform receives a trigger after a segment completes, the sequence advances to the next segment and plays that segment to completion.
 - When the waveform receives a trigger during play, the current segment plays to completion. Then the sequence advances to the next segment, and it plays to completion.
 - When the waveform receives a trigger either during or after the last segment in a sequence plays, the sequence resets and the first segment plays to completion.
- CONTInuous** Each segment in the sequence requires a trigger to play. After receiving a trigger, a segment plays continuously until the waveform receives another trigger. The following list describes a sequence's playback behavior with this choice:
- After receiving the first trigger, the first segment plays continuously.
 - A trigger during the current segment play causes the segment to play to the end of the segment file, then the sequence advances to the next segment, which plays continuously.
 - When last segment in the sequence receives a trigger, the sequence resets and the first segment plays continuously.

Example

```
:RAD:ARB:TRIG:TYPE:SADV CONT
```

The preceding example selects the continuous segment advance mode.

```
*RST          CONT
```

```
Key Entry    Single   Continuous
```

:TRIGger[:SOURce]

Supported E4438C with Option 001/601 or 002/602

[:SOURce]:RADio:ARB:TRIGger[:SOURce] KEY|EXT|BUS

[:SOURce]:RADio:ARB:TRIGger[:SOURce] ?

This command sets the trigger source.

For more information on triggering, see “:TRIGger:TYPE” on page 319. The following list describes the command choices:

KEY This choice enables manual triggering by pressing the front-panel **Trigger** hardkey.

EXT An externally applied signal triggers the waveform. This is the only choice that works with gating. The following conditions affect an external trigger:

- The input connector selected for the trigger signal. You have a choice between the rear-panel PATTERN TRIG IN connector or the PATT TRIG IN 2 pin on the rear-panel AUXILIARY I/O connector. To make the connector selection, see “:TRIGger[:SOURce]:EXTErnal[:SOURce]” on page 327.

For more information on the connectors and on connecting the cables, see the *E4428C/38C ESG Signal Generators User’s Guide*.

- The trigger signal polarity:
 - gating mode, see “:TRIGger:TYPE:GATE:ACTive” on page 321
 - continuous and single modes, see “:TRIGger[:SOURce]:EXTErnal:SLOPe” on page 326
- The delay between when the ESG receives a trigger and when the waveform responds to the trigger. There are two parts to setting the delay:
 - setting the amount of delay, see “:TRIGger[SOURce]:EXTErnal:DELAy[:TIME]” on page 326 or “:TRIGger[:SOURce]:EXTErnal:DELAy:SAMPles” on page 325
 - turning the delay on, see “:TRIGger[:SOURce]:EXTErnal:DELAy:STATE” on page 325

BUS This choice enables triggering over the GPIB or LAN using the *TRG or GET commands or the AUXILIARY INTERFACE (RS-232) using the *TRG command.

***RST** EXT

Key Entry Trigger Key Ext Bus

:TRIGger[:SOURce]:EXTeRnal:DELAy:SAMPles

Supported E4438C with Option 001/601 or 002/602

```
[ :SOURce ] :RADio:ARB:TRIGger [ :SOURce ] :EXTeRnal:DELAy:SAMPles <val>
[ :SOURce ] :RADio:ARB:TRIGger [ :SOURce ] :EXTeRnal:DELAy:SAMPles?
```

This command sets the number of samples to delay the ESG's response to an external trigger.

The delay is between when the ESG receives the trigger and when it responds to the trigger. For example, configuring a trigger delay of 100 samples, causes the ESG to wait 100 samples after receipt of the external trigger before the ESG plays the waveform. The delay does not occur until you select **SAMPles** as the delay type. For more information, see **“:TRIGger[:SOURce]:EXTeRnal:DELAy:STATe”** on page 325). You can set the delay value either before or after selecting **SAMPles**.

For more information on configuring an external trigger source and to select external as the trigger source, see **“:TRIGger[:SOURce]”** on page 324.

The unit of measurement for the variable <val> is in samples.

***RST** +0

Range 0–100E6

Key Entry Ext Delay Samples

:TRIGger[:SOURce]:EXTeRnal:DELAy:STATe OFF|ON|1|0

Supported E4438C with Option 001/601 or 002/602

NOTE Refer to the *Programming Compatibility Guide* for information on this command. This command was replaced by the **“:TRIGger[:SOURce]:EXTeRnal:DELAy:STATe”** command.

:TRIGger[:SOURce]:EXTeRnal:DELAy:STATe

Supported E4438C with Option 001/601 or 002/602

```
[ :SOURce ] :RADio:ARB:TRIGger [ :SOURce ] :EXTeRnal:DELAy:STATe OFF|TIME|
SAMPles
[ :SOURce ] :RADio:ARB:TRIGger [ :SOURce ] :EXTeRnal:DELAy:STATe?
```

This command enables the delay feature by selecting the external trigger delay type or disables the external trigger delay function.

Dual ARB Subsystem—Option 001/601 or 002/602 ([:SOURce]:RADio:ARB)

TIME Selects time as the delay value in units of nanoseconds to seconds. For setting the time delay value, see “[:TRIGger[SOURce]:EXTernal:DELay[:TIME]]” on page 326.

SAMPles Selects samples as the delay value. For setting the sample delay value, see “[:TRIGger[:SOURce]:EXTernal:DELay:SAMPles]” on page 325.

For information on configuring an external source, see “[:TRIGger[:SOURce]]” on page 324.

***RST** OFF

Key Entry Ext Delay Off Time Samples

:TRIGger[SOURce]:EXTernal:DELay[:TIME]

Supported E4438C with Option 001/601 or 002/602

```
[:SOURce]:RADio:ARB:TRIGger[:SOURce]:EXTernal:DELay[:TIME] <val>
```

```
[:SOURce]:RADio:ARB:TRIGger[:SOURce]:EXTernal:DELay[:TIME]?
```

This command sets the amount of time to delay the ESG’s response to an external trigger.

The delay is a path (time) delay between when the ESG receives the trigger and when it responds to the trigger. For example, configuring a trigger delay of two seconds, causes the ESG to wait two seconds after receipt of the trigger before the ESG plays the waveform. The delay does not occur until you select TIME as the delay type. For more information, see “[:TRIGger[:SOURce]:EXTernal:DELay:STATe]” on page 325. You can set the delay value either before or after selecting TIME.

For more information on configuring an external trigger source and to select external as the trigger source, see “[:TRIGger[:SOURce]]” on page 324.

The unit of measurement for the variable <val> is in seconds (nsec–sec).

***RST** +1.00000000E–003

Range 1E–8 to 4E1

Key Entry Ext Delay Time

:TRIGger[:SOURce]:EXTernal:SLOPe

Supported E4438C with Option 001/601 or 002/602

```
[:SOURce]:RADio:ARB:TRIGger[:SOURce]:EXTernal:SLOPe POSitive|NEGative
```

```
[:SOURce]:RADio:ARB:TRIGger[:SOURce]:EXTernal:SLOPe?
```

This command sets the polarity for an external trigger signal while using the continuous, single triggering mode. To set the polarity for gating, see “[:TRIGger:TYPE:GATE:ACTive]” on page 321.

Dual ARB Subsystem—Option 001/601 or 002/602 (:SOURce):RADio:ARB)

The POSitive and NEGative selections correspond to the high (positive) and low (negative) states of the external trigger signal. For example, when you select POSitive, the waveform responds (plays) during the high state of the trigger signal. When the ESG receives multiple trigger occurrences when only one is required, the signal generator uses the first trigger and ignores the rest.

For more information on configuring an external trigger source and to select external as the trigger source, see “:TRIGger[:SOURce]” on page 324.

*RST	NEG
Key Entry	Ext Polarity Neg Pos

:TRIGger[:SOURce]:EXTernal[:SOURce]

Supported E4438C with Option 001/601 or 002/602

```
[ :SOURce ] :RADio:ARB:TRIGger [ :SOURce ] :EXTernal [ :SOURce ] EPT1 | EPT2 |
EPTRIGGER1 | EPTRIGGER2
[ :SOURce ] :RADio:ARB:TRIGger [ :SOURce ] :EXTernal [ :SOURce ] ?
```

This command selects which PATTERN TRIG IN connection the ESG uses to accept an externally applied trigger signal when external is the trigger source selection.

For more information on configuring an external trigger source and to select external as the trigger source, see “:TRIGger[:SOURce]” on page 324. For more information on the rear-panel connectors, see the *E4428C/38C ESG Signal Generators User’s Guide*.

The following list describes the command choices:

EPT1	This choice is synonymous with EPTRIGGER1 and selects the PATTERN TRIG IN rear-panel connector.
EPT2	This choice is synonymous with EPTRIGGER2 and selects the PATT TRIG IN 2 pin on the rear-panel AUXILIARY I/O connector.
EPTRIGGER1	This choice is synonymous with EPT1 and selects the PATTERN TRIG IN rear-panel connector.
EPTRIGGER2	This choice is synonymous with EPT2 and selects the PATT TRIG IN 2 pin on the rear-panel AUXILIARY I/O connector.
*RST	EPT1
Key Entry	Patt Trig In 1 Patt Trig In 2

:WAVeform

Supported E4438C with Option 001/601 or 002/602

```
[ :SOURce ] :RADio:ARB:WAVeform "WFM1:file_name" | "SEQ:file_name"
```

Dual ARB Subsystem—Option 001/601 or 002/602 ([:SOURce]:RADio:ARB)

```
[:SOURce]:RADio:ARB:WAVeform?
```

This command selects a waveform file or sequence, for the dual ARB player to play. The file must be present in volatile memory, WFM1, or in the SEQ directory. If a file is in non-volatile memory (NVWFM), use the command “:COPY[:NAME]” on page 105 to copy the file to WFM1.

"WFM1:file_name" This variable names a waveform file residing in volatile memory (WFM1:). For information on the file name syntax, see “File Name Variables” on page 13.

"SEQ:file_name" This variable names a sequence file residing in the catalog of sequence files. For more information on the file name syntax, see “File Name Variables” on page 13.

Example

```
:RAD:ARB:WAV "WFM1:Test_Data"
```

The preceding example selects the file Test_Data from the list of files in volatile waveform memory, WFM1, and applies its file header settings.

Key Entry **Select Waveform**

:Waveform:NHEAders

Supported E4438C with Option 001/601 or 002/602

```
[:SOURce]:RADio:ARB:WAVeform:NHEAders "WFM1:file_name" | "SEQ:filename"  
[:SOURce]:RADio:ARB:WAVeform:NHEAders?
```

This command, for the dual ARB mode, allows for a fast selection of a segment or sequence waveform file. No header information or settings are applied to the segment or sequence waveform file when this command is used. This will improve the access or loading speed of the waveform file to approximately 100 mS for a single segment. The file must be in volatile waveform memory (WFM1), or in the SEQ directory. If a file is in non-volatile waveform memory (NVWFM), use the command “:COPY[:NAME]” on page 105 to copy files to WFM1.

"WFM1:file_name" This variable names a waveform file residing in volatile memory:WFM1. For information on the file name syntax, see “File Name Variables” on page 13.

"SEQ:filename" This variable names a sequence file residing in the catalog of sequence files. For more information on the file name syntax, see “File Name Variables” on page 13.

Example

```
:RAD:ARB:WAV:NHEA "Test_Data"
```

The preceding example selects the file Test_Data, without applying header settings.

[:STATe]

Supported E4438C with Option 001/601 or 002/602

Dual ARB Subsystem—Option 001/601 or 002/602 (:SOURce):RADio:ARB)

```
[ :SOURce ] :RADio:ARB [ :STATe ] ON | OFF | 1 | 0  
[ :SOURce ] :RADio:ARB [ :STATe ] ?
```

This command enables or disables the arbitrary waveform generator function.

***RST** 0

Key Entry **ARB Off On**

Multitone Subsystem—Option 001/601 or 002/602 ([:SOURCE]:RADio:MTONE:ARB)

Creating a Multitone Waveform

Use the following steps to create a multitone waveform:

1. Initialize the phase for the multitone waveform. Refer to “:SETup:TABLE:PHASe:INITialize” on page 342.
2. Assign the frequency spacing between the tones. Refer to “:SETup:TABLE:FSPacing” on page 341.
3. Define the number of tones within the waveform. Refer to “:SETup:TABLE:NTONes” on page 341.
4. Modify the power level, phase, and state of any individual tones. Refer to “:ROW” on page 338.

:HEADer:CLEar

Supported E4438C with Option 001/601 or 002/602

[[:SOURCE]:RADio:MTONE:ARB:HEADer:CLEar

This command clears the header information from the file header used by this modulation format.

Key Entry Clear Header

Remarks The **Multitone Off On** softkey must be set to On for this command to function.

:HEADer:SAVE

Supported E4438C with Option 001/601 or 002/602

[[:SOURCE]:RADio:MTONE:ARB:HEADer:SAVE

This command saves the header information to the file header used by this modulation format.

Key Entry Save Setup To Header

Remarks The **Multitone Off On** softkey must be set to On for this command to function.

:IQ:EXTeRnal:FiLTeR**Supported** E4438C with Option 001/601 or 002/602

[:SOURce]:RADio:MTONE:ARB:IQ:EXTeRnal:FiLTeR 40e6 | THRough

[:SOURce]:RADio:MTONE:ARB:IQ:EXTeRnal:FiLTeR?

This command selects the filter or through path for I/Q signals routed to the rear panel I and Q outputs. Selecting a filter using this command will automatically set “:IQ:EXTeRnal:FiLTeR:AUTO” on [page 331](#) to OFF(0) mode.

40e6 This choice applies a 40 MHz baseband filter.

THRough This choice bypasses filtering.

RST** THR**Key Entry** 40.000 MHz Through**:IQ:EXTeRnal:FiLTeR:AUTO*Supported** E4438C with Option 001/601 or 002/602

[:SOURce]:RADio:MTONE:ARB:IQ:EXTeRnal:FiLTeR:AUTO ON | OFF | 1 | 0

[:SOURce]:RADio:MTONE:ARB:IQ:EXTeRnal:FiLTeR:AUTO?

This command enables or disables the automatic selection of the filters for I/Q signals routed to the rear panel I/Q outputs.

ON(1) This choice will automatically select a digital modulation filter optimized for the current signal generator settings.

OFF(0) This choice disables the auto feature which lets you select a digital modulation filter or through path. Refer to “:IQ:EXTeRnal:FiLTeR” on [page 331](#) for selecting a filter or through path.***RST** 1**Key Entry** I/Q Output Filter Manual Auto

:IQ:MODulation:ATTen

Supported E4438C with Option 001/601 or 002/602

```
[ :SOURce ] :RADio:MTONE:ARB:IQ:MODulation:ATTen <val>
```

```
[ :SOURce ] :RADio:MTONE:ARB:IQ:MODulation:ATTen?
```

This command attenuates the I/Q signals being modulated through the signal generator RF path.

The variable <val> is expressed in units of decibels (dB).

***RST** +2.00000000E+000

Range 0–40

Key Entry Modulator Atten Manual Auto

:IQ:MODulation:ATTen:AUTO

Supported E4438C with Option 001/601 or 002/602

```
[ :SOURce ] :RADio:MTONE:ARB:IQ:MODulation:ATTen:AUTO ON|OFF|1|0
```

```
[ :SOURce ] :RADio:MTONE:ARB:IQ:MODulation:ATTen:AUTO?
```

This command enables or disables the I/Q attenuation auto mode.

ON (1) This choice enables the attenuation auto mode which optimizes the modulator attenuation for the current conditions.

OFF (0) This choice holds the attenuator at its current setting or at a selected value. Refer to “[:IQ:MODulation:ATTen](#)” on page 332 for setting the attenuation value.

***RST** 1

Key Entry Modulator Atten Manual Auto

:IQ:MODulation:FILTer

Supported E4438C with Option 001/601 or 002/602

```
[ :SOURce ] :RADio:MTONE:ARB:IQ:MODulation:FILTer 2.1e6 | 40e6 | THROugh
[ :SOURce ] :RADio:MTONE:ARB:IQ:MODulation:FILTer?
```

This command enables you to select a filter or through path for I/Q signals modulated onto the RF carrier. Selecting a filter using this command will automatically set “:IQ:MODulation:FILTer:AUTO” on page 333 to OFF(0) mode.

2.1E6 This choice applies a 2.1 MHz baseband filter to the I/Q signals.

40E6 This choice applies a 40 MHz baseband filter to the I/Q signals.

THROugh This choice bypasses filtering.

***RST** THR

Key Entry 2.100 MHz 40.000 MHz Through

:IQ:MODulation:FILTer:AUTO

Supported E4438C with Option 001/601 or 002/602

```
[ :SOURce ] :RADio:MTONE:ARB:IQ:MODulation:FILTer:AUTO ON | OFF | 1 | 0
[ :SOURce ] :RADio:MTONE:ARB:IQ:MODulation:FILTer:AUTO?
```

This command enables or disables the automatic selection of the filters for I/Q signals modulated onto the RF carrier.

ON(1) This choice will automatically select a digital modulation filter.

OFF(0) This choice disables the auto feature which lets you select a digital modulation filter or through path. Refer to “:IQ:MODulation:FILTer” on page 333 for selecting a filter or through path.

***RST** 1

Key Entry I/Q Mod Filter Manual Auto

:MDEStination:AAMPlitude

Supported E4438C with Option 001/601 or 002/602

```
[ :SOURce ] :RADio:MTONE:ARB:MDEStination:AAMPlitude NONE | M1 | M2 | M3 | M4
[ :SOURce ] :RADio:MTONE:ARB:MDEStination:AAMPlitude?
```

This command routes the selected marker to the Alternate Amplitude function. The NONE parameter clears the marker for the Alternate Amplitude function.

Multitone Subsystem—Option 001/601 or 002/602 ([:SOURCE]:RADio:MTONE:ARB)

*RST NONE
 Key Entry None Marker 1 Marker 2 Marker 3 Marker 4

:MDEStination:ALCHold

Supported E4438C with Option 001/601 or 002/602

CAUTION Incorrect automatic level control (ALC) sampling can create a sudden unlevelled condition that may create a spike in the RF output potentially damaging a DUT or connected instrument. Ensure that you set markers to let the ALC sample over an amplitude that accounts for the high power levels within the signal.

```
[ :SOURce ] :RADio:MTONE:ARB:MDEStination:ALCHold NONE | M1 | M2 | M3 | M4
[ :SOURce ] :RADio:MTONE:ARB:MDEStination:ALCHold?
```

This command enables or disables the marker ALC hold function for the selected marker. For setting markers, see “:MARKer:[SET]” on page 306.

Use the ALC hold function when you have a waveform signal that incorporates idle periods, or when the increased dynamic range encountered with RF blanking is not desired. The ALC leveling circuitry responds to the marker signal during the marker pulse (marker signal high), averaging the modulated signal level during this period.

The ALC hold function operates during the low periods of the marker signal. The marker polarity determines when the marker signal is high. For a positive polarity, this is during the marker points. For a negative polarity, this is when there are no marker points. For setting a marker’s polarity, see “:MPOLarity:MARKer1|2|3|4” on page 337.

NOTE Do not use the ALC hold for more than 100 ms, because it can affect the waveform’s output amplitude.

The marker signal has a minimum of a two-sample delay in its response relative to the waveform signal response. To compensate for the marker signal delay, offset marker points from the waveform sample point at which you want the ALC sampling to begin.

The ALC hold setting is part of the file header information, so saving the setting to the file header saves the current marker routing for the waveform file.

NOTE A waveform file that has unspecified settings in the file header uses the previous waveform’s routing settings.

Multitone Subsystem—Option 001/601 or 002/602 ([:SOURce]:RADio:MTONE:ARB)

For more information on the marker ALC hold function, see the *E4428C/38C ESG Signal Generators User's Guide*. For setting the marker points, see “:MARKer:[SET]” on page 306.

NONE	This terminates the marker ALC hold function.
M1–M4	These are the marker choices. The ALC hold feature uses only one marker at a time.
*RST	NONE

Example

```
:RAD:AWGB:ARB:MDES:ALCH M1
```

The preceding example routes marker 1 to the ALC Hold function.

Key Entry	None	Marker 1	Marker 2	Marker 3	Marker 4
Remarks	N/A				

:MDEStination:PULSe

Supported E4438C with Option 001/601 or 002/602

CAUTION The pulse function incorporates ALC hold. Incorrect automatic level control (ALC) sampling can create a sudden unlevelled condition that may create a spike in the RF output potentially damaging a DUT or connected instrument. Ensure that you set markers to let the ALC sample over an amplitude that accounts for the high power levels within the signal.

```
[[:SOURce]:RADio:MTONE:ARB:MDEStination:PULSe NONE | M1 | M2 | M3 | M4  
[:SOURce]:RADio:MTONE:ARB:MDEStination:PULSe?
```

This command enables or disables the marker pulse/RF blanking function for the selected marker.

This function automatically incorporates the ALC hold function, so there is no need to select both the ALC hold and pulse/RF blanking functions for the same marker.

NOTE Do not use ALC hold for more than 100 ms, because it can affect the waveform's output amplitude.

The signal generator blanks the RF output when the marker signal goes low. The marker polarity determines when the marker signal is low. For a positive polarity, this is during the marker points. For a negative polarity, this is when there are no marker points. For setting a marker's polarity, see

“:MPOLarity:MARKer1|2|3|4” on page 337.

NOTE Set marker points prior to using this function. Enabling this function without setting marker points may create a continuous low or high marker signal, depending on the marker polarity. This causes either no RF output or a continuous RF output. See “:MARKer:[SET]” on page 306 for setting the marker points.

The marker signal has a minimum of a two-sample delay in its response relative to the waveform signal response. To compensate for the marker signal delay, offset marker points from the waveform sample point at which you want the RF blanking to begin. The RF blanking setting is part of the file header information, so saving the setting to the file header saves the current marker routing for the waveform file.

NOTE A waveform file that has unspecified settings in the file header uses the previous waveform’s routing settings. This could create the situation where there is no RF output signal, because the previous waveform used RF blanking.

For more information on the marker RF blanking function, see the *E4428C/38C ESG Signal Generators User’s Guide*.

NONE This terminates the marker RF blanking/pulse function.

M1–M4 These are the marker choices. The RF blanking/pulse feature uses only one marker at a time.

Example

```
:RAD:ARB:MDES:PULS M2
```

The preceding example routes marker 2 to Pulse/RF Blanking.

```
*RST NONE
```

Key Entry	None	Marker 1	Marker 2	Marker 3	Marker 4
------------------	-------------	-----------------	-----------------	-----------------	-----------------

Multitone Subsystem—Option 001/601 or 002/602 (:SOURce):RADio:MTONE:ARB)**:MPOLarity:MARKer1|2|3|4**

Supported E4438C with Option 001/601 or 002/602

```
[ :SOURce ] :RADio:MTONE:ARB:MPOLarity:MARKer1 | 2 | 3 | 4 NEGative | POSitive
[ :SOURce ] :RADio:MTONE:ARB:MPOLarity:MARKer1 | 2 | 3 | 4 ?
```

This command sets the polarity for the selected marker. For a positive marker polarity, the marker signal is high during the marker points. For a negative marker polarity, the marker signal is high during the period of no marker points.

***RST** POS

Key Entry	Marker 1 Polarity Neg	Marker 2 Polarity Neg	Marker 3 Polarity Neg
	Pos	Pos	Pos
	Marker 4 Polarity Neg Pos		

:REFerence:EXTernal:FREQuency

Supported E4438C with Option 001/601 or 002/602

```
[ :SOURce ] :RADio:MTONE:ARB:REFerence:EXTernal:FREQuency <val>
[ :SOURce ] :RADio:MTONE:ARB:REFerence:EXTernal:FREQuency ?
```

This command allows you to enter the frequency of the applied external reference.

The variable <val> is expressed in units of Hertz (Hz–MHz).

***RST** +1.00000000E+007

Range 2.5E5–1E8

Key Entry Reference Freq

Remarks The value specified by this command is effective only when you are using an external ARB reference applied to the BASEBAND GEN REF IN rear panel connector.

To specify external as the ARB reference source type, refer to “:REFerence[:SOURce]” on page 337.

:REFerence[:SOURce]

Supported E4438C with Option 001/601 or 002/602

```
[ :SOURce ] :RADio:MTONE:ARB:REFerence [ :SOURce ] INTernal | EXTernal
[ :SOURce ] :RADio:MTONE:ARB:REFerence [ :SOURce ] ?
```

This command selects either an internal or external reference for the waveform clock.

Multitone Subsystem—Option 001/601 or 002/602 ([:SOURce]:RADio:MTONE:ARB)

*RST	INT
Key Entry	ARB Reference Ext Int
Remarks	<p>If the EXTERNAL choice is selected, the external frequency <i>value must</i> be entered and the signal must be applied to the BASEBAND GEN REF IN rear panel connector.</p> <p>Refer to “[:REfERENCE:EXtERnal:FREquency]” on page 337 to enter the external reference frequency.</p>

:ROW

Supported	E4438C with Option 001/601 or 002/602
	<pre>[:SOURce]:RADio:MTONE:ARB:SETup:TABLE:ROW <row_number>,<power>,<phase>,<state> [:SOURce]:RADio:MTONE:ARB:SETup:TABLE:ROW? <row_number></pre>
	This command modifies the indicated tone (row) of the multitone waveform.
<row_number>	The number of rows for this variable are determined by the :SETup:TABLE command.
	The variable <power> is expressed in units of decibels (dB).
	The variable <phase> is expressed in units of degrees (deg).
	Frequency offset, power, phase, and state value are returned when a query is initiated. The output format is as follows:
	<pre><frequency offset>,<power>,<phase>,<state></pre>
*RST	<pre>frequency offset: -3.50000000E+004 <power>: +0.00000000E+000 <phase>: +0.00000000E+000 <state>: 1</pre>
Range	<pre>frequency offset: -4E7 to 4E7 <power>: -80 to 0 <phase>: 0-359 <state>: 1</pre>
Key Entry	Goto Row Toggle State
Remarks	<p>Refer to “[:SETup:TABLE]” on page 340 for information on how to change the number of rows.</p> <p>This command is the final step in creating a multitone waveform. Refer to “Creating a Multitone Waveform” on page 330 for all four steps.</p>

Multitone Subsystem—Option 001/601 or 002/602 (:SOURce):RADio:MTONE:ARB)**:RSCAling**

Supported E4438C with Option 001/601 or 002/602

```
[ :SOURce ] :RADio:MTONE:ARB:RSCAling <val>
```

```
[ :SOURce ] :RADio:MTONE:ARB:RSCAling?
```

This command adjusts the scaling value that is applied to the Multitone waveform while it is playing. The variable <val> is expressed as a percentage. Runtime scaling does not alter the waveform data file. For more information about runtime scaling, refer to the *E4428C/38C ESG Signal Generators User's Guide*.

Example

```
:RAD:MTON:ARB:RSC 50
```

The preceding example applies a 50% scaling factor to the selected waveform.

```
*RST +7.00000000E+001
```

Range 1–100

Key Entry **Waveform Runtime Scaling**

Remarks Runtime scaling does not alter the waveform data file.

:SCLock:RATE

Supported E4438C with Option 001/601 or 002/602

```
[ :SOURce ] :RADio:MTONE:ARB:SCLock:RATE <val>
```

```
[ :SOURce ] :RADio:MTONE:ARB:SCLock:RATE?
```

This command sets the sample clock rate for the Multitone modulation format.

The variable <val> is expressed in units of hertz.

```
*RST +1.00000000E+008
```

Range 1–1E8

Key Entry **ARB Sample Clock**

Remarks The modulation format should be active before executing this command. If this command is executed before the modulation format is active, the entered value will be overridden by a calculated factory default value. Refer to “[:STATe]” on [page 343](#) to activate the modulation format.

Multitone Subsystem—Option 001/601 or 002/602 ([:SOURCE]:RADio:MTONE:ARB)

:SETup

Supported E4438C with Option 001/601 or 002/602

```
[ :SOURCE ] :RADio:MTONE:ARB:SETup "<file name>"
[ :SOURCE ] :RADio:MTONE:ARB:SETup?
```

This command retrieves a multitone waveform file.

Key Entry Load From Selected File

Remarks The name of a multitone waveform file is stored in the signal generator file system of MTONE files. This information is held in memory until you send the command that turns the waveform on.

Refer to “File Name Variables” on page 13 for information on the file name syntax.

:SETup:STORE

Supported E4438C with Option 001/601 or 002/602

```
[ :SOURCE ] :RADio:MTONE:ARB:SETup:STORE "<file name>"
```

This command stores the current multitone waveform setup in the signal generator file system of MTONE files.

Key Entry Store To File

:SETup:TABLE

Supported E4438C with Option 001/601 or 002/602

```
[ :SOURCE ] :RADio:MTONE:ARB:SETup:TABLE <freq_spacing>,
<num_tones>, {<phase>, <state>}
[ :SOURCE ] :RADio:MTONE:ARB:SETup:TABLE?
```

This command creates and configures a multitone waveform.

The frequency offset, power, phase, and state value are returned when a query is initiated. The output format is as follows:

<frequency offset>, <power>, <phase>, <state>

The variable <freq_spacing> is expressed in units of Hertz (Hz–MHz).

The variable <power> is expressed in units of decibels (dB).

*RST	Tone	<frequency offset>	<power>	<phase>	<state>
	Tone 1	-35000	+0.00000000E+000	+0	+1
	Tone 2	-25000	+0.00000000E+000	+0	+1

Multitone Subsystem—Option 001/601 or 002/602 ([:SOURce]:RADio:MTONE:ARB)

*RST	Tone	<frequency offset>	<power>	<phase>	<state>
	Tone 3	-15000	+0.00000000E+000	+0	+1
	Tone 4	-5000	+0.00000000E+000	+0	+1
	Tone 5	+5000	+0.00000000E+000	+0	+1
	Tone 6	+15000	+0.00000000E+000	+0	+1
	Tone 7	+25000	+0.00000000E+000	+0	+1
	Tone 8	+35000	+0.00000000E+000	+0	+1

Range <freq_spacing> (2 tones): 1E4–8E7 <num_tones>: 2–64
 <freq_spacing> (>2 tones): 1E4 to (80 MHz ÷ (num_tones – 1))
 <phase>: 0–359

Key Entry Freq Spacing Number Of Tones Toggle State

Remarks To set the frequency spacing, refer to “:SETup:TABLE:FSPacing” on page 341.

:SETup:TABLE:FSPacing

Supported E4438C with Option 001/601 or 002/602

```
[ :SOURce ] :RADio:MTONE:ARB:SETup:TABLE:FSPacing <freq_spacing>
[ :SOURce ] :RADio:MTONE:ARB:SETup:TABLE:FSPacing?
```

This command sets the frequency spacing between the tones.

The variable <freq_spacing> is expressed in units of Hertz (Hz–MHz).

***RST** +1.00000000E+004

Range <freq_spacing> (2 tones): 1E4–8E7
 <freq_spacing> (>2 tones): 1E4 to (80 MHz ÷ (num_tones – 1))

Key Entry Freq Spacing

Remarks To set frequency spacing and additional parameters required to create or configure a multitone waveform, refer to “:SETup:TABLE” on page 340.

This command is the second step in creating a multitone waveform. Refer to “Creating a Multitone Waveform” on page 330 for all four steps.

:SETup:TABLE:NTONES

Supported E4438C with Option 001/601 or 002/602

```
[ :SOURce ] :RADio:MTONE:ARB:SETup:TABLE:NTONES <num_tones>
[ :SOURce ] :RADio:MTONE:ARB:SETup:TABLE:NTONES?
```

This command defines the number of tones in the multitone waveform.

***RST** +8

Multitone Subsystem—Option 001/601 or 002/602 ([:SOURce]:RADio:MTONE:ARB)

Range	2–64
Key Entry	Number Of Tones
Remarks	To specify the number of tones and additional parameters required to create or configure a multitone waveform, refer to “:SETup:TABLE” on page 340. This command is the third step in creating a multitone waveform. Refer to “Creating a Multitone Waveform” on page 330 for all four steps.

:SETup:TABLE:PHASe:INITialize

Supported	E4438C with Option 001/601 or 002/602
	<code>[:SOURce] :RADio:MTONE:ARB:SETup:TABLE:PHASe:INITialize FIXed RANDOM</code> <code>[:SOURce] :RADio:MTONE:ARB:SETup:TABLE:PHASe:INITialize?</code>
	This command initializes the phase in the multitone waveform table.
FIXed	This choice sets the phase of all tones to the fixed value of 0 degrees.
RANDOM	This choice sets the phase of all tones to random values based on the setting on the random seed generator.
*RST	FIX
Key Entry	Initialize Phase Fixed Random
Remarks	To change the random number generator seed value, refer to “:SETup:TABLE:PHASe:INITialize:SEED” on page 342. This command is the first step in creating a multitone waveform. Refer to “Creating a Multitone Waveform” on page 330 for all four steps.

:SETup:TABLE:PHASe:INITialize:SEED

Supported	E4438C with Option 001/601 or 002/602
	<code>[:SOURce] :RADio:MTONE:ARB:SETup:TABLE:PHASe:INITialize:SEED FIXed RANDOM</code> <code>[:SOURce] :RADio:MTONE:ARB:SETup:TABLE:PHASe:INITialize:SEED?</code>
	This command initializes the random number generator seed that is used to generate the random phase values for the multitone waveform.
FIXed	This choice sets the random number generator seed to a fixed value.
RANDOM	This choice sets the random number generator seed to a random value. This changes the phase value after each initialization of the phase.
*RST	FIX

Multitone Subsystem—Option 001/601 or 002/602 (:SOURce):RADio:MTONE:ARB)

Key Entry **Random Seed Fixed Random**

[:STATe]

Supported E4438C with Option 001/601 or 002/602

[:SOURce]:RADio:MTONE:ARB[:STATe] ON|OFF|1|0

[:SOURce]:RADio:MTONE:ARB[:STATe] ?

This command enables or disables the multitone waveform generator function.

***RST** 0

Key Entry **Multitone Off On**

Wideband CDMA ARB Subsystem–Option 400 ([:SOURce]:RADio:WCDMa:TGPP:ARB)

:CLIPping:I

Supported E4438C with Option 400

[:SOURce] :RADio:WCDMa:TGPP:ARB:CLIPping:I <val>

[:SOURce] :RADio:WCDMa:TGPP:ARB:CLIPping:I?

This command limits the modulation level of the waveform's I component to a percentage of full scale.

The variable <val> is expressed in units of percent.

***RST** +1.00000000E+002

Range 10–100

Key Entry Clip |I| To

:CLIPping:POSition

Supported E4438C with Option 400

[:SOURce] :RADio:WCDMa:TGPP:ARB:CLIPping:POSition PRE | POST

[:SOURce] :RADio:WCDMa:TGPP:ARB:CLIPping:POSition?

This command specifies whether a waveform is clipped before (PRE) or after (POST) FIR filtering.

***RST** PRE

Key Entry Clip At PRE POST FIR Filter

:CLIPping:Q

Supported E4438C with Option 400

[:SOURce] :RADio:WCDMa:TGPP:ARB:CLIPping:Q <val>

[:SOURce] :RADio:WCDMa:TGPP:ARB:CLIPping:Q?

This command limits the modulation level of the waveform's Q component to a percentage of full scale.

The variable <val> is expressed in units of percent.

Wideband CDMA ARB Subsystem–Option 400 ([:SOURce]:RADio:WCDMa:TGPP:ARB)

***RST** +1.00000000E+002

Range 10–100

Key Entry Clip |Q| To

:CLIPping:TYPE

Supported E4438C with Option 400

[:SOURce]:RADio:WCDMa:TGPP:ARB:CLIPping:TYPE IJQ| IORQ

[:SOURce]:RADio:WCDMa:TGPP:ARB:CLIPping:TYPE?

This command selects either IJQ or IORQ as the clipping type.

IJQ The combined I and Q waveform will be clipped (*circular* clipping).

IORQ The I and Q components of the waveform are clipped independently (*rectangular* clipping). I and Q can be clipped to different levels using this mode.

***RST** IJQ

Key Entry Clipping Type |I+jQ| |I|,|Q|

:CLIPping[:IJQ]

Supported E4438C with Option 400

[:SOURce]:RADio:WCDMa:TGPP:ARB:CLIPping[:IJQ] <val>

[:SOURce]:RADio:WCDMa:TGPP:ARB:CLIPping[:IJQ] ?

This command clips (limits) the modulation level of the combined I and Q waveform to a percentage of full scale.

The variable <val> is expressed in units of percent.

***RST** +1.00000000E+002

Range 10–100

Key Entry Clip |I+jQ| To

:CRATe

Supported E4438C with Option 400

[:SOURCE]:RADio:WCDMa:TGPP:ARB:CRATe <val>

[:SOURCE]:RADio:WCDMa:TGPP:ARB:CRATe?

This command sets the chip rate value.

***RST** +3.84000000E+006

Range 3456000–4224000

Key Entry **Chip Rate**

:FILTer

Supported E4438C with Option 400

[:SOURCE]:RADio:WCDMa:TGPP:ARB:FILTer RNYquist|NYquist|GAUSSian|RECTangle|WCDMA|AC4Fm|IS2000SR3DS|UGGaussian|"<user FIR>"

[:SOURCE]:RADio:WCDMa:TGPP:ARB:FILTer?

This command selects the pre-modulation filter type.

WCDMA This choice selects a 0.22 Nyquist filter optimized for ACP.

AC4Fm This choice selects a predefined Association of Public Safety Communications Officials (APCO) specified compatible 4-level frequency modulation (C4FM) filter.

IS2000SR3DS This choice selects an IS-2000 standard, spread rate 3 direct spread filter.

UGGaussian This choice selects a backwards compatible GSM Gaussian filter (Gaussian filter with a fixed BbT value of 0.300) for the ESG E44xxB Option UN3 or UN4.

"<user FIR>" This variable is any FIR filter file that you have stored in memory. The variable needs no directory path indicating the location of the file, such as FIR: or /USER/FIR. The command assumes the FIR directory. Refer to [“File Name Variables” on page 13](#) for more information on file names.

***RST** NYQ

Key Entry	Root Nyquist	Nyquist	Gaussian	Rectangle	WCDM A
	APCO 25 C4FM	IS-95	UN3/4 GSM Gaussian	IS-2000 SR3 DS	
	User FIR				

Wideband CDMA ARB Subsystem–Option 400 ([:SOURCE]:RADIO:WCDMA:TGPP:ARB)

:FILTER:ALPHA

Supported E4438C with Option 400

[:SOURCE] :RADIO:WCDMA:TGPP:ARB:FILTER:ALPHA <val>

[:SOURCE] :RADIO:WCDMA:TGPP:ARB:FILTER:ALPHA?

This command sets the alpha value for the Nyquist or root Nyquist filter.

The filter alpha value can be set to the minimum level (0), the maximum level (1), or in between by using fractional numeric values (0.001–0.999).

***RST** +2.20000000E–001

Range 0.000–1.000

Key Entry **FiLter Alpha**

Remarks To change the current filter type, refer to “:FILTER” on page 346.

:FILTER:BBT

Supported E4438C with Option 400

[:SOURCE] :RADIO:WCDMA:TGPP:ARB:FILTER:BBT <val>

[:SOURCE] :RADIO:WCDMA:TGPP:ARB:FILTER:BBT?

This command changes the bandwidth-multiplied-by-bit-time (BbT) filter parameter.

The filter BbT value can be set to the minimum level (0), the maximum level (1), or in between by using fractional numeric values (0.001–0.999).

***RST** +5.00000000E–001

Range 0.000–1.000

Key Entry **Filter BbT**

Remarks This command is effective only after choosing a Gaussian filter. It does not have an effect on other types of filters.

To change the current filter type, refer to “:FILTER” on page 346.

:FILTer:CHANnel

Supported E4438C with Option 400

```
[ :SOURCE ] :RADio:WCDMa:TGPP:ARB:FILTer:CHANnel EVM|ACP  
[ :SOURCE ] :RADio:WCDMa:TGPP:ARB:FILTer:CHANnel?
```

This command optimizes the Nyquist and root Nyquist filters to minimize error vector magnitude (EVM) or to minimize adjacent channel power (ACP).

EVM This choice provides the most ideal passband.

ACP This choice improves stopband rejection.

***RST** ACP

Key Entry **Optimize FIR For EVM ACP**

Remarks To change the current filter type, refer to “:FILTer” on page 346.

:HEADer:CLEar

Supported E4438C with Option 400

```
[ :SOURCE ] :RADio:WCDMa:TGPP:ARB:HEADer:CLEar
```

This command clears the header information from the file header used by this modulation format.

Key Entry **Clear Header**

Remarks The **W-CDMA Off On** softkey must be set to On for this command to function.

:HEADer:SAVE

Supported E4438C with Option 400

```
[ :SOURCE ] :RADio:WCDMa:TGPP:ARB:HEADer:SAVE
```

This command saves the header information to the file header used by this modulation format.

Key Entry **Save Setup To Header**

Remarks The **W-CDMA Off On** softkey must be set to On for this command to function.

:IQ:EXTErnal:FILTer

Supported E4438C with Option 400

```
[ :SOURCE ] :RADio:WCDMa:TGPP:ARB:IQ:EXTErnal:FILTer 40e6|THROUGH  
[ :SOURCE ] :RADio:WCDMa:TGPP:ARB:IQ:EXTErnal:FILTer?
```

Wideband CDMA ARB Subsystem–Option 400 (:SOURce):RADio:WCDMa:TGPP:ARB)

This command selects the filter or through path for I/Q signals routed to the rear panel I and Q outputs. Selecting a filter using this command will automatically set “:IQ:EXtErnal:FILTer:AUTO” on page 349 to OFF(0) mode.

40e6 This choice applies a 40 MHz baseband filter.

THRough This choice bypasses filtering.

*RST THR

Key Entry 40.000 MHz Through

:IQ:EXtErnal:FILTer:AUTO

Supported E4438C with Option 400

[:SOURce] :RADio:WCDMa:TGPP:ARB:IQ:EXtErnal:FILTer:AUTO ON|OFF|1|0

[:SOURce] :RADio:WCDMa:TGPP:ARB:IQ:EXtErnal:FILTer:AUTO?

This command enables or disables the automatic selection of the filters for I/Q signals routed to the rear panel I/Q outputs.

ON(1) This choice will automatically select a digital modulation filter optimized for the current signal generator settings.

OFF(0) This choice disables the auto feature which lets you select a digital modulation filter or through path. Refer to “:IQ:EXtErnal:FILTer” on page 348 for selecting a filter or through path.

*RST 1

Key Entry I/Q Output Filter Manual Auto

:IQMap

Supported E4438C with Option 400

[:SOURce] :RADio:WCDMa:TGPP:ARB:IQMap NORMal|INVert

[:SOURce] :RADio:WCDMa:TGPP:ARB:IQMap?

This command selects whether or not the I/Q outputs will be inverted.

NORMal This choice selects normal polarity.

INVerted This choice inverts the internal Q signal.

*RST NORM

Key Entry I/Q Mapping Normal Invert

:IQ:MODulation:ATTen

Supported E4438C with Option 400

```
[:SOURCE]:RADio:WCDMa:TGPP:ARB:IQ:MODulation:ATTen <val>
[:SOURCE]:RADio:WCDMa:TGPP:ARB:IQ:MODulation:ATTen?
```

This command attenuates the I/Q signals being modulated through the signal generator RF path.

The variable <val> is expressed in units of decibels (dB).

***RST** +2.00000000E+00

Range 0–40

Key Entry **Modulator Atten Manual Auto**

:IQ:MODulation:ATTen:AUTO

Supported E4438C with Option 400

```
[:SOURCE]:RADio:WCDMa:TGPP:ARB:IQ:MODulation:ATTen:AUTO ON|OFF|1|0
[:SOURCE]:RADio:WCDMa:TGPP:ARB:IQ:MODulation:ATTen:AUTO?
```

This command enables or disables the I/Q attenuation auto mode.

ON (1) This choice enables the attenuation auto mode which optimizes the modulator attenuation for the current conditions.

OFF (0) This choice holds the attenuator at its current setting or at a selected value. Refer to “[:IQ:MODulation:ATTen](#)” on page 350 for setting the attenuation value.

***RST** 1

Key Entry **Modulator Atten Manual Auto**

:IQ:MODulation:FILTer

Supported E4438C with Option 400

```
[:SOURCE]:RADio:WCDMa:TGPP:ARB:IQ:MODulation:FILTer 2.1e6|40e6|THROUGH
[:SOURCE]:RADio:WCDMa:TGPP:ARB:IQ:MODulation:FILTer?
```

This command enables you to select a filter or through path for I/Q signals modulated onto the RF carrier. Selecting a filter using this command will automatically set “[:IQ:MODulation:FILTer:AUTO](#)” on page 351 to OFF(0) mode.

2.1E6 This choice applies a 2.1 MHz baseband filter to the I/Q signals.

40E6 This choice applies a 40 MHz baseband filter to the I/Q signals.

Wideband CDMA ARB Subsystem–Option 400 (:SOURce):RADio:WCDMa:TGPP:ARB)

THRough	This choice bypasses filtering.
*RST	THR
Key Entry	2.100 MHz 40.000 MHz Through

:IQ:MODulation:FILTer:AUTO

Supported E4438C with Option 400

```
[ :SOURce ] :RADio:WCDMa:TGPP:ARB:IQ:MODulation:FILTer:AUTO ON|OFF|1|0
[ :SOURce ] :RADio:WCDMa:TGPP:ARB:IQ:MODulation:FILTer:AUTO?
```

This command enables or disables the automatic selection of the filters for I/Q signals modulated onto the RF carrier.

ON(1)	This choice will automatically select a digital modulation filter.
OFF(0)	This choice disables the auto feature which lets you select a digital modulation filter or through path. Refer to “ :IQ:MODulation:FILTer ” on page 350 for selecting a filter or through path.

*RST 1

Key Entry **I/Q Mod Filter Manual Auto**

:LINK

Supported E4438C with Option 400

```
[ :SOURce ] :RADio:WCDMa:TGPP:ARB:LINK DOWN|UP
[ :SOURce ] :RADio:WCDMa:TGPP:ARB:LINK?
```

This command selects either a downlink or uplink channel configuration.

*RST DOWN

Key Entry **Link Down Up**

:LINK:DOWN:OACP

Supported E4438C with Option 400

```
[ :SOURce ] :RADio:WCDMa:TGPP:ARB:LINK:DOWN:OACP ADJ|ALT
[ :SOURce ] :RADio:WCDMa:TGPP:ARB:LINK:DOWN:OACP?
```

This command selects the channel power optimization type for any downlink channel W-CDMA setup.

ADJ This choice optimizes for adjacent channel power.

Wideband CDMA ARB Subsystem–Option 400 ([:SOURCE]:RADio:WCDMa:TGPP:ARB)

ALT	This choice optimizes for alternate channel power.
*RST	ADJ
Key Entry	Optimize ACP ADJ ALT
Remarks	This command is operational for any downlink channel W-CDMA setup. To change the current W-CDMA setup information, refer to “:LINK:DOWN:SETup” on page 352.

:LINK:DOWN:SETup

Supported E4438C with Option 400

```
[:SOURCE]:RADio:WCDMa:TGPP:ARB:LINK:DOWN:SETup DPCH1 | DPCH3 | PPSCH |
PPDPCH1 | PPDPCH3 | TM1D16 | TM1D32 | TM1D64 | TM2 | TM3D16 | TM3D32 | TM4 | TM5H2 | TM5H4 |
TM5H8 | MCARrier | "<file name>"
[:SOURCE]:RADio:WCDMa:TGPP:ARB:LINK:DOWN:SETup?
```

This command selects a predefined channel setup or multicarrier, and turns multicarrier off or on (see the MCARrier choice description).

DPCH1	This choice selects 1 dedicated physical channel.
DPCH3	This choice selects 3 dedicated physical channels.
PPSCH	This choice selects a primary command control physical channel (PCCPCH) with a synchronization channel (SCH).
PPDPCH1	This choice selects a primary command control physical channel (PCCPCH) with a dedicated physical channel (DPCH).
PPDPCH3	This choice selects a primary command control physical channel (PCCPCH) with 3 dedicated physical channels.
TM1D16	This choice selects a Test Model 1 with 16 dedicated physical channels.
TM1D32	This choice selects a Test Model 1 with 32 dedicated physical channels.
TM1D64	This choice selects a Test Model 1 with 64 dedicated physical channels.
TM2	This choice selects a Test Model 2 downlink W-CDMA setup.
TM3D16	This choice selects a Test Model 3 with 16 dedicated physical channels.
TM3D32	This choice selects a Test Model 3 with 32 dedicated physical channels.
TM4	This choice selects a Test Model 4 downlink W-CDMA setup.
TM5H2	This choice selects a Test Model 5 with 6 DPCH and 2 HS-PDSCH (high speed physical shared channel) channels downlink W-CDMA setup.

Wideband CDMA ARB Subsystem–Option 400 ([:SOURCE]:RADio:WCDMa:TGPP:ARB)

TM5H4	This choice selects a Test Model 5 with 14 DPCH and 4 HS-PDSCH (high speed-physical downlink shared channel) channels downlink W-CDMA setup.		
TM5H8	This choice selects a Test Model 5 with 30 DPCH and 8 HS-PDSCH (high speed physical shared channel) channels downlink WCDMA setup.		
MCARrier	This choice selects multicarrier and turns it on. Selecting any other setup such as DPCH1 or TM1D16 turns multicarrier off. To select the multicarrier setup, see “:LINK:DOWN:SETup:MCARrier”.		
"<file name>"	This choice selects a user-defined channel setup file. Refer to “File Name Variables” on page 13 for information on the file name syntax.		
*RST	DPCH1		
Key Entry	1	3DPCH	PCCPCH + PCCPCH + SCH + 1 DPCH
	DPCH		SCH
	PCCPCH + SCH + 3	Test Model 1 w/ 16 DPCH	
	DPCH		
	Test Model 1 w/ 32	Test Model 1 w/ 64 DPCH	Test Model 2
	DPCH		
	Test Model 3 w/ 16 DPCH	Test Model 3 w/ 32 DPCH	Test Model 4
	Test Model 5	Test Model 5 w/4HSPDSCH	
	w/2HSPDSCH		
	Test Model 5 w/	Multicarrier Off	Custom W-CDMA
	8HSPDPCH	On	State

:LINK:DOWN:SETup:MCARrier

Supported E4438C with Option 400

```
[:SOURCE]:RADio:WCDMa:TGPP:ARB:LINK:DOWN:SETup:MCARrier CAR2|CAR3|CAR4|
CAR4TM1D64|"<file name>"
```

```
[:SOURCE]:RADio:WCDMa:TGPP:ARB:LINK:DOWN:SETup:MCARrier?
```

This command defines the type of multicarrier W-CDMA setup.

CAR2 a standard 2-carrier setup with the following settings:

Carrier 1: PCCPCH + SCH, –7.5 MHz frequency offset, 0 dB power

Carrier 2: PCCPCH + SCH, 7.5 MHz frequency offset, 0 dB power

CAR3 a standard 3-carrier setup with the following settings:

Carrier 1: PCCPCH + SCH, –5 MHz frequency offset, 0 dB power

Wideband CDMA ARB Subsystem–Option 400 ([:SOURCE]:RADio:WCDMa:TGPP:ARB)

Carrier 2: PCCPCH + SCH, 0 kHz frequency offset, 0 dB power

Carrier 3: PCCPCH + SCH, 5 MHz frequency offset, 0 dB power

Wideband CDMA ARB Subsystem–Option 400 (:SOURce):RADio:WCDMa:TGPP:ARB)

CAR4	a standard 4-carrier setup with the following settings: Carrier 1: PCCPCH + SCH, –7.5 MHz frequency offset, 0 dB power Carrier 2: PCCPCH + SCH, –2.5 MHz frequency offset, 0 dB power Carrier 3: PCCPCH + SCH, 2.5 MHz frequency offset, 0 dB power Carrier 4: PCCPCH + SCH, 7.5 MHz frequency offset, 0 dB power
CAR4TM1D64	a standard 4-carrier test model 1 with 64 dedicated physical channels setup with the following settings: Carrier 1: Test Model 1 w/64 DPCH, –7.5 MHz frequency offset, 0 dB power Carrier 2: Test Model 1 w/64 DPCH, –2.5 MHz frequency offset, 0 dB power Carrier 3: Test Model 1 w/64 DPCH, 2.5 MHz frequency offset, 0 dB power Carrier 4: Test Model 1 w/64 DPCH, 7.5 MHz frequency offset, 0 dB power
*RST	CAR2
Key Entry	2 Carriers 3 Carriers 4 Carriers
Remarks	Refer to “ File Name Variables ” on page 13 for information on the file name syntax.

:LINK:DOWN:SETup:MCARrier:CLIPping:I

Supported	E4438C with Option 400
	[:SOURce] :RADio:WCDMa:TGPP:ARB:LINK:DOWN:SETup:MCARrier:CLIPping:I <val> [:SOURce] :RADio:WCDMa:TGPP:ARB:LINK:DOWN:SETup:MCARrier:CLIPping:I?
	This command limits the modulation level of the waveform’s I component to a percentage of full scale.
	The variable <val> is expressed in units of percent.
*RST	+1.00000000E+002
Range	10–100
Key Entry	Clip I To

:LINK:DOWN:SETup:MCARrier:CLIPping:Q**Supported** E4438C with Option 400

[:SOURCE]:RADio:WCDMa:TGPP:ARB:LINK:DOWN:SETup:MCARrier:CLIPping:Q <val>

[:SOURCE]:RADio:WCDMa:TGPP:ARB:LINK:DOWN:SETup:MCARrier:CLIPping:Q?

This command limits the modulation level of the waveform's Q component to a percentage of full scale.

The variable <val> is expressed in units of percent.

RST** +1.00000000E+002**Range** 10–100**Key Entry** Clip |Q| To**:LINK:DOWN:SETup:MCARrier:CLIPping:TYPE*Supported** E4438C with Option 400

[:SOURCE]:RADio:WCDMa:TGPP:ARB:LINK:DOWN:SETup:MCARrier:CLIPping:

TYPE IJQ|IORQ

[:SOURCE]:RADio:WCDMa:TGPP:ARB:LINK:DOWN:SETup:MCARrier:CLIPping:TYPE?

This command selects either IJQ or IORQ as the clipping type.

IJQ The combined I and Q waveform will be clipped (*circular* clipping).

IORQ The I and Q components of the waveform are clipped independently (*rectangular* clipping). I and Q can be clipped to different levels using this mode.

RST** IJQ**Key Entry** Clipping Type |I+jQ| |I|,|Q|**:LINK:DOWN:SETup:MCARrier:CLIPping[:IJQ]*Supported** E4438C with Option 400

[:SOURCE]:RADio:WCDMa:TGPP:ARB:LINK:DOWN:SETup:MCARrier:

CLIPping[:IJQ] <val>

[:SOURCE]:RADio:WCDMa:TGPP:ARB:LINK:DOWN:SETup:MCARrier:CLIPping[:IJQ]?

This command clips (limits) the modulation level of the combined I and Q waveform to a percentage of full scale.

The variable <val> is expressed in units of percent.

***RST** +1.00000000E+002

Wideband CDMA ARB Subsystem–Option 400 (:SOURce):RADio:WCDMa:TGPP:ARB)

Range	10–100
Key Entry	Clip I+jQ To

:LINK:DOWN:SETup:MCARrier:SCODE:AINCrement

Supported E4438C with Option 400

[:SOURce] :RADio:WCDMa:TGPP:ARB:LINK:DOWN:SETup:MCARrier:SCODE:AINCrement

This command will sort carriers by frequency offset and auto-increment scramble codes starting from the current scramble code value for the lowest frequency carrier.

Key Entry **Increment Scramble Code**

Remarks If the lowest frequency carrier has a scramble code value of N/A, the auto-increment value will start at 0.

:LINK:DOWN:SETup:MCARrier:STORe

Supported E4438C with Option 400

[:SOURce] :RADio:WCDMa:TGPP:ARB:LINK:DOWN:SETup:MCARrier:STORe "<file name>"

This command stores the current multicarrier setup information.

The stored file contains information including the digital modulation format, number of carriers, frequency spacing, and power settings for the multicarrier setup.

Key Entry **Store Custom Multicarrier**

Remarks User defined files created using firmware prior to C.02.40 did not save the setting for Increment Scramble Code, Increment Timing Offset, and Clipping Type settings. When loading user defined files created with firmware prior to C.02.40, Increment Scramble Code and Increment Timing Offset will default to Off and the Clipping Type settings will default to 100%. Firmware C.02.40 will save the Increment Scramble Code, Increment Timing Offset and Clipping Type settings.

Refer to [“File Name Variables” on page 13](#) for information on the file name syntax.

:LINK:DOWN:SETup:MCARrier:TABLE

Supported E4438C with Option 400

```
[:SOURCE]:RADio:WCDMa:TGPP:ARB:LINK:DOWN:SETup:MCARrier:TABLE INIT |
APPend | <carrier_num>, DPCH1 | DPCH3 | PPSCH | PPDPCCH1 | PPDPCCH3 | TM1D16 | TM1D32 |
TM1D64 | TM2 | TM3D16 | TM3D32 | TM4 | TM5H2 | TM5H4 | TM5H8 | "<filename>", <freq_offset
>, <power> [, <scramble code>, <timing offset>, <initial phase>,
<pre-FIR circular clipping> [<clipping units {pct} | dB>] ,
<post-FIR circularclipping> [<clipping units {pct} | dB>]]
[:SOURCE]:RADio:WCDMa:TGPP:ARB:LINK:DOWN:SETup:MCARrier:
TABLE? <carrier_num>
```

This command defines the multicarrier format and waveform.

Use INIT to clear the table and define the parameters for the first carrier; use APPend to add new channels. To edit an existing carrier, use its carrier number (<carrier_num>).

The variable <freq_offset> is expressed in units of Hertz (kHz–MHz).

The variable <power> is expressed in units of decibels (dB).

The carrier type, frequency offset, and power level are returned when a query is initiated. The output format is as follows:

```
<carrier type>, <freq_offset>, <power>
```

INIT	This choice clears the current information and creates a new one-row table, allowing for further definition using additional parameters.
APPend	This choice adds rows to an existing table. The maximum number of rows for one table is 16.
DPCH1	This choice selects 1 dedicated physical channel.
DPCH3	This choice selects 3 dedicated physical channels.
PPSCH	This choice selects a primary command control physical channel (PCCPCH) with a synchronization channel (SCH).
PPDPCH1	This choice selects a primary command control physical channel (PCCPCH) with a dedicated physical channel (DPCH).
PPDPCH3	This choice selects a primary command control physical channel (PCCPCH) with 3 dedicated physical channels.
TM1D16	This choice selects a test model 1 with 16 dedicated physical channels.
TM1D32	This choice selects a test model 1 with 32 dedicated physical channels.
TM1D64	This choice selects a test model 1 with 64 dedicated physical channels.

Wideband CDMA ARB Subsystem–Option 400 ([:SOURce]:RADio:WCDMa:TGPP:ARB)

TM2	This choice selects a test model 2.
TM3D16	This choice selects a test model 3 with 16 dedicated physical channels.
TM3D32	This choice selects a test model 3 with 32 dedicated physical channels.
TM4	This choice selects a test model 4.
TM5H2	This choice selects a Test Model 5 with 6 DPCH and 2 HS-PDSCH (high speed physical shared channel) channels downlink W-CDMA setup.
TM5H4	This choice selects a Test Model 5 with 14 DPCH and 4 HS-PDSCH (high speed-physical downlink shared channel) channels downlink W-CDMA setup.
TM5H8	This choice selects a Test Model 5 with 30 DPCH and 8 HS-PDSCH (high speed physical shared channel) channels downlink W-CDMA setup.
<scramble code>	This variable sets the scramble code value.
<timing offset>	This variable sets the timing offset value.
<initial phase>	This variable sets the initial phase value. The units are not specified but the value represents degrees.
<clipping>	This variable sets the clipping value. If the units are not specified, the value will default to percent.
<carrier_num>	This variable specifies the number of multicarriers.
*RST	<i>carrier type</i> : PPSCH <i><freq_offset></i> : +7.50000000E+006 <i><power></i> : +0.00000000E+000
Range	<i><freq_offset></i> : -37.5E6 to 37.5E6 <i><power></i> : -40 to 0 <i>scramble code</i> : 0–511 <i>timing offset</i> : 0–149 <i>initial phase</i> : 0–359 <i>clipping(in units of percent)</i> : 0.0–100.0 or 0.0 to -20.0 (if units are dB)
Key Entry	1 DPCH 3 DPCH PCCPCH + SCH PCCPCH + SCH + 1 DPCH PCCPCH + SCH + 3 DPCH Test Model 1 w/ 16 DPCH Test Model 1 w/ 32 DPCH Test Model 1 w/ 64 DPCH Test Model 2 Test Model 3 w/ 16 DPCH Test Model 3 w/ 32 DPCH Test Model 4 Test Model 5 w/2HSPDSCH Test Model 5 w/4HSPDSCH Test Model 5 w/8HSPDSCH
Remarks	Refer to “ File Name Variables ” on page 13 for information on the file name syntax. If the parameter set by this command is changed while the signal is active, the apply command must be executed for the change to occur. Refer to

“:LINK:DOWN:SETup:TABLE:APPLY” on page 361.

:LINK:DOWN:SETup:MCARrier:TABLE:NCARriers

Supported E4438C with Option 400

[:SOURCE] :RADio:WCDMa:TGPP:ARB:LINK:DOWN:SETup:MCARrier:TABLE:NCARriers?

This command queries the number of carriers specified for the W-CDMA multicarrier waveform.

***RST** +2

:LINK:DOWN:SETup:MCARrier:TOFFset:AINCrement

Supported E4438C with Option 400

[:SOURCE] :RADio:WCDMa:TGPP:ARB:LINK:DOWN:SETup:MCARrier:TOFFset:AINCrement

This command will sort carriers by frequency offset and auto-increment timing offsets. The new values will start with the current timing offset for the lowest frequency carrier and increment by one for each subsequent carrier.

Key Entry Increment Timing Offset

:LINK:DOWN:SETup:STORE

Supported E4438C with Option 400

[:SOURCE] :RADio:WCDMa:TGPP:ARB:LINK:DOWN:SETup:STORE "<file name>"

This command stores the current downlink setup information into the memory catalog with the entered file name.

Along with the contents of the W-CDMA channel table editor (channel types, Walsh code, power levels, PN offset, and data), this command stores the following information to the signal generator memory:

- FIR filter
- FIR filter file name
- FIR filter alpha
- FIR filter BbT
- FIR filter channel (EVM or ACP)
- I/Q mapping
- increment scramble code
- increment timing offset
- link
- spread type

Wideband CDMA ARB Subsystem–Option 400 ([:SOURce]:RADio:WCDMa:TGPP:ARB)

spread rate
 ARB reference clock source (internal or external)
 ARB reference clock frequency
 clipping
 multicarrier spacing
 radio configuration

Key Entry **Store Custom W-CDMA State**

Remarks Refer to “[File Name Variables](#)” on page 13 for information on the file name syntax.

:LINK:DOWN:SETup:TABLE:APPLY

Supported E4438C with Option 400

[:SOURce]:RADio:WCDMa:TGPP:ARB:LINK:DOWN:SETup:TABLE:APPLY

This command generates a W-CDMA signal based on the current values in the W-CDMA channel setup table editor.

Key Entry **Apply Channel Setup**

:LINK:DOWN:SETup:TABLE:CHANnel

Supported E4438C with Option 400

```
[:SOURce]:RADio:WCDMa:TGPP:ARB:LINK:DOWN:SETup:TABLE:CHANnel INIT |
APPend|<chan_num>,<chan_type>,<symbol_rate>,<spread_code>,<power>,<
timing_offset>,<TFCI>,<TPC>,<scramble_code>,STANdard|RALternate|
LALternate,<scramble_offset>,RANdOm|PN9|PINdicator|
<data_val>,<TFCI_power>,<TPC_power>,<pilot_power>,<pilot_bits>
[:SOURce]:RADio:WCDMa:TGPP:ARB:LINK:DOWN:SETup:TABLE:CHANnel? <chan_num>
```

This command sets up the W-CDMA downlink channel type parameters.

Use INIT to clear the table editor and define the parameters for the first channel; use APPend to add new channels. To edit an existing channel, use its channel number <chan_num>.

The <power>, <TFCI_power>, <TPC_power>, and <pilot_power> variables are expressed in units of decibels (dB).

The channel type, symbol rate, spread code, power, timing offset, TFCI value, TPC value, scramble code, scramble type, scramble offset, data type, TFCI power, TPC power, pilot power, and the number of pilot bits are returned when a query is initiated. The output format is as follows:

```
<chan_type>,<symbol_rate>,<spread_code>,<power>,<tDPCH_offset>,<TFCI>,<
TPC>,<scramble_code>,<scramble_type>,<scramble_code>,<scramble_offset>,<
```

Wideband CDMA ARB Subsystem–Option 400 ([:SOURCE]:RADio:WCDMa:TGPP:ARB)

- <data_type>, <TFCI_power>, <TPC_power>, <pilot_power>, <pilot_bits>
- INIT This choice clears the current information and creates a new one-row table, allowing for further definition using additional parameters.
- APPend This choice adds a row to an existing table.
- <chan_num> This variable sets the physical channel number.
- <chan_type> This variable sets the channel type.
- <timing_offset> This variable sets the symbol offset.
- <TFCI> This variable sets the transport format combination indicator.
- <TPC> This variable sets the transmit power control.
- STANdard This choice sets the scramble type to standard.
- RALternate This choice sets the scramble type to right alternate.
- LALternate This choice sets the scramble type to left alternate.
- RANDom This choice sets a randomly generated pseudo-random sequence pattern as output data.
- PN9 This choice sets an internally generated 9-bit pseudo-random sequence pattern as output data.
- PINDicator This choice sets the paging indicator channel (PICH).
- <data_val> This variable sets the data value.
- <TFCI_power> This variable sets the transport format combination indicator power offset.
- <TPC_power> This variable sets the transport power control power offset.
- <pilot_power> This variable sets the pilot power offset.
- <pilot_bits> This variable sets the number of pilot bits that will be in the dedicated physical channel (DPCH).

Table 5-1 Variables and Channel Types

	SSC H	CPIC H	PCCPC H	SCCPC H	PIC H	DPC H	OCN S	PSC H
Channel number	X	X	X	X	X	X	X	X
Symbol rate	N/A	N/A	N/A	X	N/A	X	X	N/A

Table 5-1 Variables and Channel Types

	SSC H	CPIC H	PCCPC H	SCCPC H	PIC H	DPC H	OCN S	PSC H
Spread code	N/A	X	X	X	X	X	X	N/A
Power	X	X	X	X	X	X	X	X
Symbol offset	N/A	N/A	N/A	N/A	X	X	N/A	N/A
TFCI	N/A	N/A	N/A	X	N/A	X	N/A	N/A
TPC	N/A	N/A	N/A	N/A	N/A	X	N/A	N/A
Scramble code	X	X	X	X	X	X	X	N/A
Standard	X	X	X	N/A	X	X	X	N/A
Right alternate	X	X	X	N/A	X	X	X	N/A
Left alternate	X	X	X	N/A	X	X	X	N/A
Scramble offset	X	X	X	X	X	X	X	N/A
Random	N/A	N/A	X	X	X	X	X	N/A
PN9	N/A	N/A	X	X	X	X	X	N/A
Paging Indicator	N/A	N/A	N/A	N/A	X	N/A	N/A	N/A
Data value	N/A	N/A	X	N/A	X	X	X	N/A
TFCI power	N/A	N/A	N/A	N/A	X	N/A	N/A	N/A
Pilot power offset	N/A	N/A	N/A	N/A	X	N/A	N/A	N/A
Pilot bits	N/A	N/A	N/A	X	X	N/A	N/A	N/A

Table 5-2 Variables and Channel Types

	HSPDSCH	HSSCCH
Channel number	X	X
Symbol rate	N/A (fixed to 30ksps)	N/A (fixed to 240ksps)

Table 5-2 Variables and Channel Types

	HSPDSCH	HSSCCH
Spread code	X	X
Power	X	X
Symbol offset	X	X
TFCI	N/A	N/A
TPC	N/A	N/A
Scramble code	X	X
Standard	X	X
Right alternate	X	X
Left alternate	X	X
Scramble offset	X	X
Random	X	X
PN9	X	X
Paging Indicator	N/A	N/A
Data value	X	X
TFCI power	N/A	N/A
Pilot power offset	N/A	N/A
Pilot bits	N/A	N/A

```
*RST <chan_type>: DPCH <symbol_rate>: +3.00000000E+004
<spread_code>: +8 <scramble_offset>: +0.00000000E+000
power: +0.00000000E+000 <tDPCH_offset>: +0 <TFCI>: +0
<TPC>: #H5555 <scramble_code>: +0 scramble type: STAN
<TFCI_power>: +0.00000000E+000
<TPC_power>: +0.00000000E+000 <pilot_power>: +0.00000000E+000
<pilot_bits>: +4
```

Wideband CDMA ARB Subsystem–Option 400 ([:SOURce]:RADio:WCDMa:TGPP:ARB)

Range <chan_type>: PSCH SSCH CPICH PCCPch SCCPch
 DPCH PICH OCNS HSSCch HSPDsch
 <power>: -40 to 0 <tDPCH_offset>: 0-149 <TFCI>: 0-1023
 <TPC>: 0000-7FFF <scramble_code>: 0-511
 <scramble_offset>: 0-15 <data_val>: 00000000-11111111
 <TFCI_power>: -20 to 20 <TPC_power>: -20 to 20
 <pilot_power>: 0000-7FFF <pilot_bits>: 0-511

SCCPCH Channel

<symbol_rate>	<spread_code>	*<pilot_bits>
15 ksps	0-256	0,8
30 ksps	0-128	0,8
60 ksps	0-64	0,8
120 ksps	0-32	0,8
240 ksps	0-16	0,16
480 ksps	0-8	0,16
960 ksps	0-4	0,16

All Other Channels

<symbol_rate>	<spread_code>	<pilot_bits>
7.5 ksps	0-511	4
15 ksps	0-255	2,4,8
30 ksps	0-127	4,8
60 ksps	0-63	8
120 ksps	0-31	8
240 ksps	0-15	16
480 ksps	0-7	16
960 ksps	0-3	16

Key Entry

Channel	Type	Symbol Rate	First Spread Code	Power
		TFCI	Field Off On	Scramble Code
		Scramble Offset		
Random	PN9	Standard	Left Alternate	Right Alternate
PCCPCH	SCCPCH	PSCH	SSCH	CPICH
	DPCH	PICH	OCNS	
	HSPDSCH	HSSCCH		

Field Entry

Spread Code	Power	Timing	TFCI	Scramble Code
		Offset		
TFCI	TPC	Pilot Power	Pilot Bits	Data
Power	Power			
Scramble	Scramble			
Type	Offset			

Wideband CDMA ARB Subsystem–Option 400 ([:SOURCE]:RADio:WCDMa:TGPP:ARB)

Remarks For additional information, refer to the 3GPP TS 25.211 (V 3.7) standard.
 If the parameter set by this command is changed while the signal is active, the apply command must be executed for the change to occur. Refer to “:LINK:DOWN:SETup:TABLE:APPLY” on page 361.

:LINK:DOWN:SETup:TABLE:NCHannels?

Supported E4438C with Option 400

[:SOURCE] :RADio:WCDMa:TGPP:ARB:LINK:DOWN:SETup:TABLE:NCHannel?

This command queries the number of channels being used for the carrier.

***RST** 1

:LINK:DOWN:SETup:TABLE:PADJust

Supported E4438C with Option 400

[:SOURCE] :RADio:WCDMa:TGPP:ARB:LINK:DOWN:SETup:TABLE:PADJust EQUAL|SCALE

This command sets the code domain power.

EQUAL This choice will adjust all channel powers to have equal energy per symbol, referenced to 7.5 ksps and increasing by 3 dB for each doubling of the symbol rate.

SCALE This choice will scale the channel power levels so that the sum of the powers are equal to 0 dB.

Key Entry **Equal Energy per Symbol** **Scale To 0dB**

Remarks This command is available in downlink only.

:LINK:DOWN:TFCI

Supported E4438C with Option 400

[:SOURCE] :RADio:WCDMa:TGPP:ARB:LINK:DOWN:TFCI ON|OFF|1|0

[:SOURCE] :RADio:WCDMa:TGPP:ARB:LINK:DOWN:TFCI?

This command enables or disables the transport format combination indicator (TFCI) field for all channels.

***RST** 1

Key Entry **TFCI Field Off On**

Wideband CDMA ARB Subsystem–Option 400 ([:SOURCE]:RADIO:WCDMA:TGPP:ARB)

:LINK:UP:OACP

Supported E4438C with Option 400

```
[:SOURCE]:RADIO:WCDMA:TGPP:ARB:LINK:UP:OACP ADJ|ALT
[:SOURCE]:RADIO:WCDMA:TGPP:ARB:LINK:UP:OACP?
```

This command selects the channel power optimization type for any uplink channel W-CDMA setup.

ADJ This choice optimizes for adjacent channel power.

ALT This choice optimizes for alternate channel power.

***RST** ADJ

Key Entry Optimize ACP ADJ ALT

Remarks This command is only operational for any uplink channel W-CDMA setup.

To change the current W-CDMA setup information, refer to “[:LINK:UP:SETup](#)” on page 368.

:LINK:UP:SCRAMBLE

Supported E4438C with Option 400

```
[:SOURCE]:RADIO:WCDMA:TGPP:ARB:LINK:UP:SCRAMBLE <val>
[:SOURCE]:RADIO:WCDMA:TGPP:ARB:LINK:UP:SCRAMBLE?
```

This command sets the scramble code for the uplink.

***RST** #H000000

Range #H0–FFFFFFF

Key Entry Scramble Code

:LINK:UP:SDPDch

Supported E4438C with Option 400

```
[:SOURCE]:RADIO:WCDMA:TGPP:ARB:LINK:UP:SDPDch I|Q
[:SOURCE]:RADIO:WCDMA:TGPP:ARB:LINK:UP:SDPDch?
```

This command selects whether the second dedicated physical data channel (SDPDCH) will be put onto I or Q.

***RST** Q

Key Entry Second DPDCH I Q

:LINK:UP:SETup

Supported E4438C with Option 400

```
[:SOURCE]:RADio:WCDMa:TGPP:ARB:LINK:UP:SETup DPCCH|DDPDCH1|DDPDCH2|
DDPDCH3|DDPDCH4|DDPDCH5|"<file name>"
```

```
[:SOURCE]:RADio:WCDMa:TGPP:ARB:LINK:UP:SETup?
```

This command selects a dedicated physical control channel (DPCCH) for uplink with the option to add one or more dedicated physical data channel (DPDCH) or a previously stored setup.

- DPCCH This choice selects 1 dedicated physical control channel.
- DDPDCH1 This choice selects 1 dedicated physical control channel and 1 dedicated physical data channel.
- DDPDCH2 This choice selects 1 dedicated physical control channel and 2 dedicated physical data channel.
- DDPDCH3 This choice selects 1 dedicated physical control channel and 3 dedicated physical data channel.
- DDPDCH4 This choice selects 1 dedicated physical control channel and 4 dedicated physical data channel.
- DDPDCH5 This choice selects 1 dedicated physical control channel and 5 dedicated physical data channel.

***RST** DPCCH

Key Entry **DPCCH DPCCH + 1 DPDCH DPCCH + 2 DPDCH DPCCH + 3 DPDCH
DPCCH + 4 DPDCH DPCCH + 5 DPDCH Custom WCDMA State**

Remarks Refer to “[File Name Variables](#)” on page 13 for information on the file name syntax.

If the parameter set by this command is changed while the signal is active, the apply command must be executed for the change to occur. Refer to “[:LINK:UP:SETup:TABLE:APPLY](#)” on page 369.

:LINK:UP:SETup:STORE

Supported E4438C with Option 400

```
[ :SOURCE ] :RADio:WCDMa:TGPP:ARB:LINK:UP:SETup:STORE "<file name>"
```

This command stores the current state into a designated file name.

Key Entry Store To File

Remarks You can recall a saved state from signal generator memory (non-volatile) by executing the following commands (using a designated file name):

For downlink, refer to “:LINK:DOWN:SETup” on page 352.

For uplink, refer to “:LINK:UP:SETup” on page 368.

Refer to “File Name Variables” on page 13 for information on the file name syntax.

:LINK:UP:SETup:TABLE:APPLY

Supported E4438C with Option 400

```
[ :SOURCE ] :RADio:WCDMa:TGPP:ARB:LINK:UP:SETup:TABLE:APPLY
```

This command applies the signal based on the current values in the W-CDMA channel setup table editor.

Key Entry Apply Channel Setup

Remarks Refer to “File Name Variables” on page 13 for information on the file name syntax.

:LINK:UP:SETup:TABLE:CHANnel

Supported E4438C with Option 400

```
[ :SOURCE ] :RADio:WCDMa:TGPP:ARB:LINK:UP:SETup:TABLE:CHANnel  
INIT|APPend|<chan_num>,<chan_type>,<symbol_rate>,<spread_code>,<power>,  
<TFCl>,<TCP>,RANDOM|<data_val>,<fbi_bits_count>,<fbi_bits_value>  
[ :SOURCE ] :RADio:WCDMa:TGPP:ARB:LINK:UP:SETup:TABLE:CHANnel? <chan_num>
```

This command defines the channel parameters of the signal.

Use INIT to clear the table editor and define the parameters for the first channel; use APPend to add new channels. To edit an existing channel, use its channel number <chan_num>.

The variable <power> is expressed in units of decibels (dB).

Wideband CDMA ARB Subsystem–Option 400 ([:SOURCE]:RADio:WCDMa:TGPP:ARB)

The channel type, symbol rate, spread code, power, TFCI value, TPC value, data value, FBI bit count, and FBI bit value are returned when a query is initiated. The output format is as follows:

<chan_type>, <symbol_rate>, <spread_code>, <power>, <TFCI>, <TCP>, <data_val>, <fbi_bits_count>, <fbi_bits_value>

INIT This choice clears the current information and creates a new one-row table, allowing for further definition using additional parameters.

APPend This choice adds a row to an existing table.

RANDom This choice selects random data format for the digital modulation signal.

<fbi_bits_count> This variable sets the number of feedback information (FBI) bits.

<fbi_bits_value> This variable sets the value of the FBI bits.

***RST** <chan_type>: DPCH <symbol_rate>: +1.50000000E+
 <spread_code>: +0 <power>: +0.00000000E+000 <TFCI>: +0
 <TPC>: #H5555 <data_val>: RAND <FBI Bits Count>: +0
 <FBI Bit Count>: +0

Range <power>: -40 to 0 <data_val>: 00000000–11111111
 <fbi_bits_count>: 0–2 <fbi_bits_value>: 0–3

<symbol_rate>	<spread_rate>
7.5 ksps	0–511
15 ksps	0–255
30 ksps	0–127
60 ksps	0–63
120 ksps	0–31
240 ksps	0–15
480 ksps	0–7
960 ksps	0–3

Key Entry Channel Type Symbol Rate First Spread Code Power
 Spread Code TFCI Field Off On Scramble Code Scramble Offset
Random

Remarks If the parameter set by this command is changed while the signal is active, the apply command must be executed for the change to occur. Refer to [“:LINK:UP:SETup:TABLE:APPLY” on page 369.](#)

:LINK:UP:SETup:TABLE:GUnit**Supported** E4438C with Option 400[:SOURCE]:RADIO:WCDMA:TGPP:ARB:LINK:UP:SETup:TABLE:GUnit DB|LINear|INDEX
[:SOURCE]:RADIO:WCDMA:TGPP:ARB:LINK:UP:SETup:TABLE:GUnit?

This command selects the uplink power measurement units.

DB The power is set in decibels-exponential.**LINear** The power is set to increase linearly.**INDEX** The power is set at an index level - steps.***RST** DB**Key Entry** Gain Unit dB Lin Index**Remarks** If the parameter set by this command is changed while the signal is active, the apply command must be executed for the change to occur. Refer to [“:LINK:UP:SETup:TABLE:APPLY” on page 369](#).**:LINK:UP:SETup:TABLE:NCHannel****Supported** E4438C with Option 400

[:SOURCE]:RADIO:WCDMA:TGPP:ARB:LINK:UP:SETup:TABLE:NCHannels?

This command queries the setup table for the number of uplink channels.

RST** 1**:LINK:UP:TFCI*Supported** E4438C with Option 400[:SOURCE]:RADIO:WCDMA:TGPP:ARB:LINK:UP:TFCI ON|OFF|1|0
[:SOURCE]:RADIO:WCDMA:TGPP:ARB:LINK:UP:TFCI?

This command enables or disables the transport format combination indicator (TFCI) field for all channels in the table.

***RST** 1**Key Entry** TCFI Field Off On

:MDEStination:AAMPlitude

Supported E4438C with Option 400

```
[ :SOURCE ] :RADio:WCDMa:TGPP:ARB:MDEStination:AAMPlitude NONE | M1 | M2 | M3 | M4  
[ :SOURCE ] :RADio:WCDMa:TGPP:ARB:MDEStination:AAMPlitude?
```

This command routes the selected marker to the Alternate Amplitude function. The NONE parameter clears the marker to the Alternate Amplitude function.

***RST** NONE

Key Entry None Marker 1 Marker 2 Marker 3 Marker 4

:MDEStination:ALCHold

Supported E4438C with Option 400

CAUTION Incorrect automatic level control (ALC) sampling can create a sudden unlevelled condition that may create a spike in the RF output potentially damaging a DUT or connected instrument. Ensure that you set markers to let the ALC sample over an amplitude that accounts for the high power levels within the signal.

```
[ :SOURCE ] :RADio:WCDMa:TGPP:ARB:MDEStination:ALCHold NONE | M1 | M2 | M3 | M4  
[ :SOURCE ] :RADio:WCDMa:TGPP:ARB:MDEStination:ALCHold?
```

This command enables or disables the marker ALC hold function for the selected marker. For setting markers, see “[:MARKer:[SET]]” on page 306.

Use the ALC hold function when you have a waveform signal that incorporates idle periods, or when the increased dynamic range encountered with RF blanking is not desired. The ALC leveling circuitry responds to the marker signal during the marker pulse (marker signal high), averaging the modulated signal level during this period.

The ALC hold function operates during the low periods of the marker signal. The marker polarity determines when the marker signal is high. For a positive polarity, this is during the marker points. For a negative polarity, this is when there are no marker points. For setting a marker’s polarity, see “[:MPOlarity:MARKer1|2|3|4]” on page 375.

NOTE Do not use the ALC hold for more than 100 ms, because it can affect the waveform’s output amplitude.

Wideband CDMA ARB Subsystem–Option 400 (:SOURce]:RADio:WCDMa:TGPP:ARB)

The marker signal has a minimum of a two-sample delay in its response relative to the waveform signal response. To compensate for the marker signal delay, offset marker points from the waveform sample point at which you want the ALC sampling to begin.

The ALC hold setting is part of the file header information, so saving the setting to the file header saves the current marker routing for the waveform file.

NOTE A waveform file that has unspecified settings in the file header uses the previous waveform's routing settings.

For more information on the marker ALC hold function, see the *E4428C/38C ESG Signal Generators User's Guide*. For setting the marker points, see “:MARKer:[SET]” on page 306.

NONE This terminates the marker ALC hold function.

M1–M4 These are the marker choices. The ALC hold feature uses only one marker at a time.

***RST** NONE

Example

```
:RAD:AWGB:ARB:MDES:ALCH M1
```

The preceding example routes marker 1 to the ALC Hold function.

Key Entry	None	Marker 1	Marker 2	Marker 3	Marker 4
-----------	------	----------	----------	----------	----------

Remarks	N/A				
---------	-----	--	--	--	--

:MDEStination:PULSe

Supported E4438C with Option 400

CAUTION The pulse function uses the ALC hold. Incorrect automatic level control (ALC) sampling can create a sudden unlevelled condition that may create a spike in the RF output potentially damaging a DUT or connected instrument. Ensure that you set markers to let the ALC sample over an amplitude that accounts for the high power levels within the signal.

```
[ :SOURce ] :RADio:WCDMa:TGPP:ARB:MDEStination:PULSe NONE | M1 | M2 | M3 | M4
[ :SOURce ] :RADio:WCDMa:TGPP:ARB:MDEStination:PULSe?
```

This command enables or disables the marker pulse/RF blanking function for the selected marker.

This function automatically uses the ALC hold function, so there is no need to select both the ALC hold and the pulse/RF blanking for the same marker.

NOTE Do not use ALC hold for more than 100 ms, because it can affect the waveform’s output amplitude.

The signal generator blanks the RF output when the marker signal goes low. The marker polarity determines when the marker signal is low. For a positive polarity, this is during the marker points. For a negative polarity, this is when there are no marker points. For setting a marker’s polarity, see “:MPOLarity:MARKer1|2|3|4” on page 375.

NOTE Set marker points prior to using this function. Enabling this function without setting marker points may create a continuous low or high marker signal, depending on the marker polarity. This causes either no RF output or a continuous RF output. See “:MARKer:[SET]” on page 306 for setting the marker points.

The marker signal has a minimum of a two-sample delay in its response relative to the waveform signal response. To compensate for the marker signal delay, offset marker points from the waveform sample point at which you want the RF blanking to begin. The RF blanking setting is part of the file header information, so saving the setting to the file header saves the current marker routing for the waveform file.

NOTE A waveform file that has unspecified settings in the file header uses the previous waveform’s routing settings. This could create the situation where there is no RF output signal, because the previous waveform used RF blanking.

For more information on the marker RF blanking function, see the *E4428C/38C ESG Signal Generators User’s Guide*.

NONE This terminates the marker RF blanking/pulse function.

M1–M4 These are the marker choices. The RF blanking/pulse feature uses only one marker at a time.

Example

```
:RAD:ARB:MDES:PULS M2
```

The preceding example routes marker 2 to Pulse/RF Blanking.

***RST** NONE

Key Entry None Marker 1 Marker 2 Marker 3 Marker 4

Wideband CDMA ARB Subsystem–Option 400 ([:SOURCE]:RADio:WCDMa:TGPP:ARB)

:MPOLarity:MARKer1|2|3|4

Supported E4438C with Option 400

```
[:SOURCE]:RADio:WCDMa:TGPP:ARB:MPOLarity:MARKer1|2|3|4 NEGative|POSitive
[:SOURCE]:RADio:WCDMa:TGPP:ARB:MPOLarity:MARKer1|2|3|4?
```

This command sets the polarity for the selected marker. For a positive marker polarity, the marker signal is high during the marker points. For a negative marker polarity, the marker signal is high during the period of no marker points.

***RST** POS

Key Entry	Marker 1 Polarity Neg Pos	Marker 2 Polarity Neg Pos	Marker 3 Polarity Neg Pos
	Marker 4 Polarity Neg Pos		

:REFerence:EXTernal:FREQuency

Supported E4438C with Option 400

```
[:SOURCE]:RADio:WCDMa:TGPP:ARB:REFerence:EXTernal:FREQuency <val>
[:SOURCE]:RADio:WCDMa:TGPP:ARB:REFerence:EXTernal:FREQuency?
```

This command sets the external reference frequency.

The variable <val> is expressed in hertz (Hz).

***RST** +1.00000000E+007

Range 2.5E5–1E8

Remarks The value specified by this command is effective only when you are using an external ARB reference applied to the BASEBAND GEN REF IN rear panel connector.

To specify external as the ARB reference source type, refer to [“:REFerence\[:SOURCE\]” on page 375](#).

:REFerence[:SOURCE]

Supported E4438C with Option 400

```
[:SOURCE]:RADio:WCDMa:TGPP:ARB:REFerence[:SOURCE] INTernal|EXTernal
[:SOURCE]:RADio:WCDMa:TGPP:ARB:REFerence[:SOURCE] ?
```

This command selects either an internal or external reference for the waveform clock.

***RST** 0

Wideband CDMA ARB Subsystem–Option 400 ([:SOURCE]:RADio:WCDMa:TGPP:ARB)

Key Entry	ARB Reference Ext Int
Remarks	If the EXTERNAL choice is selected, the external frequency value <i>must</i> be entered and the signal must be applied to the BASEBAND GEN REF IN rear panel connector. Refer to “[:REFERENCE:EXTERNAL:FREQUENCY]” on page 375 to enter the external reference frequency.

:RETRigger

Supported E4438C with Option 400

```
[ :SOURCE ] :RADio:WCDMa:TGPP:ARB:RETRigger ON|OFF|IMMediate  
[ :SOURCE ] :RADio:WCDMa:TGPP:ARB:RETRigger?
```

This command sets the retrigger mode.

ON	This choice specifies that if a trigger occurs while a waveform is initiated, the waveform will retrigger at the end of the previous waveform sequence and play once more.
OFF	This choice specifies that if a trigger occurs while a waveform is initiated, the action will be ignored.
IMMediate	This choice specifies that if a trigger occurs while a waveform is playing, the waveform will reset and replay from the start immediately upon receiving a trigger.

***RST** 0

Key Entry **Retrigger Mode Off On**

:REVision

Supported E4438C with Option 400

```
[ :SOURCE ] :RADio:WCDMa:TGPP:ARB:REVision?
```

This command checks the 3GPP supported standard for the arbitrary waveform generator firmware.

Wideband CDMA ARB Subsystem–Option 400 ([:SOURce]:RADio:WCDMa:TGPP:ARB)

:SCLock:RATE

Supported E4438C with Option 400

```
[:SOURce]:RADio:WCDMa:TGPP:ARB:SCLock:RATE <val>
```

```
[:SOURce]:RADio:WCDMa:TGPP:ARB:SCLock:RATE?
```

This command sets the sample clock rate for the W-CDMA modulation format.

The variable <val> is expressed in units of hertz.

***RST** +1.00000000E+008

Range 1–1E8

Key Entry ARB Sample Clock

Remarks The modulation format should be active before executing this command. If this command is executed before the modulation format is active, the entered value will be overridden by a calculated factory default value. Refer to “[:STATe]” on [page 383](#) to activate the modulation format.

:TRIGger:TYPE

Supported E4438C with Option 400

```
[:SOURce]:RADio:WCDMa:TGPP:ARB:TRIGger:TYPE CONTinuous|SINGLE|GATE
```

```
[:SOURce]:RADio:WCDMa:TGPP:ARB:TRIGger:TYPE?
```

This command sets the trigger mode (type) that controls the waveform’s playback.

Triggers control the playback by telling the ESG when to play the modulating signal (waveform). Depending on the trigger settings for the ESG, the waveform playback can occur once, continuously, or the ESG may start and stop playing the waveform repeatedly (GATE mode).

A trigger signal comprises both positive and negative signal transitions (states), which are also called high and low periods. You can configure the ESG to trigger on either state of the trigger signal. It is common to have multiple triggers, also referred to as trigger occurrences or events, occur when the signal generator requires only a single trigger. In this situation, the ESG recognizes the first trigger and ignores the rest.

When you select a trigger mode, you may lose the signal (carrier plus modulating) from the RF output until you trigger the waveform. This is because the ESG sets the I and Q signals to zero volts prior to the first trigger event, which suppresses the carrier. After the first trigger event, the waveform’s final I and Q levels determine whether you will see the carrier signal or not (zero = no carrier, other values = carrier visible). At the end of most files, the final I and Q points are set to a value other than zero.

There are four parts to configuring the trigger:

- Choosing the trigger type, which controls the waveform’s transmission.
- Setting the waveform’s response to triggers:
 - CONTInuous, see “:TRIGger:TYPE:CONTInuous[:TYPE]” on page 379
 - SINGle, see “:RETRigger” on page 376
 - GATE, selecting the mode also sets the response
- Selecting the trigger source (see “:TRIGger[:SOURce]” on page 380), which determines how the ESG receives its trigger signal, internally or externally. The GATE choice requires an external trigger.
- Setting the trigger polarity when using an external source:
 - CONTInuous and SINGle see “:TRIGger[:SOURce]:EXTernal:SLOPe” on page 382
 - GATE, see “:TRIGger:TYPE:GATE:ACTive” on page 379

For more information on triggering, see the *E4428C/38C ESG Signal Generators User’s Guide*.

The following list describes the trigger type command choices:

CONTInuous	Upon triggering, the waveform repeats continuously.
SINGle	Upon triggering, the waveform segment or sequence plays once.
GATE	An external trigger signal repeatedly starts and stops the waveform’s playback (transmission). The time duration for playback depends on the duty period of the trigger signal and the gate polarity selection (see “:TRIGger:TYPE:GATE:ACTive” on page 379). The waveform plays during the inactive state and stops during the active polarity selection state. The active state can be set high or low. The gate mode works only with an external trigger source.

NOTE The ARB gating behavior described above is opposite to the gating behavior for real-time custom mode.

*RST	CONT		
Key Entry	Continuous	Single	Gated

:TRIGger:TYPE:CONTInuous[:TYPE]

Supported E4438C with Option 400

```
[ :SOURce ] :RADio:WCDMa:TGPP:ARB:TRIGger:CONTInuous [ :TYPE ] FREE |
TRIGger | RESet
[ :SOURce ] :RADio:WCDMa:TGPP:ARB:TRIGger:CONTInuous [ :TYPE ] ?
```

This commands selects the waveform's response to a trigger signal while using the continuous trigger mode.

For more information on triggering and to select the continuous trigger mode, see “[:TRIGger:TYPE](#)” on page 377.

The following list describes the waveform's response to each of the command choices:

FREE	Turning the ARB format on immediately triggers the waveform. The waveform repeats until you turn the format off, select another trigger, or choose another waveform file.
TRIGger	The waveform waits for a trigger before play begins. When the waveform receives the trigger, it plays continuously until you turn the format off, select another trigger, or choose another waveform file.
RESet	The waveform waits for a trigger before play begins. When the waveform receives the trigger, it plays continuously. Subsequent triggers reset the waveform to the beginning. For a waveform sequence, this means to the beginning of the first segment in the sequence.
*RST	FREE
Key Entry	Free Run Trigger & Run Reset & Run

:TRIGger:TYPE:GATE:ACTive

Supported E4438C with Option 400

```
[ :SOURce ] :RADio:WCDMa:TGPP:ARB:TRIGger:TYPE:GATE:ACTive LOW | HIGH
[ :SOURce ] :RADio:WCDMa:TGPP:ARB:TRIGger:TYPE:GATE:ACTive?
```

This command selects the active state (gate polarity) of the gate while using the gating trigger mode.

The LOW and HIGH selections correspond to the low and high states of an external trigger signal. For example, when you select HIGH, the active state occurs during the high of the trigger signal. When the active state occurs, the ESG stops the waveform playback at the last played sample point, then restarts the playback at the next sample point when the inactive state occurs. For more information on triggering and to select gating as the trigger mode, see “[:TRIGger:TYPE](#)” on page 377.

The following list describes the ESG's gating behavior for the polarity selections:

Wideband CDMA ARB Subsystem—Option 400 (:SOURce):RADio:WCDMa:TGPP:ARB)

LOW	The waveform playback stops when the trigger signal goes low (active state) and restarts when the trigger signal goes high (inactive state).
HIGH	The waveform playback stops when the trigger signal goes high (active state) and restarts when the trigger signal goes low (inactive state).
*RST	HIGH
Key Entry	Gate Active Low High

:TRIGger[:SOURce]

Supported E4438C with Option 400

```
[ :SOURce ] :RADio:WCDMa:TGPP:ARB:TRIGger [ :SOURce ] KEY | EXT | BUS
[ :SOURce ] :RADio:WCDMa:TGPP:ARB:TRIGger [ :SOURce ] ?
```

This command sets the trigger source.

For more information on triggering, see “[:TRIGger:TYPE](#)” on page 377. The following list describes the command choices:

- | | |
|-----|--|
| KEY | This choice enables manual triggering by pressing the front-panel Trigger hardkey. |
| EXT | An externally applied signal triggers the waveform. This is the only choice that works with gating. The following conditions affect an external trigger: <ul style="list-style-type: none"> • The input connector selected for the trigger signal. You have a choice between the rear-panel PATTERN TRIG IN connector or the PATT TRIG IN 2 pin on the rear-panel AUXILIARY I/O connector. To make the connector selection, see “:TRIGger[:SOURce]:EXTErnal[:SOURce]” on page 382.

For more information on the connectors and on connecting the cables, see the <i>E4428C/38C ESG Signal Generators User’s Guide</i>. • The trigger signal polarity: <ul style="list-style-type: none"> — gating mode, see “:TRIGger:TYPE:GATE:ACTive” on page 379 — continuous and single modes, see “:TRIGger[:SOURce]:EXTErnal:SLOPe” on page 382 • The time delay between when the ESG receives a trigger and when the waveform responds to the trigger. There are two parts to setting the delay: <ul style="list-style-type: none"> — setting the amount of delay, see “:TRIGger[:SOURce]:EXTErnal:DELAy” on page 381 — turning the delay on, see “:TRIGger[:SOURce]:EXTErnal:DELAy:STATe” on page 381 |

Wideband CDMA ARB Subsystem–Option 400 (:SOURce):RADio:WCDMa:TGPP:ARB)

BUS This choice enables triggering over the GPIB or LAN using the *TRG or GET commands or the AUXILIARY INTERFACE (RS-232) using the *TRG command.

Key Entry **Trigger Key** **Bus** **Ext**

:TRIGger[:SOURce]:EXTErnal:DELay

Supported E4438C with Option 400

```
[ :SOURce ] :RADio:WCDMa:TGPP:ARB:TRIGger [ :SOURce ] :EXTErnal:DELay <val>
[ :SOURce ] :RADio:WCDMa:TGPP:ARB:TRIGger [ :SOURce ] :EXTErnal:DELay?
```

This command sets the amount of time to delay the ESG's response to an external trigger.

The delay is a path (time) delay between when the ESG receives the trigger and when it responds to the trigger. For example, configuring a trigger delay of two seconds, causes the ESG to wait two seconds after receipt of the trigger before the ESG plays the waveform.

The delay does not occur until you turn it on (see “:TRIGger[:SOURce]:EXTErnal:DELay:STATe” on page 381). You can set the delay value either before or after turning it on.

For more information on configuring an external trigger source and to select external as the trigger source, see “:TRIGger[:SOURce]” on page 380.

The unit of measurement for the variable <val> is in seconds (nsec–sec).

***RST** +1.00000000E–003

Range 1E–8 to 4E1

Key Entry **Ext Delay Time**

Remarks This command is effective only if an external trigger is selected as the trigger source. Refer to “:TRIGger[:SOURce]” on page 380.

:TRIGger[:SOURce]:EXTErnal:DELay:STATe

Supported E4438C with Option 400

```
[ :SOURce ] :RADio:WCDMa:TGPP:ARB:TRIGger [ :SOURce ] :EXTErnal:DELay:
STATe ON|OFF|1|0
[ :SOURce ] :RADio:WCDMa:TGPP:ARB:TRIGger [ :SOURce ] :EXTErnal:DELay:STATe?
```

This command enables or disables the arbitrary waveform generator's external trigger delay.

Wideband CDMA ARB Subsystem–Option 400 ([:SOURCE]:RADio:WCDMa:TGPP:ARB)

For setting the delay time, see “:TRIGger[:SOURCE]:EXTernal:DELay” on page 381, and for more information on configuring an external source, see “:TRIGger[:SOURCE]” on page 380.

***RST** 0

Key Entry **Ext Delay Off On**

:TRIGger[:SOURCE]:EXTernal:SLOPe

Supported E4438C with Option 400

[:SOURCE]:RADio:WCDMa:TGPP:ARB:TRIGger[:SOURCE]:EXTernal:
SLOPe POSitive|NEGative

[:SOURCE]:RADio:WCDMa:TGPP:ARB:TRIGger[:SOURCE]:EXTernal:SLOPe?

This command sets the polarity for an external trigger signal while using the continuous, single triggering mode. To set the polarity for gating, see “:TRIGger:TYPE:GATE:ACTive” on page 379.

The POSitive and NEGative selections correspond to the high (positive) and low (negative) states of the external trigger signal. For example, when you select POSitive, the waveform responds (plays) during the high state of the trigger signal. When the ESG receives multiple trigger occurrences when only one is required, the signal generator uses the first trigger and ignores the rest.

For more information on configuring an external trigger source and to select external as the trigger source, see “:TRIGger[:SOURCE]” on page 380.

***RST** NEG

Key Entry **Ext Polarity Neg Pos**

:TRIGger[:SOURCE]:EXTernal[:SOURCE]

Supported E4438C with Option 400

[:SOURCE]:RADio:WCDMa:TGPP:ARB:TRIGger[:SOURCE]:EXTernal

[:SOURCE] EPT1|EPT2|EPTRIGGER1|EPTRIGGER2

[:SOURCE]:RADio:WCDMa:TGPP:ARB:TRIGger[:SOURCE]:EXTernal[:SOURCE]?

This command selects which PATTERN TRIG IN connection the ESG uses to accept an externally applied trigger signal when external is the trigger source selection.

For more information on configuring an external trigger source and to select external as the trigger source, see “:TRIGger[:SOURCE]” on page 380. For more information on the rear-panel connectors, see the *E4428C/38C ESG Signal Generators User’s Guide*.

Wideband CDMA ARB Subsystem–Option 400 ([:SOURce]:RADio:WCDMa:TGPP:ARB)

The following list describes the command choices:

EPT1	This choice is synonymous with EPTRIGGER1 and selects the PATTERN TRIG IN rear-panel connector.
EPT2	This choice is synonymous with EPTRIGGER2 and selects the PATT TRIG IN 2 pin on the rear-panel AUXILIARY I/O connector.
EPTRIGGER1	This choice is synonymous with EPT1 and selects the PATTERN TRIG IN rear-panel connector.
EPTRIGGER2	This choice is synonymous with EPT2 and selects the PATT TRIG IN 2 pin on the rear-panel AUXILIARY I/O connector.
*RST	EPT1
Choices	EPT1 EPT2 EPTRIGGER1 EPTRIGGER2

[:STATe]

Supported E4438C with Option 400

```
[:SOURce]:RADio:WCDMa:TGPP:ARB[:STATe] ON|OFF|1|0
[:SOURce]:RADio:WCDMa:TGPP:ARB[:STATe]?
```

This command enables or disables the W-CDMA modulation format.

ON (1)	This choice enables the W-CDMA modulation capability and sets up the internal hardware to generate the currently selected W-CDMA signal selection.
OFF (0)	This choice disables the W-CDMA baseband signal capability.
*RST	0
Key Entry	W-CDMA Off On
Remarks	This choice also activates the I/Q state and sets the I/Q source to internal.

Symbols

ΦM Dev, [197](#)
 ΦM Dev Couple Off On, [197](#)
 FM ΦM Normal High BW, [192](#)
 ΦM Off On, [196](#)
 ΦM Path 1 2, [191](#)
 ΦM Stop Rate, [194](#)
 ΦM Sweep Time, [195](#)
 ΦM Tone 2 Ampl Percent of Peak, [194](#)
 # of Blocks field, [1079](#)
 # of Carriers softkey, [283](#), [285](#)
 # Points softkey, [57](#)
 # Skipped Points softkey, [306](#)

Numerics

0.7V,1.4V,1.65V,2.5V softkey, [427](#)
 1 DPCH softkey, [352](#), [358](#)
 1.23 MHz softkey, [263](#)
 1.25 MHz softkey, [263](#)
 1/2 Conv softkey, [1076](#), [1078](#), [1172](#)
 1/3 Conv softkey, [1076](#), [1078](#), [1172](#)
 10 msec softkey, [1105](#)
 1048576 softkey, [212](#)
 10ms Frame Pulse (DRPS11) softkey, [1058](#), [1060](#),
 [1061](#), [1062](#), [1063](#)
 10ms Frame Pulse (RPS6) softkey
 See wideband CDMA base band generator
 subsystem keys and fields
 12.2 kbps (34.121) softkey, [1041](#)
 128QAM softkey
 See custom subsystem keys
 See DECT subsystem keys
 See Dmodulation subsystem keys
 See EDGE subsystem keys
 See GSM subsystem keys
 See NADC subsystem keys
 See PDC subsystem keys
 See PHS subsystem keys
 See TETRA subsystem keys
 131072 softkey, [212](#)
 144 kbps (34.121) softkey, [1041](#)
 16 1's & 16 0's softkey
 See custom subsystem keys
 See DECT subsystem keys

See EDGE subsystem keys
See GSM subsystem keys
See NADC subsystem keys
See PDC subsystem keys
See PHS subsystem keys
See TETRA subsystem keys
 16384 softkey, [212](#)
 16-Lvl FSK softkey
 See DECT subsystem keys
 See PHS subsystem keys
 16PSK softkey
 See custom subsystem keys
 See DECT subsystem keys
 See Dmodulation subsystem keys
 See EDGE subsystem keys
 See GSM subsystem keys
 See NADC subsystem keys
 See PDC subsystem keys
 See PHS subsystem keys
 See TETRA subsystem keys
 16QAM softkey
 See custom subsystem keys
 See DECT subsystem keys
 See Dmodulation subsystem keys
 See EDGE subsystem keys
 See GSM subsystem keys
 See NADC subsystem keys
 See PDC subsystem keys
 See PHS subsystem keys
 See TETRA subsystem keys
 2 Carriers softkey, [353](#)
 2 SR3 Carriers softkey, [248](#)
 2.100 MHz softkey, [32](#), [208](#), [222](#), [246](#), [275](#), [303](#),
 [333](#), [350](#), [479](#)
 20 msec softkey, [1105](#)
 2560 msec softkey, [1105](#)
 256QAM softkey
 See custom subsystem keys
 See DECT subsystem keys
 See Dmodulation subsystem keys
 See EDGE subsystem keys
 See GSM subsystem keys
 See NADC subsystem keys
 See PDC subsystem keys
 See PHS subsystem keys

Index

- See* TETRA subsystem keys
 - 262144 softkey, [212](#)
 - 2-Lvl FSK softkey
 - See* custom subsystem keys
 - See* DECT subsystem keys
 - See* Dmodulation subsystem keys
 - See* EDGE subsystem keys
 - See* GSM subsystem keys
 - See* NADC subsystem keys
 - See* PDC subsystem keys
 - See* PHS subsystem keys
 - See* TETRA subsystem keys
 - 2nd Scr Offset field, [1042](#), [1049](#)
 - 3 Carriers softkey, [230](#), [248](#), [353](#)
 - 3 DPCH softkey, [352](#), [358](#)
 - 3.84MHz chip-clk (DRPS4) softkey, [1058](#), [1060](#), [1061](#), [1062](#), [1063](#)
 - 32 1's & 32 0's softkey
 - See* custom subsystem keys
 - See* DECT subsystem keys
 - See* EDGE subsystem keys
 - See* GSM subsystem keys
 - See* NADC subsystem keys
 - See* PDC subsystem keys
 - See* PHS subsystem keys
 - See* TETRA subsystem keys
 - 32 Ch Fwd softkey, [228](#), [231](#)
 - 32768 softkey, [212](#)
 - 32QAM softkey
 - See* custom subsystem keys
 - See* DECT subsystem keys
 - See* Dmodulation subsystem keys
 - See* EDGE subsystem keys
 - See* GSM subsystem keys
 - See* NADC subsystem keys
 - See* PDC subsystem keys
 - See* PHS subsystem keys
 - See* TETRA subsystem keys
 - 384 kbps (34.121) softkey, [1041](#)
 - 3GPP W-CDMA HSPA SCPI commands, [674](#)
 - 4 1's & 4 0's softkey
 - See* custom subsystem keys
 - See* DECT subsystem keys
 - See* EDGE subsystem keys
 - See* GSM subsystem keys
 - See* NADC subsystem keys
 - See* PDC subsystem keys
 - See* PHS subsystem keys
 - See* TETRA subsystem keys
- 4 Carriers softkey, [230](#), [248](#), [353](#)
 - 40 msec softkey, [1105](#)
 - 40.000 MHz softkey, [32](#), [205](#), [208](#), [217](#), [222](#), [241](#), [246](#), [270](#), [275](#), [302](#), [303](#), [331](#), [333](#), [348](#), [350](#), [472](#), [479](#)
 - 4-Lvl FSK softkey
 - See* custom subsystem keys
 - See* DECT subsystem keys
 - See* Dmodulation subsystem keys
 - See* EDGE subsystem keys
 - See* GSM subsystem keys
 - See* NADC subsystem keys
 - See* PDC subsystem keys
 - See* PHS subsystem keys
 - See* TETRA subsystem keys
 - 4QAM softkey
 - See* custom subsystem keys
 - See* DECT subsystem keys
 - See* Dmodulation subsystem keys
 - See* EDGE subsystem keys
 - See* GSM subsystem keys
 - See* NADC subsystem keys
 - See* PDC subsystem keys
 - See* PHS subsystem keys
 - See* TETRA subsystem keys
 - 5 Channel softkey, [254](#)
 - 524288 softkeys, [212](#)
 - 64 1's & 64 0's softkey
 - See* custom subsystem keys
 - See* DECT subsystem keys
 - See* EDGE subsystem keys
 - See* GSM subsystem keys
 - See* NADC subsystem keys
 - See* PDC subsystem keys
 - See* PHS subsystem keys
 - See* TETRA subsystem keys
 - 64 Ch Fwd softkey, [228](#), [231](#)
 - 64 kbps (34.121) softkey, [1041](#)
 - 64QAM softkey
 - See* custom subsystem keys
 - See* DECT subsystem keys

- See* Dmodulation subsystem keys
 - See* EDGE subsystem keys
 - See* GSM subsystem keys
 - See* NADC subsystem keys
 - See* PDC subsystem keys
 - See* PHS subsystem keys
 - See* TETRA subsystem keys
 - 65536 softkey, [212](#)
 - 8 1's & 8 0's softkey
 - See* custom subsystem keys
 - See* DECT subsystem keys
 - See* EDGE subsystem keys
 - See* GSM subsystem keys
 - See* NADC subsystem keys
 - See* PDC subsystem keys
 - See* PHS subsystem keys
 - See* TETRA subsystem keys
 - 8 Bit Pattern softkey, [471](#)
 - 8 Channel softkey, [254](#)
 - 80 msec softkey, [1105](#)
 - 80ms Frame Pulse (DRPS13) softkey, [1058](#), [1060](#), [1061](#), [1062](#), [1063](#)
 - 80ms Frame Pulse (RPS20) softkey
 - See* wideband CDMA base band generator subsystem keys and fields
 - 8648A/B/C/D softkey, [156](#), [159](#)
 - 8656B,8657A/B softkey, [156](#), [159](#)
 - 8657D NADC softkey, [156](#), [159](#)
 - 8657D PDC softkey, [156](#), [159](#)
 - 8657J PHS softkey, [156](#), [159](#)
 - 8-Lvl FSK softkey
 - See* DECT subsystem keys
 - See* PHS subsystem keys
 - 8PSK softkey
 - See* custom subsystem keys
 - See* DECT subsystem keys
 - See* Dmodulation subsystem keys
 - See* EDGE subsystem keys
 - See* GSM subsystem keys
 - See* NADC subsystem keys
 - See* PDC subsystem keys
 - See* PHS subsystem keys
 - See* TETRA subsystem keys
 - 9 Ch Fwd softkey, [228](#), [231](#)
 - 9 Channel softkey, [247](#)
- ## A
- A field softkey
 - See* DECT subsystem keys
 - A softkey, [1033](#)
 - abort list/step sweep, [166](#)
 - Access denied, [116](#)
 - Access softkey, [808](#)
 - ACS softkey, [1072](#)
 - Activate Secure Display softkey, [160](#)
 - Active softkey, [1069](#)
 - Actual BER softkey, [1181](#)
 - Actual BLER field, [1175](#), [1182](#)
 - Add Comment To Seq[n] Reg[nn] softkey, [123](#)
 - Adjust Gain softkey, [443](#)
 - Adjust Phase softkey, [47](#)
 - AICH softkey, [1139](#)
 - AICH Trigger Polarity Pos Neg softkey, [1114](#)
 - ALC
 - BW
 - 100 Hz, 1 kHz, 10 kHz, [58](#)
 - Auto, [58](#), [59](#)
 - Off,On, [58](#), [59](#)
 - ALC BW Normal Narrow, [22](#)
 - ALC BW Setting
 - Auto, [58](#), [59](#)
 - alc hold markers
 - awgn subsystem, [209](#)
 - cdma subsystem, [223](#)
 - cdma2000 arb subsystem, [257](#)
 - dmodulation subsystem, [276](#)
 - dual arb subsystem, [309](#)
 - multitone subsystem, [334](#), [335](#)
 - wideband CDMA ARB subsystem, [372](#)
 - wideband CDMA ARBsubsystem, [372](#)
 - ALC level, [60](#)
 - ALC Off On softkey, [62](#)
 - All Down softkey, [1044](#), [1095](#)
 - All softkey, [104](#), [122](#)
 - All Timeslots softkey
 - See* DECT subsystem keys
 - See* EDGE subsystem keys
 - See* GSM subsystem keys
 - See* NADC subsystem keys
 - See* PDC subsystem keys
 - See* PHS subsystem keys

Index

- See* TETRA subsystem keys
- All Up softkey, [1044](#), [1095](#)
- Alt Amp Delta softkey, [63](#)
- Alt Ampl Off On softkey, [64](#)
- Alt power in field, [1152](#)
- alternate amplitude markers
 - awgn arb subsystem, [209](#)
 - cdma subsystem, [222](#)
 - cdma2000 arb subsystem, [257](#)
 - dmodulation subsystem, [276](#)
 - dual arb subsystem, [309](#)
 - multitone arb subsystem, [333](#)
 - multitone subsystem, [333](#)
 - wideband CDMA ARB subsystem, [372](#)
- AM softkeys
 - AM Depth, [177](#)
 - AM Depth Couple Off On, [178](#)
 - AM Off On, [177](#)
 - AM Off On softkey, [173](#)
 - AM Path 1 2, [172](#)
 - AM Stop Rate, [174](#)
 - AM Sweep Rate, [175](#)
 - AM Tone 2 Ampl Percent Of Peak, [175](#)
 - AM Tone 2 Rate, [174](#)
- AM wideband, [173](#)
- AM_ADDR softkey, [470](#)
- Ampl softkeys
 - Ampl, [49](#), [66](#)
 - Ampl Offset, [68](#)
 - Ampl Ref Off On, [67](#)
 - Ampl Ref Set, [66](#)
 - Ampl Start, [49](#), [67](#)
 - Ampl Stop, [49](#), [68](#)
- Amplitude hardkey, [66](#), [69](#)
- amplitude modulation subsystem keys
 - AM Depth, [177](#)
 - AM Depth Couple Off On, [178](#)
 - AM Off On, [173](#), [177](#)
 - AM Path 1 2, [172](#)
 - AM Stop Rate, [174](#)
 - AM Sweep Rate, [175](#)
 - AM Tone 2 Ampl Percent Of Peak, [175](#)
 - AM Tone 2 Rate, [174](#)
 - Bus, [176](#)
 - Dual-Sine, [175](#)
 - Ext, [176](#)
 - Ext Coupling DC AC, [173](#)
 - Ext1, [176](#)
 - Ext2, [176](#)
 - Free Run softkey, [176](#)
 - Incr Set, [172](#), [178](#)
 - Internal, [176](#)
 - Noise, [175](#)
 - Ramp, [175](#)
 - Sine, [175](#)
 - Square, [175](#)
 - Swept-Sine, [175](#)
 - Triangle, [175](#)
 - Trigger Key, [176](#)
- amplitude step, [69](#)
- AMR 12.2 kbps softkey, [1041](#), [1146](#)
- APCO 25 C4FM softkey
 - See* CDMA ARB subsystem keys
 - See* CDMA2000 ARB subsystem keys
 - See* CDMA2000 BBG subsystem keys and fields
 - See* custom subsystem keys
 - See* DECT subsystem keys
 - See* Dmodulation subsystem keys
 - See* dual ARB subsystem keys
 - See* EDGE subsystem keys
 - See* GPS subsystem keys
 - See* GSM subsystem keys
 - See* NADC subsystem keys
 - See* PDC subsystem keys
 - See* PHS subsystem keys
 - See* TETRA subsystem keys
 - See* wideband CDMA ARB subsystem keys
 - See* wideband CDMA base band generator subsystem keys and fields
- APCO 25 w/C4FM softkey, [282](#), [283](#), [284](#)
- APCO 25 w/C4QPSK softkey, [282](#), [283](#), [284](#)
- APCO 25 w/CQPSK softkey, [573](#)
- Apply Channel Setup softkey, [251](#), [255](#), [361](#), [369](#), [1029](#), [1084](#)
- Apply to Waveform softkey, [304](#), [306](#)
- Arb AWGN Off On softkey, [214](#)
- ARB Off On softkey, [328](#)
- ARB Reference Ext Int softkey
 - See* AWGN subsystem keys
 - See* bluetooth subsystem keys

See CDMA ARB subsystem keys
See CDMA2000 ARB subsystem keys
See Dmodulation subsystem keys
See dual ARB subsystem keys
See multitone subsystem keys
See wideband CDMA ARB subsystem keys
 ARB Sample Clock softkey, [213](#), [228](#), [262](#), [282](#),
 [317](#), [339](#), [377](#), [484](#)
 arbitrary waveform
 runtime scaling, [316](#), [339](#)
 scaling files, [316](#)
 Atten Hold Off On softkey, [65](#)
 Auto softkey, [58](#), [59](#)
 automatic leveling control, [62](#)
 Aux I/O Trigger Polarity Pos Neg softkey, [466](#)
 Aux softkey
 See sense subsystem keys
 Auxiliary Software Options softkey, [82](#)
 AWGN Off On softkey, [474](#)
 AWGN subsystem keys
 1048576, [212](#)
 131072, [212](#)
 16384, [212](#)
 2.100 MHz, [208](#)
 262144, [212](#)
 32768, [212](#)
 40.000 MHz, [205](#), [208](#)
 524288, [212](#)
 65536, [212](#)
 Arb AWGN Off On, [214](#)
 ARB Reference Ext Int, [213](#)
 ARB Sample Clock, [213](#)
 Bandwidth, [205](#)
 Clear Header, [206](#)
 I/Q Mod Filter Manual Auto, [208](#)
 I/Q Output Filter Manual Auto, [206](#)
 Marker 1, [209](#), [210](#)
 Marker 1 Polarity Neg Pos, [212](#)
 Marker 2, [209](#), [210](#)
 Marker 2 Polarity Neg Pos, [212](#)
 Marker 3, [209](#), [210](#)
 Marker 3 Polarity Neg Pos, [212](#)
 Marker 4, [209](#), [210](#)
 Marker 4 Polarity Neg Pos, [212](#)
 Modulator Atten Manual Auto, [207](#)

Noise Seed Fixed Random, [214](#)
 None, [209](#), [210](#)
 Reference Freq, [212](#)
 Save Setup To Header, [206](#)
 Through, [205](#), [208](#)
 Waveform Length, [212](#)

B

B softkey, [1006](#), [1011](#), [1033](#)
 B1 softkey, [1004](#), [1009](#)
 B2 softkey, [1004](#), [1009](#)
 Bandwidth softkey, [205](#), [469](#)
 Base Delay Tp-a softkey, [1136](#)
 BBG Chip Clock Ext Int softkey
 See wideband CDMA base band generator
 subsystem keys and fields
 BBG Data Clock Ext Int softkey
 See custom subsystem keys
 See DECT subsystem keys
 See GSM subsystem keys
 See NADC subsystem keys
 See PHS subsystem keys
 See TETRA subsystem keys
 BBG Data Clock field, [486](#)
 BBG Ref Ext Int softkey
 See custom subsystem keys
 See DECT subsystem keys
 See EDGE subsystem keys
 See GSM subsystem keys
 See NADC subsystem keys
 See PDC subsystem keys
 See PHS subsystem keys
 See TETRA subsystem keys
 BBG1 softkey, [24](#), [35](#)
 BD_ADDR softkey, [470](#)
 Begin Data Format Pattern Framed softkey
 See DECT subsystem keys
 See EDGE subsystem keys
 See GSM subsystem keys
 See NADC subsystem keys
 See PDC subsystem keys
 See PHS subsystem keys
 See TETRA subsystem keys
 Begin Frame softkey
 See DECT subsystem keys

Index

- See* EDGE subsystem keys
- See* GSM subsystem keys
- See* NADC subsystem keys
- See* PDC subsystem keys
- See* PHS subsystem keys
- See* TETRA subsystem keys
- Begin Timeslot # softkey
 - See* DECT subsystem keys
 - See* EDGE subsystem keys
 - See* GSM subsystem keys
 - See* NADC subsystem keys
 - See* PDC subsystem keys
 - See* PHS subsystem keys
 - See* TETRA subsystem keys
- BER Display % Exp softkey, [413](#)
- BER field, [1175](#), [1182](#)
- BER Mode Off On softkey
 - See* sense subsystem keys
- BER softkey, [1177](#), [1184](#)
- BERT Off On softkey, [463](#)
- BERT Resync Off On softkey, [463](#)
- Beta field, [1088](#), [1098](#)
- Binary softkey, [94](#), [124](#)
- binary values, [18](#)
- Bit Count softkey
 - See* sense subsystem keys
- Bit Delay Off On softkey, [465](#)
- Bit Order softkey, [390](#)
- Bit Rate field
 - See* CDMA2000 BBG subsystem keys and fields
- Bit softkey, [94](#)
- BLER field, [1176](#), [1183](#)
- BLER softkey, [1177](#), [1184](#)
- Blk Set Size field, [1075](#)
- Blk Size field, [1074](#), [1171](#), [1179](#)
- Block Count softkey
 - See* calculate subsystem keys
 - See* sense subsystem keys
- Block Erasure softkey
 - See* sense subsystem keys
- Blocking softkey, [1072](#)
- Bluetooth Off On softkey, [484](#)
- Bluetooth softkey, [573](#)
- bluetooth subsystem keys
 - 2.100 MHz, [479](#)
 - 40.000 MHz, [472](#), [479](#)
 - 8 Bit Pattern, [471](#)
 - AM_ADDR, [470](#)
 - ARB Reference Ext Int, [483](#)
 - ARB Sample Clock, [484](#)
 - AWGN Off On, [474](#)
 - BD_ADDR, [470](#)
 - Bluetooth Off On, [484](#)
 - Burst Off On, [470](#)
 - Burst Power Ramp, [484](#)
 - C/N[1 MHz], [474](#)
 - Clear Header, [473](#)
 - Clock/Gate Delay, [471](#)
 - Continuous PN9, [471](#)
 - Drift Deviation, [475](#)
 - Freq Drift Type Linear Sine, [476](#)
 - Freq Offset, [476](#)
 - I/Q Mod Filter Manual Auto, [480](#)
 - I/Q Output Filter Manual Auto, [472](#)
 - Impairments Off On, [473](#)
 - Marker 1, [480](#), [481](#)
 - Marker 1 Polarity Neg Pos, [481](#)
 - Marker 2, [480](#), [481](#)
 - Marker 2 Polarity Neg Pos, [482](#)
 - Marker 3, [480](#), [481](#)
 - Marker 3 Polarity Neg Pos, [482](#)
 - Marker 4, [480](#), [481](#)
 - Marker 4 Polarity Neg Pos, [482](#)
 - Mod Index, [477](#)
 - Modulator Atten Manual Auto, [478](#), [479](#)
 - Noise Seed, [475](#)
 - None, [480](#), [481](#)
 - Packet (DH1), [482](#)
 - Reference Freq, [483](#)
 - Save Setup To Header, [473](#)
 - Symbol Timing Err, [478](#)
 - Through, [472](#), [479](#)
 - Truncated PN9, [471](#)
- boolean SCPI parameters, [10](#)
- boolean, numeric response data, [11](#)
- BPSK softkey
 - See* custom subsystem keys
 - See* DECT subsystem keys
 - See* Dmodulation subsystem keys
 - See* EDGE subsystem keys

- See* GSM subsystem keys
- See* NADC subsystem keys
- See* PDC subsystem keys
- See* PHS subsystem keys
- See* TETRA subsystem keys
- Brightness softkey, [86](#)
- Build New Waveform Sequence softkey, [317](#)
- burst
 - shape, [115](#)
- Burst Envelope Int Ext Off softkey, [22](#)
- Burst gate in field, [1153](#)
- Burst Gate In Polarity Neg Pos softkey, [130](#), [131](#)
- Burst Off On softkey, [470](#)
- Burst Power Ramp softkey, [484](#)
- Bus softkey
 - list trigger source, [54](#)
 - See* amplitude modulation subsystem keys
 - See* CDMA ARB subsystem keys
 - See* CDMA2000 ARB subsystem keys
 - See* DECT subsystem keys
 - See* Dmodulation subsystem keys
 - See* dual ARB subsystem keys
 - See* EDGE subsystem keys
 - See* frequency modulation subsystem keys
 - See* GSM subsystem keys
 - See* low frequency output subsystem keys
 - See* NADC subsystem keys
 - See* PDC subsystem keys
 - See* phase modulation subsystem keys
 - See* PHS subsystem keys
 - See* sense subsystem keys
 - See* TETRA subsystem keys
 - See* trigger subsystem keys
 - See* wideband CDMA ARB subsystem keys
- C**
- C Power field, [1085](#), [1115](#)
- C/N softkey, [511](#), [523](#)
- C/N value field, [1029](#), [1084](#), [1114](#)
- C/N[1 MHz] softkey, [474](#)
- C4FM softkey, [969](#)
- calculate subsystem keys
 - BER Display % Exp, [413](#)
 - Block Count, [431](#)
 - Class II RBER, [410](#), [411](#)
 - Class Ib RBER, [410](#), [411](#)
 - Cycle End, [411](#)
 - Error Rate, [404](#), [405](#), [406](#), [407](#), [408](#), [409](#)
 - Exceeds Any Limit, [411](#)
 - Fail Hold, [411](#)
 - Frame Erasure, [410](#), [411](#)
 - No Limits, [405](#), [408](#), [409](#), [411](#)
 - Pass/Fail Limits, [412](#)
 - Pass/Fail Off On, [412](#)
 - Update Display Cycle End Cont, [413](#)
- calibration subsystem keys
 - DCFM/DCΦM Cal, [72](#)
 - Execute Cal, [72](#), [73](#)
 - I/Q Calibration, [72](#)
 - Revert to Default Cal Settings, [73](#)
 - Start Frequency, [74](#)
 - Stop Frequency, [74](#)
- Carrier Bandwidth softkey, [313](#)
- Carrier Phases Fixed Random softkey, [283](#)
- Carrier to Noise Ratio softkey, [313](#)
- CC softkey, [933](#), [937](#), [939](#)
- CDL softkey, [900](#)
- CDMA ARB subsystem keys
 - 2.100 MHz, [222](#)
 - 3 Carriers, [230](#)
 - 32 Ch Fwd, [228](#), [231](#)
 - 4 Carriers, [230](#)
 - 40.000 MHz, [217](#), [222](#)
 - 64 Ch Fwd, [228](#), [231](#)
 - 9 Ch Fwd, [228](#), [231](#)
 - APCO 25 C4FM, [218](#)
 - ARB Reference Ext Int, [227](#)
 - ARB Sample Clock, [228](#)
 - Bus, [235](#)
 - CDMA Off On, [239](#)
 - Chip Rate, [216](#)
 - Clear Header, [220](#)
 - Clip |I+jQ| To, [216](#)
 - Clip |I| To, [215](#)
 - Clip |Q| To, [215](#)
 - Clip At PRE POST FIR Filter, [215](#)
 - Clipping Type |I+jQ| |I|,|Q|, [216](#)
 - Continuous, [233](#), [263](#)
 - CPICH, [362](#)
 - Custom CDMA Multicarrier, [230](#)

Index

Custom CDMA State, [228](#), [231](#)
Equal Powers, [229](#)
Ext, [235](#)
Ext Delay Off On, [237](#)
Ext Delay Time, [236](#)
Ext Polarity Neg Pos, [237](#)
Filter Alpha, [219](#)
Filter BbT, [219](#)
Free Run, [234](#)
Gate Active Low High, [235](#)
Gated, [233](#), [263](#)
Gaussian, [218](#)
I/Q Mapping Normal Invert, [221](#)
I/Q Mod Filter Manual Auto, [222](#)
I/Q Output Filter Manual Auto, [217](#)
Immediate, [227](#)
IS-2000 SR3 DS, [218](#)
IS-95, [218](#)
IS-95 Mod, [218](#)
IS-95 Mod w/EQ, [218](#)
IS-95 w/EQ, [218](#)
IS-97 Levels, [229](#)
Marker 1, [222](#), [223](#), [224](#)
Marker 1 Polarity Neg Pos, [226](#)
Marker 2, [222](#), [223](#), [224](#)
Marker 2 Polarity Neg Pos, [226](#)
Marker 3, [222](#), [223](#), [224](#)
Marker 3 Polarity Neg Pos, [226](#)
Marker 4, [222](#), [223](#), [224](#)
Marker 4 Polarity Neg Pos, [226](#)
Modulator Atten Manual Auto, [221](#)
Multicarrier Off On, [228](#)
None, [222](#), [223](#), [224](#)
Nyquist, [218](#)
Off, [227](#)
On, [227](#)
Optimize FIR For EVM ACP, [220](#)
Oversample Ratio, [226](#)
Paging, [229](#)
Patt Trig In 1, [238](#)
Patt Trig In 2, [238](#)
Pilot, [228](#), [229](#), [231](#)
Rectangle, [218](#)
Reference Freq, [226](#)
Reset & Run, [234](#)
Reverse, [228](#)
Root Nyquist, [218](#)
Save Setup To Header, [220](#)
Scale to 0dB, [229](#)
Single, [233](#), [263](#)
Store Custom CDMA State, [232](#)
Store Custom Multicarrier, [231](#)
Sync, [229](#)
Through, [217](#), [222](#)
Traffic, [229](#)
Trigger & Run, [234](#)
Trigger Key, [235](#)
UN3/4 GSM Gaussian, [218](#)
User FIR, [218](#)
Waveform Length, [238](#)
WCDMA, [218](#)
CDMA Freq field, [505](#)
CDMA Off On softkey, [239](#)
CDMA softkey, [95](#)
CDMA2000 ARB subsystem keys
 1.23 MHz, [263](#)
 1.25 MHz, [263](#)
 2 SR3 Carriers, [248](#)
 2.100 MHz, [246](#)
 3 Carriers, [248](#)
 4 Carriers, [248](#)
 40.000 MHz, [241](#), [246](#)
 5 Channel, [254](#)
 8 Channel, [254](#)
 9 Channel, [247](#)
 APCO 25 C4FM, [242](#)
 Apply Channel Setup, [251](#), [255](#)
 ARB Reference Ext Int, [260](#)
 ARB Sample Clock, [262](#)
 Bus, [266](#)
 CDMA2000 Off On, [269](#)
 Clear Header, [245](#)
 Clip |I+jQ| To, [241](#)
 Clip |I| To, [240](#)
 Clip |Q| To, [240](#)
 Clip At PRE POST FIR Filter, [240](#)
 Clipping Type |I+jQ| |I|,|Q|, [241](#)
 Config, [252](#), [255](#)
 Continuous, [263](#)
 Custom CDMA2000 Carrier, [247](#), [249](#)

- Custom CDMA2000 Multicarrier, 248
- Custom CDMA2000 State, 254
- Edit Channel Setup, 252, 255
- Equal Powers, 253, 256
- Ext, 266
- Ext Delay Off On, 268
- Ext Delay Time, 267
- Ext Polarity Neg Pos, 268
- Filter Alpha, 243
- Filter BbT, 244
- Free Run, 265
- Gate Active Low High, 266
- Gated, 263
- Gaussian, 242
- I/Q Mapping Normal Invert, 247
- I/Q Mod Filter Manual Auto, 246
- I/Q Output Filter Manual Auto, 242
- Immediate, 261
- Insert Row, 252, 255
- IS-2000 SR3 DS, 242
- IS-95, 242
- IS-95 Mod, 242
- IS-95 Mod w/EQ, 242
- IS-95 w/EQ, 242
- Link Forward Reverse, 247
- Marker 1, 257, 258
- Marker 1 Polarity Neg Pos, 260
- Marker 2, 257, 258
- Marker 2 Polarity Neg Pos, 260
- Marker 3, 257, 258
- Marker 3 Polarity Neg Pos, 260
- Marker 4, 257, 258
- Marker 4 Polarity Neg Pos, 260
- Modulator Atten Manual Auto, 245, 246
- Multicarrier Off On, 247
- None, 257, 258
- Nyquist, 242
- Off, 261
- On, 261
- Optimize FIR For EVM ACP, 244
- Patt Trig In 1, 269
- Patt Trig In 2, 269
- Pilot, 247, 254
- PN Offset, 252, 255
- Radio Config, 253
- Rate, 252, 255
- Rectangle, 242
- Reference Freq, 260
- Reset & Run, 265
- Root Nyquist, 242
- Save Setup To Header, 245
- Scale to 0dB, 253, 256
- Single, 263
- Spread Rate 1, 247, 254, 262
- Spread Rate 3, 247, 254, 262
- Spreading Type Direct Mcarrier, 247, 263
- SR1 9 Channel, 249
- SR1 Pilot, 249
- SR3 Direct 9 Channel, 249
- SR3 Direct Pilot, 249
- SR3 Mcarrier 9 Channel, 249
- SR3 MCarrier Pilot, 249
- Store Custom CDMA State, 251, 254
- Store Custom Multicarrier, 249
- Through, 241, 246
- Trigger & Run, 265
- Trigger Key, 266
- UN3/4 GSM Gaussian, 242
- User FIR, 242
- Walsh Code, 252, 255
- WCDMA, 242
- CDMA2000 BBG subsystem keys and fields
 - APCO 25 C4FM, 487, 520
 - BBG Data Clock, 486
 - Bit Rate, 494, 498, 503, 517, 527, 529, 533, 538, 543, 547, 550
 - C/N, 511, 523
 - CDMA Freq, 505
 - CDMA2000 Off On, 553
 - Change, 515
 - Chip Rate, 486, 519
 - DAYLT, 505
 - EbNo, 490, 495, 501, 506, 512, 515, 525, 531, 533, 537, 542, 545, 548
 - EcNo, 499, 534, 539
 - Equal Powers, 514, 523
 - Even Second Delay, 486, 519
 - Ext, 489, 500, 528
 - Ext CDMA Freq, 506
 - External, 518

Index

- Falling, 553
- Field 1, 496
- Field 2, 496
- Field 3, 497
- Filter Alpha, 488, 521
- Filter BbT, 488, 491, 521
- FIX4, 489, 490, 500, 524, 525, 528, 530, 531, 536, 541, 545, 548
- Frame Length, 526, 528, 532, 542, 546, 549
- Frame Offset, 501, 526, 529, 532, 537, 542, 546, 549
- FSYNCH Type, 510
- Full, 535, 540
- Gaussian, 487, 520
- Half, 535, 540
- Header, 492, 502
- Internal, 518
- Inverted, 523
- IS-95, 487, 520
- IS-95 MOD, 520
- IS-95 Mod, 487
- IS-95 MOD w/EQ, 520
- IS-95 Mod w/EQ, 487
- IS-95 w/EQ, 487, 520
- Leap Seconds, 507
- Link Forward Reverse, 485
- Long Code Mask, 522
- Long Code State, 489, 522
- LTM OFF, 507
- Message Type, 508
- Network ID, 508
- Noise Off On, 512, 524
- Normal, 523
- Nyquist, 487, 520
- Optimize FIR For EVM ACP, 488, 522
- P Rev, 509
- P Rev Min, 507
- Paging Indicator, 516
- Permuted ESN, 492, 502
- Phase Polarity, 515
- PN Offset, 518
- PN15, 489, 500, 524, 528, 530, 536, 541, 544, 548
- PN9, 489, 500, 524, 528, 530, 536, 541, 544, 548
- Power, 492, 497, 499, 503, 508, 513, 516, 526, 529, 532, 535, 538, 540, 543, 546, 550
- PRAT, 509
- QOF, 493, 503
- Quarter, 535, 540
- Radio Config, 494, 504, 527, 530, 538, 543, 547, 550
- RadioConfig 1/2 Access, 485
- RadioConfig 1/2 Traffic, 485
- RadioConfig 3/4 Common Control, 485
- RadioConfig 3/4 Enhanced Access, 485
- RadioConfig 3/4 Traffic, 485
- Ramp, 493
- Ramp Time, 493
- Rectangle, 487, 520
- Reserved, 509
- Rising, 553
- Root Nyquist, 487, 520
- Scale to 0dB, 514, 523
- Spread Rate, 517
- State, 498, 500, 505, 511, 514, 517, 527, 530, 534, 536, 539, 541, 544, 547, 551
- State field, 495
- System ID, 510
- Time, 510
- Trigger Advance, 552
- Turbo Coding, 504, 551
- UN3/4 GSM Gaussian, 487, 520
- User File, 489, 495, 500, 524, 528, 530, 536, 541, 544, 548
- User FIR, 487, 520
- Walsh, 498, 504, 511, 514, 517, 533, 535, 539, 540, 544, 547, 551
- Walsh field, 494
- CDMA2000 Off On softkey, 269, 553
- CDPD softkey, 282, 283, 284, 573
- CDVCC softkey, 900, 903
- CFN #0 Frame Pulse (RPS10) softkey
 - See wideband CDMA base band generator subsystem keys and fields
- Chan Code field, 1039, 1048
- Chan Code softkey, 1038
- Change field, 515
- Channel Code field, 1099, 1140
 - See wideband CDMA base band generator subsystem keys and fields
- Channel Number softkey, 40

- Channel softkey, 361, 369
- Channel State field, 1098, 1105
- Channel State Off On softkey, 1117
 - See* wideband CDMA base band generator subsystem keys and fields
- ChCode Ctl field, 1130
- ChCode Dat field, 1130
- Chip Clock (RPS1) softkey
 - See* wideband CDMA base band generator subsystem keys and fields
- Chip Rate field, 486, 519, 1038, 1088
- Chip Rate softkey, 216, 346
- Class Ib Bit Error softkey, 457, 458
- Class II Bit Error softkey, 458
- Class II RBER softkey, 410, 411
- Class Ib RBER softkey, 410, 411
- Clear Header softkey, 206, 220, 245, 273, 298, 330, 348, 473
- clearing markers, 304
- Clip |I+jQ| To softkey, 216, 241
- Clip |I| To softkey, 215, 240, 344, 355
- Clip |Q| To softkey, 215, 240, 344, 356
- Clip At PRE POST FIR Filter, 215
- Clip At PRE POST FIR Filter softkey, 240, 344
- Clip Type |I+jQ| To softkey, 345, 356
- Clipping Type |I+jQ| |I|,|Q| softkey, 216, 241, 294, 345, 356
- Clock Delay Off On softkey, 425
- Clock Per Sample softkey, 386
- Clock Phase softkey, 386
- Clock Polarity Neg Pos softkey, 426
- Clock Polarity softkey, 387
- Clock Rate softkey, 388
- Clock Skew softkey, 389
- Clock Source softkey, 389
- Clock Time Delay softkey, 425
- Clock/Gate Delay softkey, 471
- command tree, SCPI, 6, 7
- Common Mode I/Q Offset softkey, 26
- communication subsystem keys
 - Default Gateway, 76
 - GPIB Address, 75
 - Hostname, 76
 - IP Address, 76
 - LAN Config, 75
 - Meter Address, 77
 - Meter Channel A B, 77
 - Meter Timeout, 78
 - Power Meter, 78
 - Reset RS-232, 79
 - RS-232 Baud Rate, 79
 - RS-232 ECHO Off On, 79
 - RS-232 Timeout, 80
 - Subnet Mask, 77
- Comp Mode Start Trigger Polarity Neg Pos softkey, 1169
- Comp Mode Start Trigger Polarity Pos Neg softkey, 1070, 1071
- Comp Mode Stop Trigger Polarity Neg Pos softkey, 1169
- Comp Mode Stop Trigger Polarity Pos Neg softkey, 1071
- Compressed Frame (RPS8) softkey
 - See* wideband CDMA base band generator subsystem keys and fields
- Compressed Mode Off On softkey, 1168
- Compressed Mode Start Trigger softkey, 1047, 1070, 1169
- Compressed Mode Stop Trigger softkey, 1071, 1169
- Config softkey, 252, 255
- Configure Cal Array softkey, 20
- continuous
 - segment advance, 322
- Continuous PN9 softkey, 471
- Continuous softkey
 - dual ARB subsystem keys, 322
 - See* CDMA ARB subsystem keys
 - See* CDMA2000 ARB subsystem keys
 - See* custom subsystem keys
 - See* DECT subsystem keys
 - See* Dmodulation subsystem keys
 - See* dual ARB subsystem keys
 - See* EDGE subsystem keys
 - See* GSM subsystem keys
 - See* NADC subsystem keys
 - See* PDC subsystem keys
 - See* PHS subsystem keys
 - See* TETRA subsystem keys
 - See* wideband CDMA ARB subsystem keys
- Copy File softkey, 105, 114, 124

Index

- correction subsystem keys
 - Configure Cal Array, [20](#)
 - Flatness Off On, [21](#)
 - Load From Selected File, [20](#)
 - Preset List, [21](#)
 - Store To File, [21](#)
- CPICH softkey, [362](#)
- CRC Size field, [1077](#), [1173](#), [1180](#)
- creating a waveform
 - sequence, dual ARB, [317](#)
- creating a waveform, multitone, [330](#)
- CS-1 softkey, [648](#), [649](#), [800](#)
- CS-4 softkey, [648](#), [650](#), [804](#)
- CSID softkey, [961](#), [979](#)
- Ctrl Beta field, [1118](#)
- Ctrl Pwr field, [1119](#)
- Custom CDMA Multicarrier softkey, [230](#)
- Custom CDMA State softkey, [228](#), [231](#)
- Custom CDMA2000 Carrier softkey, [247](#), [249](#)
- Custom CDMA2000 Multicarrier softkey, [248](#)
- Custom CDMA2000 State softkey, [254](#)
- Custom Digital Mod State softkey, [283](#), [284](#)
- Custom Off On softkey, [579](#)
- Custom softkey, [596](#), [607](#), [663](#), [808](#), [964](#)
- custom subsystem keys
 - 128QAM, [570](#)
 - 16 1's & 16 0's, [563](#)
 - 16PSK, [570](#)
 - 16QAM, [570](#)
 - 256QAM, [570](#)
 - 2-Lvl FSK, [570](#)
 - 32 1's & 32 0's, [563](#)
 - 32QAM, [570](#)
 - 4 1's & 4 0's, [563](#)
 - 4-Lvl FSK, [570](#)
 - 4QAM, [570](#)
 - 64 1's & 64 0's, [563](#)
 - 64QAM, [570](#)
 - 8 1's & 8 0's, [563](#)
 - 8PSK, [570](#)
 - APCO 25 C4FM, [567](#)
 - APCO 25 w/CQPSK, [573](#)
 - BBG Data Clock Ext Int, [555](#)
 - BBG Ref Ext Int, [566](#)
 - Bit Rate, [556](#)
 - Bluetooth, [573](#)
 - BPSK, [570](#)
 - Bus, [576](#)
 - CDPD, [573](#)
 - Continuous, [573](#)
 - Custom Off On, [579](#)
 - D8PSK, [570](#)
 - Diff Data Encode Off On, [565](#)
 - Ext, [563](#), [576](#)
 - Ext BBG Ref Freq, [566](#)
 - Ext Data Clock Normal Symbol, [565](#)
 - Ext Delay Bits, [577](#)
 - Ext Delay Off On, [577](#)
 - Ext Polarity Neg Pos, [578](#)
 - Fall Delay, [558](#), [559](#)
 - Fall Time, [558](#), [559](#)
 - Filter Alpha, [554](#)
 - Filter BbT, [555](#)
 - FIX4, [563](#), [564](#)
 - Free Run, [574](#)
 - Freq Dev, [569](#)
 - Gate Active Low High, [574](#)
 - Gated, [573](#)
 - Gaussian, [567](#)
 - Gray Coded QPSK, [570](#)
 - I/Q Scaling, [568](#)
 - IS-95, [567](#)
 - IS-95 Mod, [567](#)
 - IS-95 Mod w/EQ, [567](#)
 - IS-95 OQPSK, [570](#)
 - IS-95 QPSK, [570](#)
 - IS-95 w/EQ, [567](#)
 - MSK, [570](#)
 - None, [573](#)
 - Nyquist, [567](#)
 - Optimize FIR For EVM ACP, [563](#)
 - OQPSK, [570](#)
 - $\pi/4$ DQPSK, [570](#)
 - Patt Trig In 1, [578](#)
 - Patt Trig In 2, [578](#)
 - Phase Dev, [569](#)
 - Phase Polarity Normal Invert, [571](#)
 - PN11, [563](#)
 - PN15, [563](#)
 - PN20, [563](#)

- PN23, [563](#)
 - PN9, [563](#)
 - PRAM Files, [564](#)
 - QPSK, [570](#)
 - Rectangle, [567](#)
 - Reset & Run, [574](#)
 - Rise Delay, [560](#)
 - Rise Time, [561](#), [562](#)
 - Root Nyquist, [567](#)
 - Single, [573](#)
 - Symbol Rate, [571](#)
 - Trigger & Run, [574](#)
 - Trigger Key, [576](#)
 - UN3/4 GSM Gaussian, [567](#)
 - User File, [563](#)
 - User FIR, [567](#)
 - User FSK, [570](#)
 - User I/Q, [570](#)
 - Custom TS softkey, [652](#), [662](#), [799](#), [806](#)
 - Custom WCDMA State softkey, [368](#)
 - Cycle Count softkey, [465](#)
 - Cycle End softkey, [411](#)
- D**
- D8PSK softkey
 - See* custom subsystem keys
 - See* DECT subsystem keys
 - See* Dmodulation subsystem keys
 - See* EDGE subsystem keys
 - See* GSM subsystem keys
 - See* NADC subsystem keys
 - See* PDC subsystem keys
 - See* PHS subsystem keys
 - See* TETRA subsystem keys
 - data
 - memory subsystem, [105](#)
 - data append
 - memory subsystem, [106](#)
 - Data Beta field, [1122](#)
 - data bit, [107](#)
 - data block, [114](#)
 - Data Clock Out Neg Pos softkey, [133](#)
 - Data Clock Polarity Neg Pos softkey, [130](#), [132](#), [134](#)
 - Data field, [1100](#), [1184](#)
 - data files, [105](#)
 - data FSK, [109](#)
 - data IQ, [110](#)
 - Data Mode Raw Enc TLM softkey, [769](#), [770](#)
 - Data Out Polarity Neg Pos softkey, [133](#), [135](#)
 - Data Polarity Neg Pos softkey, [131](#), [132](#), [426](#)
 - Data Pwr field, [1124](#)
 - Data Rate field, [1049](#)
 - data subsystem keys
 - Error Out, [419](#)
 - PN9, [419](#)
 - Reference Out, [419](#)
 - Data Type softkey, [398](#)
 - DATA/CLK/SYNC Rear Outputs Off On softkey, [135](#)
 - DAYLT field, [505](#)
 - dBm softkey, [170](#)
 - dBuV softkey, [170](#)
 - dBuVemf softkey, [170](#)
 - DC softkey, [189](#)
 - DCFM/DCΦM Cal softkey, [72](#)
 - DCH1 softkey, [1086](#)
 - DCH2 softkey, [1086](#)
 - DCH3 softkey, [1086](#)
 - DCH4 softkey, [1086](#)
 - DCH5 softkey, [1086](#)
 - DCH6 softkey, [1086](#)
 - decimal values, [18](#)
 - Dect Off On softkey, [628](#)
 - DECT softkey, [282](#), [283](#), [284](#)
 - DECT subsystem keys
 - 128QAM, [595](#)
 - 16 1's & 16 0's, [589](#), [596](#), [599](#), [602](#), [604](#), [606](#), [607](#), [611](#), [614](#), [616](#), [618](#)
 - 16-Lvl FSK, [589](#)
 - 16PSK, [595](#)
 - 16QAM, [595](#)
 - 256QAM, [595](#)
 - 2-Lvl FSK, [595](#)
 - 32 1's & 32 0's, [589](#), [596](#), [599](#), [602](#), [604](#), [606](#), [607](#), [611](#), [614](#), [616](#), [618](#)
 - 32QAM, [595](#)
 - 4 1's & 4 0's, [589](#), [596](#), [599](#), [602](#), [604](#), [606](#), [607](#), [611](#), [614](#), [616](#), [618](#)
 - 4-Lvl FSK, [595](#)
 - 4QAM, [595](#)

Index

- 64 1's & 64 0's, 589, 596, 599, 602, 604, 606, 607, 611, 614, 616, 618
- 64QAM, 595
- 8 1's & 8 0's, 589, 596, 599, 602, 604, 606, 607, 611, 614, 616, 618
- 8-Lvl FSK, 589
- 8PSK, 595
- A field, 597, 600, 603, 605, 608, 609, 610, 613, 615, 617
- All Timeslots, 621
- APCO 25 C4FM, 592
- BBG Data Clock Ext Int, 580
- BBG Ref Ext Int, 591
- Begin Frame, 621
- Begin Timeslot #, 621, 622
- Bit Rate, 581
- BPSK, 595
- Bus, 620, 625
- Continuous, 623
- Custom, 596, 607
- D8PSK, 595
- Data Format Pattern Framed, 588
- Dect Off On, 628
- DM0, 596, 599, 602, 604, 606, 607, 611, 614, 616, 618
- DM1, 596, 599, 602, 604, 606, 607, 611, 614, 616, 618
- Dummy Bearer 1, 607
- Dummy Bearer 2, 607
- Ext, 589, 596, 599, 602, 604, 606, 607, 611, 614, 616, 618, 620, 625
- Ext Data Clock Normal Symbol, 591
- Ext Delay Bits, 626
- Ext Delay Off On, 628
- Ext Polarity Neg Pos, 627
- FACC, 596, 599, 602, 604, 606, 607, 611, 614, 616, 618
- Fall Delay, 583, 584
- Fall Time, 583, 584
- FDEV1_FS, 596, 599, 602, 604, 606, 607, 611, 614, 616, 618
- FDEV1_HS, 596, 599, 602, 604, 606, 607, 611, 614, 616, 618
- FDEV2_FS, 596, 599, 602, 604, 606, 607, 611, 614, 616, 618
- Filter Alpha, 580
- Filter BbT, 581
- FIX4, 589, 596, 597, 599, 602, 604, 606, 607, 608, 611, 612, 614, 615, 616, 617, 618, 619
- Free Run, 624
- Freq Dev, 593
- Gate Active Low High, 625
- Gated, 623
- Gaussian, 592
- Gray Coded QPSK, 595
- I/Q Scaling, 593
- IS-95, 592
- IS-95 Mod, 592
- IS-95 Mod w/EQ, 592
- IS-95 OQPSK, 595
- IS-95 QPSK, 595
- IS-95 w/EQ, 592
- Low Capacity, 596, 607
- Low Capacity with Z field, 596, 607
- MSK, 595
- Nyquist, 592
- Optimize FIR For EVM ACP, 588
- OQPSK, 595
- P, 598, 601, 603, 605, 609, 610, 611, 613, 615, 617
- $\pi/4$ DQPSK, 595
- Patt Trig In 1, 627
- Patt Trig In 2, 627
- Phase Dev, 594
- Phase Polarity Normal Invert, 595
- PN11, 589, 596, 599, 602, 604, 606, 607, 614, 616, 618
- PN15, 589, 596, 599, 602, 604, 606, 607, 611, 614, 616, 618
- PN20, 589, 596, 599, 602, 604, 606, 607, 614, 616, 618
- PN23, 589, 596, 599, 602, 604, 606, 607, 614, 616, 618
- PN9, 589, 596, 599, 602, 604, 606, 607, 611, 614, 616, 618
- PN9 Mode Normal Quick, 582
- QPSK, 595
- Recall Secondary Frame State, 619
- Rectangle, 592
- Reset & Run, 624
- Restore DECT Factory Default, 590

- Rise Delay, 585
- Rise Time, 586, 587
- Root Nyquist, 592
- S, 598, 601, 603, 605, 609, 610, 611, 614, 616, 618
- Save Secondary Frame State, 619
- Secondary Frame Off On, 620
- Sine, 562, 587
- Single, 623
- Sync Out Offset, 621
- Timeslot Ampl Main Delta, 600, 612
- Timeslot Off On, 600, 613
- Traffic Bearer, 596, 607
- Traffic Bearer with Z field, 596, 607
- Trigger & Run, 624
- Trigger Key, 620, 625
- UN3/4 GSM Gaussian, 592
- User File, 562, 587, 589, 596, 599, 602, 604, 606, 607, 611, 614, 616, 618
- User FIR, 592
- User FSK, 594, 595
- User I/Q, 595
- dect subsystem keys
 - PRAM File, 590
- DECTsubsystem keys
 - Symbol Rate, 622
- Default Gateway softkey, 76
- Delay Bits softkey, 465
- Delete All NVWFM Files softkey, 125
- Delete All WFM Files softkey, 125
- Delete All WFM1 Files softkey, 125
- Delete File softkey, 126
- Delete softkeys
 - Delete All ARB CDMA Files, 118
 - Delete All ARB DMOD Files, 118
 - Delete All ARB DWCDMA Files, 119
 - Delete All ARB FCDMA Files, 119
 - Delete All ARB MCDMA Files, 120
 - Delete All ARB MDMOD Files, 120
 - Delete All ARB MDWCDMA Files, 120
 - Delete All ARB MFCDMA Files, 120
 - Delete All ARB MTONE Files, 121
 - Delete All ARB RCDMA Files, 121
 - Delete All ARB UWCDMA Files, 122
 - Delete All Binary Files, 118
 - Delete All Bit Files, 118
 - Delete All Files, 117
 - Delete All FIR Files, 119
 - Delete All FSK Files, 119
 - Delete All I/Q Files, 119
 - Delete All List Files, 120
 - Delete All SEQ Files, 121
 - Delete All SHAPE Files, 121
 - Delete All State Files, 121
 - Delete All UFLT Files, 122
 - Delete File, 122
- DHCP, 75
- Diagnostic Info softkey, 81, 82, 83, 84, 89
- diagnostic subsystem keys
 - Auxiliary Software Options, 82
 - Diagnostic Info, 81, 82, 83, 84
 - Installed Board Info, 81
 - Options Info, 83
- diagnostic subsystem softkeys
 - Waveform Licenses, 82, 84
- Diff Data Encode Off On softkey, 565, 790
- Diff. Mode I Offset softkey, 26
- Diff. Mode Q Offset softkey, 27
- Digital Modulation Off On softkey, 293
- digital modulation subsystem keys
 - 2.100 MHz, 32
 - 40.000 MHz, 32
 - ALC BW Normal Narrow, 22
 - BBG1, 24, 35
 - Burst Envelope Int Ext Off, 22
 - Common Mode I/Q Offset, 26
 - Diff. Mode I Offset, 26
 - Diff. Mode Q Offset, 27
 - Ext 50 Ohm, 24, 35
 - Ext 600 Ohm, 24, 35
 - Ext In 600 Ohm I Offset, 27
 - Ext In 600 Ohm Q Offset, 28
 - High Crest Mode Off On, 23
 - I Offset, 29
 - I/Q Adjustments Off On, 32
 - I/Q Gain Balance Source 1, 29
 - I/Q Mod Filter Manual Auto, 33
 - I/Q Off On, 37
 - I/Q Out Gain Balance, 27
 - I/Q Output Atten, 28
 - I/Q Timing Skew, 31

Index

- I/Q Timing Skew Path softkey, 32
- Int I/Q Skew Corrections RF BB Off, 35
- Int Phase Polarity Normal Invert, 24, 34
- Modulator Atten Manual Auto, 33, 34
- Off, 24, 35
- Q Offset, 30
- Quadrature Angle Adjustment, 25, 30
- Sum, 24
- Summing Ratio (SRC1/SRC2) x.xx dB, 36
- Through, 32
- digital signal interface module, 386
- digital subsystem softkeys, 393
 - Bit Order, 390
 - Clock Per Sample, 386
 - Clock Phase, 386
 - Clock Polarity, 387
 - Clock Rate, 388
 - Clock Skew, 389
 - Clock Source, 389
 - Data Type, 398
 - Direction, 391
 - Frame Polarity, 393
 - I Gain, 391
 - I Offset, 392
 - IQ Polarity, 394
 - Logic Type, 399
 - Loop Back Test Type, 399
 - N5102A Off On, 401
 - Negate I, 392
 - Negate Q, 395
 - Pass Through Preset, 401
 - Port Config, 400
 - Q Gain, 394
 - Q Offset, 396
 - Reference Frequency, 388
 - Rotation, 396
 - Scaling, 397
 - Signal Type, 398
 - Swap IQ, 393
 - Word Alignment, 390
 - Word Size, 397
- Direction softkey, 391
- discrete response data, 11
- discrete SCPI parameters, 9
- display
 - secure mode, 160
- display contrast hardkeys, 86
- display subsystem keys
 - Brightness, 86
 - display contrast, 86
 - Inverse Video Off On, 87
 - Update in Remote Off On, 87
- DL Reference 1.1 softkey, 1167
 - wideband CDMA base band generator subsystem softkeys
 - DL Reference 1.1, 1069
- DL Reference 1.2 softkey, 1167
 - wideband CDMA base band generator subsystem softkeys
 - DL Reference 1.2, 1069
- DL Reference 2.1 softkey, 1167
 - wideband CDMA base band generator subsystem softkeys
 - DL Reference 2.1, 1069
- DL Reference 2.2 softkey, 1167
 - wideband CDMA base band generator subsystem softkeys
 - DL Reference 2.2, 1069
- DM0 softkey
 - See DECT subsystem keys
- DM1 softkey
 - See DECT subsystem keys
- DMOD softkey, 95
- Dmodulation subsystem keys
 - # of Carriers, 283, 285
 - 128QAM, 279
 - 16PSK, 279
 - 16QAM, 279
 - 2.100 MHz, 275
 - 256QAM, 279
 - 2-Lvl FSK, 279
 - 32QAM, 279
 - 40.000 MHz, 270, 275
 - 4-Lvl FSK, 279
 - 4QAM, 279
 - 64QAM, 279
 - 8PSK, 279
 - APCO 25 C4FM, 271
 - APCO 25 w/C4FM, 282, 283, 284
 - APCO 25 w/C4QPSK, 282, 283, 284

ARB Reference Ext Int, 281
ARB Sample Clock, 282
BPSK, 279
Bus, 290
Carrier Phases Fixed Random, 283
CDPD, 282, 283, 284
Clear Header, 273
Continuous, 287
Custom Digital Mod State, 283, 284
D8PSK, 279
DECT, 282, 283, 284
Digital Modulation Off On, 293
EDGE, 282, 283, 284
Ext, 290
Ext Delay Off On, 291
Ext Delay Time, 291
Ext Polarity Neg Pos, 292
Filter Alpha, 272
Filter BbT, 272
Free Run, 288
Freq Dev, 279
Freq Spacing, 283
Gate Active Low High, 289
Gated, 287
Gaussian, 271
Gray Coded QPSK, 279
GSM, 282, 283, 284
I/Q Mod Filter Manual Auto, 275
I/Q Output Filter Manual Auto, 270
Immediate, 281
Initialize Table, 284
Insert Row, 249, 284
IS-2000 SR3 DS, 271
IS-95, 271
IS-95 Mod, 271
IS-95 Mod w/EQ, 271
IS-95 OQPSK, 279
IS-95 QPSK, 279
IS-95 w/EQ, 271
Load/Store, 284
Marker 1, 276, 277
Marker 1 Polarity Neg Pos, 280
Marker 2, 276, 277
Marker 2 Polarity Neg Pos, 280
Marker 3, 276, 277
Marker 3 Polarity Neg Pos, 280
Marker 4, 276, 277
Marker 4 Polarity Neg Pos, 280
Modulator Atten Manual Auto, 274
MSK, 279
Multicarrier Off On, 282
NADC, 282, 283, 284
None, 276, 277
Nyquist, 271
Off, 281
On, 281
Optimize FIR For EVM ACP, 273
OQPSK, 279
 $\pi/4$ DQPSK, 279
Patt Trig In 1, 292
Patt Trig In 2, 292
PDC, 282, 283, 284
PHS, 282, 283, 284
PWT, 282, 283, 284
QPSK, 279
Rectangle, 271
Reference Freq, 212, 280
Reset & Run, 288
Root Nyquist, 271
Save Setup To Header, 273
Select File, 249, 282
Single, 287
Store Custom Dig Mod State, 285
Symbol Rate, 286
TETRA, 282, 283, 284
Through, 270, 275
Trigger & Run, 288
Trigger Key, 290
UN3/4 GSM Gaussian, 271
User FIR, 271
WCDMA, 271
Dn Custom Cont softkey, 1017
Dn Normal Cont softkey, 1017
Dn Normal Disc softkey, 1017
Dn Sync Cont softkey, 1017
Dn Sync Disc softkey, 1017
Do Power Search softkey, 60, 62
documentation, lxxi
Doppler Shift softkey, 770
Down Custom softkey, 905, 940

Index

- Down TCH All softkey, [905](#), [940](#)
- Down TCH softkey, [905](#), [940](#)
- Down/Up softkey, [1044](#), [1095](#)
- Downlink MCS-1 softkey, [648](#), [650](#), [800](#)
- Downlink MCS-5 softkey, [653](#)
- Downlink MCS-9 softkey, [653](#)
- downloading files, [116](#)
- DPCCH + 1 DPDCH softkey, [368](#)
- DPCCH + 2 DPDCH softkey, [368](#)
- DPCCH + 3 DPCCH softkey, [368](#)
- DPCCH + 4 DPDCH softkey, [368](#)
- DPCCH + 5 DPDCH softkey, [368](#)
- DPCCH Pilot data-clk (DRPS23) softkey, [1058](#),
[1060](#), [1061](#), [1062](#), [1063](#)
- DPCCH Power field, [1092](#)
- DPCCH Raw Data (RPS4) softkey
See wideband CDMA base band generator
subsystem keys and fields
- DPCCH Raw Data Clock (RPS5) softkey
See wideband CDMA base band generator
subsystem keys and fields
- DPCCH softkey, [368](#), [1086](#), [1109](#)
- DPCCH TFC I data-clk (DRPS22) softkey, [1058](#),
[1060](#), [1061](#), [1062](#), [1063](#)
- DPCCH TPC indicator (DRPS21) softkey, [1058](#),
[1060](#), [1061](#), [1062](#), [1063](#)
- DPCH + 1 softkey, [1030](#), [1031](#)
- DPCH + 2 softkey, [1030](#), [1031](#)
- DPCH Channel Balance softkey, [1038](#)
- DPCH Compressed Frame Indicator (DRPS32)
softkey, [1058](#), [1060](#), [1061](#), [1062](#), [1063](#)
- DPCH data stream (DRPS24) softkey, [1058](#), [1060](#),
[1061](#), [1062](#), [1063](#)
- DPCH data-clk (0) (DRPS28) softkey, [1058](#), [1060](#),
[1061](#), [1062](#), [1063](#)
- DPCH Gap Indicator (DRPS33) softkey, [1058](#),
[1060](#), [1061](#), [1062](#), [1063](#)
- DPCH softkey, [362](#)
- DPCH TimeSlot pulse (DRPS25) softkey, [1058](#),
[1060](#), [1061](#), [1062](#), [1063](#)
- DPCH10ms Frame-Pulse (DRPS26) softkey, [1058](#),
[1060](#), [1061](#), [1062](#), [1063](#)
- DPDCH data-clk withDTX (DRPS20) softkey,
[1058](#), [1060](#), [1061](#), [1062](#), [1063](#)
- DPDCH data-clk WithOutDTX (DRPS30) softkey,
[1058](#), [1060](#), [1061](#), [1062](#), [1063](#)
- DPDCH Power field, [1101](#)
- DPDCH Raw Data (RPS2) softkey
See wideband CDMA base band generator
subsystem keys and fields
- DPDCH Raw DataClock (RPS3) softkey
See wideband CDMA base band generator
subsystem keys and fields
- DPDCH softkey, [1086](#)
- Drift Deviation softkey, [475](#)
- dual ARB subsystem
 - generate sine, [297](#)
 - markers, *See* markers
 - runtime scaling, [316](#)
 - scaling waveform files, [316](#)
 - Through, [302](#)
- dual ARB subsystem keys
 - # Skipped Points, [306](#)
 - 2.100 MHz, [303](#)
 - 40.000 MHz, [302](#), [303](#)
 - APCO 25 C4FM, [296](#)
 - Apply to Waveform, [304](#), [306](#)
 - ARB Off On, [328](#)
 - ARB Reference Ext Int, [23](#), [315](#)
 - ARB Sample Clock, [317](#)
 - Build New Waveform Sequence, [317](#)
 - Bus, [324](#)
 - Carrier Bandwidth, [313](#)
 - Carrier to Noise Ratio, [313](#)
 - Clear Header, [298](#)
 - Clipping Type $|I+jQ|$ $|I|,|Q|$, [294](#)
 - Continuous, [322](#)
 - EDGE, [296](#)
 - EDGE EHSR, [296](#)
 - EDGE Wide, [296](#)
 - Edit Noise RMS Override, [298](#)
 - Edit Repetitions, [317](#)
 - Ext, [324](#)
 - Ext Delay, [325](#)
 - Ext Delay Samples, [325](#)
 - Ext Delay Time, [326](#)
 - Ext Polarity Neg Pos, [326](#)
 - Filter Alpha, [294](#)
 - Filter BbT, [295](#)

First Mkr Point, 304, 306
 Free Run, 321
 Gate Active Low High, 321
 Gated, 319
 Gaussian, 296
 Header RMS, 298, 299
 I/Q Mod Filter Manual Auto, 304
 I/Q Output Filter Manual Auto, 301, 302
 Immediate, 315
 Insert Waveform, 317
 IS-95, 296
 IS-95 Mod, 296
 IS-95 Mod w/EQ, 296
 IS-95 w/EQ, 296
 Last Mkr Point, 304, 306
 Marker 1, 309
 Marker 1 2 3 4, 304
 Marker 2, 309
 Marker 3, 309
 Marker 4, 309
 Marker Polarity Neg Pos, 312, 337, 375, 481
 Markers, 306, 310
 Modulation Filter Off On, 297
 Modulator Atten Manual Auto, 302, 303
 Name and Store, 317
 Noise Bandwidth Factor, 312
 None, 309, 310
 Nyquist, 296
 Off, 315, 325
 On, 315
 Optimize FIR For EVM ACP, 295
 Patt Trig In 1, 327
 Patt Trig In 2, 327
 Real-time Noise Off On, 314
 Rectangle, 296
 Reference Freq, 314
 Reset & Run, 321
 Samples, 325
 Save Setup To Header, 301
 Scale Waveform Data, 316
 Scaling, 316
 Segment Advance, 319
 Select Waveform, 327, 328
 Set Marker Off All Points, 305
 Set Marker Off Range Of Points, 304

Set Marker On Range Of Points, 306
 Single, 319, 322
 Through, 302, 303
 Time, 325
 Toggle Marker 1 2 3 4, 317
 Trigger & Run, 321
 Trigger Key, 324
 UN3/4 GSM Gaussian, 296
 User FIR, 296
 Waveform Runtime Scaling, 316
 WCDMA, 296
 dual arb subsystem keys
 Root Nyquist, 296
 Dual-Sine softkey, 175, 182, 189, 195
 Dummy Bearer 1 softkey, 607
 Dummy Bearer 2 softkey, 607
 Dummy softkey, 808
 DWCDMA softkey, 96
 Dwell Type List Step softkey, 51

E

Eb/No field, 1115
 Eb/No value (dB) field, 1085
 EbNo field, 512
 See CDMA2000 BBG subsystem keys and fields
 Ec/No value field, 1030, 1116
 EcNo field, 499, 534, 539
 EDGE BERT Off On softkey, 448
 EDGE EHSR softkey
 See dual ARB subsystem keys
 EDGE Off On softkey, 672
 EDGE softkey, 282, 283, 284, 641
 See dual ARB subsystem keys
 EDGE subsystem keys
 128QAM, 644
 16 1's & 16 0's, 637, 646, 648, 653
 16PSK, 644
 16QAM, 644
 256QAM, 644
 2-Lvl FSK, 644
 32 1's & 32 0's, 637, 646, 648, 653
 32QAM, 644
 4 1's & 4 0's, 637, 646, 648, 653
 4-Lvl FSK, 644
 4QAM, 644

Index

64 1's & 64 0's, [637](#), [646](#), [648](#), [653](#)
64QAM, [644](#)
8 1's & 8 0's, [637](#), [646](#), [648](#), [653](#)
8PSK, [644](#)
All Timeslots, [664](#)
APCO 25 C4FM, [641](#)
BBG Ref Ext Int, [640](#)
Begin Frame, [664](#)
Begin Timeslot #, [664](#), [665](#)
BPSK, [644](#)
Bus, [645](#), [669](#)
Continuous, [667](#)
CS-1, [648](#), [649](#)
CS-4, [648](#), [650](#)
Custom, [663](#)
Custom TS, [652](#), [662](#)
D8PSK, [644](#)
Data Format Pattern Framed, [636](#)
Downlink MCS-1, [648](#), [650](#)
Downlink MCS-5, [653](#)
Downlink MCS-9, [653](#)
EDGE, [641](#)
EDGE Off On, [672](#)
E-TCH/F43.2, [653](#)
Ext, [637](#), [645](#), [646](#), [653](#), [669](#)
Ext BBG Ref Freq, [640](#)
Ext Data Clock Ext Int, [629](#)
Ext Data Clock Normal Symbol, [639](#)
Ext Delay Bits, [670](#)
Ext Delay Off On, [671](#)
Ext Polarity Neg Pos, [671](#)
Fall Delay, [630](#), [631](#)
Fall Time, [632](#)
Filter Alpha, [629](#)
Filter BbT, [630](#)
FIX4, [637](#), [638](#), [646](#), [647](#), [648](#), [650](#), [653](#), [659](#)
Free Run, [667](#)
Freq Dev, [642](#)
G, [647](#), [661](#)
Gate Active Low High, [668](#)
Gated, [667](#)
Gaussian, [641](#)
GMSK, [663](#)
Gray Coded QPSK, [644](#)
I/Q Scaling, [642](#)
IS-95, [641](#)
IS-95 Mod, [641](#)
IS-95 Mod w/EQ, [641](#)
IS-95 OQPSK, [644](#)
IS-95 QPSK, [644](#)
IS-95 w/EQ, [641](#)
MSK, [644](#)
Multislot Off On, [653](#)
Normal, [663](#)
Normal All, [663](#)
Nyquist, [641](#)
Optimize FIR For EVM ACP, [637](#)
OQPSK, [644](#)
 $\pi/4$ DQPSK, [644](#)
Patt Trig In 1, [672](#)
Patt Trig In 2, [672](#)
Phase Dev, [643](#)
Phase Polarity Normal Invert, [644](#)
PN11, [637](#), [646](#), [653](#)
PN15, [637](#), [646](#), [648](#), [649](#), [650](#), [651](#), [653](#), [657](#), [658](#),
[659](#), [660](#)
PN20, [637](#), [646](#), [653](#)
PN23, [637](#), [646](#), [653](#)
PN9, [637](#), [646](#), [648](#), [649](#), [650](#), [651](#), [653](#), [657](#), [658](#),
[659](#), [660](#)
QPSK, [644](#)
Recall Secondary Frame State, [645](#)
Rectangle, [641](#)
Reset & Run, [667](#)
Restore EDGE Factory Default, [639](#)
Rise Delay, [633](#), [634](#)
Rise Time, [634](#), [635](#)
Root Nyquist, [641](#)
S, [652](#)
Save Secondary Frame State, [645](#)
Secondary Frame Off On, [646](#)
Sine, [636](#)
Single, [667](#)
Symbol Rate, [665](#)
Sync Out Offset, [664](#)
T1, [661](#)
T2, [662](#)
TCH/FS, [648](#), [651](#)
Timeslot Ampl Main Delta, [662](#)
Timeslot Off On, [663](#)

- Trigger & Run, [667](#)
- Trigger Key, [645](#), [669](#)
- TSC0, [652](#), [662](#)
- TSC1, [652](#), [662](#)
- TSC2, [652](#), [662](#)
- TSC3, [652](#), [662](#)
- TSC4, [652](#), [662](#)
- TSC5, [652](#), [662](#)
- TSC6, [652](#), [662](#)
- TSC7, [652](#), [662](#)
- UN3/4 GSM Gaussian, [641](#)
- Uncoded, [653](#)
- Uplink MCS-1, [648](#), [651](#)
- Uplink MCS-5, [653](#)
- Uplink MCS-9, [653](#)
- User File, [636](#), [637](#), [646](#), [648](#), [653](#)
- User FIR, [641](#)
- User FSK, [643](#), [644](#)
- User I/Q, [643](#), [644](#)
- edge subsystem keys
 - PRAM File, [638](#)
- EDGE Wide softkey
 - See* dual ARB subsystem keys
- Edit Channel Setup softkey, [252](#), [255](#)
- Edit Noise RMS Override softkey, [298](#)
- Edit Repetitions softkey, [317](#)
- Enter Secure Mode softkey, [162](#)
- Equal Energy per Symbol softkey, [366](#)
- Equal Powers softkey
 - See* CDMA ARB subsystem keys
 - See* CDMA2000 ARB subsystem keys
 - See* CDMA2000 BBG subsystem keys and fields
 - See* wideband CDMA base band generator subsystem keys and fields
- Erase All softkey, [161](#)
- Erase and Overwrite All softkey, [163](#)
- Erase and Sanitize All softkey, [163](#)
- Erase softkey, [161](#)
- ERROR
 - 221, [116](#)
- Error BER softkey, [1181](#)
- Error Bits softkey, [1174](#)
- Error Blocks field, [1175](#)
- Error Count softkey, [448](#)
 - See* sense subsystem keys
- Error Info softkey, [155](#)
- error messages, resolving, [676](#), [820](#)
- Error Out softkey, [419](#)
- Error Rate softkey
 - See* calculate subsystem keys
 - See* recalculate subsystem keys
- ESG file overview, [674](#), [818](#)
- ET softkey, [798](#)
- E-TCH/F43.2 softkey, [653](#)
- Even Second Delay, [486](#), [519](#)
- Exceeds Any Limit softkey, [411](#)
- Exceeds Any Thresholds softkey
 - See* sense subsystem keys
- Execute Cal softkey, [72](#), [73](#)
- Ext 50 Ohm softkey, [24](#), [35](#)
- Ext 600 Ohm softkey, [24](#), [35](#)
- Ext BBG Ref Freq softkey
 - See* custom subsystem keys
 - See* EDGE subsystem keys
 - See* GSM subsystem keys
 - See* NADC subsystem keys
 - See* PDC subsystem keys
 - See* PHS subsystem keys
 - See* TETRA subsystem keys
- Ext CDMA Freq field, [506](#)
- Ext Clock Rate x1 x2 x4 softkey, [1028](#)
- Ext Data Clock Ext Int softkey
 - See* EDGE subsystem keys
 - See* PDC subsystem keys
- Ext Data Clock Normal Symbol softkey
 - See* custom subsystem keys
 - See* DECT subsystem keys
 - See* EDGE subsystem keys
 - See* GSM subsystem keys
 - See* NADC subsystem keys
 - See* PDC subsystem keys
 - See* PHS subsystem keys
 - See* TETRA subsystem keys
- Ext Delay Bits softkey
 - See* custom subsystem keys
 - See* DECT subsystem keys
 - See* EDGE subsystem keys
 - See* GSM subsystem keys
 - See* NADC subsystem keys
 - See* PDC subsystem keys

Index

- See* PHS subsystem keys
 - See* TETRA subsystem keys
 - Ext Delay Off On softkey
 - See* CDMA ARB subsystem keys
 - See* CDMA2000 ARB subsystem keys
 - See* custom subsystem keys
 - See* DECT subsystem keys
 - See* Dmodulation subsystem keys
 - See* EDGE subsystem keys
 - See* GSM subsystem keys
 - See* NADC subsystem keys
 - See* PDC subsystem keys
 - See* PHS subsystem keys
 - See* TETRA subsystem keys
 - See* wideband CDMA ARB subsystem keys
 - Ext Delay Samples softkey, [325](#)
 - Ext Delay softkey, [325](#)
 - Ext Delay Time softkey, [236](#), [267](#), [291](#), [326](#), [381](#)
 - Ext Frame Trigger Delay softkey, [433](#)
 - Ext In 600 Ohm I Offset softkey, [27](#)
 - Ext In 600 Ohm Q Offset softkey, [28](#)
 - Ext Polarity Neg Pos softkey
 - See* CDMA ARB subsystem keys
 - See* CDMA2000 ARB subsystem keys
 - See* custom subsystem keys
 - See* DECT subsystem keys
 - See* Dmodulation subsystem keys
 - See* dual ARB subsystem keys
 - See* EDGE subsystem keys
 - See* GSM subsystem keys
 - See* NADC subsystem keys
 - See* PDC subsystem keys
 - See* PHS subsystem keys
 - See* TETRA subsystem keys
 - See* wideband CDMA ARB subsystem keys
 - Ext softkey
 - List/Sweep subsystem, [54](#)
 - See* amplitude modulation subsystem keys
 - See* CDMA ARB subsystem keys
 - See* CDMA2000 ARB subsystem keys
 - See* CDMA2000 BBG subsystem keys and fields
 - See* custom subsystem keys
 - See* DECT subsystem keys
 - See* Dmodulation subsystem keys
 - See* dual ARB subsystem keys
 - See* EDGE subsystem keys
 - See* frequency modulation subsystem keys
 - See* GSM subsystem keys
 - See* low frequency output subsystem keys
 - See* NADC subsystem keys
 - See* PDC subsystem keys
 - See* phase modulation subsystem keys
 - See* PHS subsystem keys
 - See* sense subsystem keys
 - See* TETRA subsystem keys
 - See* trigger subsystem keys
 - See* wideband CDMA ARB subsystem keys
 - See* wideband CDMA base band generator subsystem keys and fields
 - Ext softkeys
 - Ext Coupling DC AC, [173](#), [180](#), [193](#)
 - Ext Detector, [63](#)
 - Ext Pulse, [202](#)
 - Ext1, [176](#), [184](#), [196](#)
 - Ext2, [176](#), [184](#), [196](#)
 - extended numeric SCPI parameter, [8](#)
 - External Frame Trigger Polarity Neg Pos softkey, [433](#)
 - External softkey, [518](#)
- ## F
- FACC softkey
 - See* DECT subsystem keys
 - Fail Hold softkey, [411](#)
 - Fall Delay softkey
 - See* custom subsystem keys
 - See* DECT subsystem keys
 - See* EDGE subsystem keys
 - See* GSM subsystem keys
 - See* NADC subsystem keys
 - See* PDC subsystem keys
 - See* PHS subsystem keys
 - See* TETRA subsystem keys
 - Fall Time softkey
 - See* custom subsystem keys
 - See* DECT subsystem keys
 - See* EDGE subsystem keys
 - See* GSM subsystem keys
 - See* NADC subsystem keys
 - See* PDC subsystem keys

- See* PHS subsystem keys
 - See* TETRA subsystem keys
- Falling softkey, [553](#)
- FBI State field, [1091](#)
- FCDMA softkey, [96](#)
- FCOR softkey, [1006](#), [1011](#)
- FCorr softkey, [808](#)
- FDEV1_FS softkey
 - See* DECT subsystem keys
- FDEV1_HS softkey
 - See* DECT subsystem keys
- FDEV2_FS softkey
 - See* DECT subsystem keys
- Field 1 field, [496](#)
- Field 2 field, [496](#)
- Field 3 field, [497](#)
- file
 - names, [105](#)
 - retrieval, [116](#)
 - systems, [14](#)
 - types, [14](#)
- file overview, HDSPA, [818](#)
- file overview, HSPA, [674](#)
- Filter Alpha softkey, [1107](#)
 - See* CDMA ARB subsystem keys
 - See* CDMA2000 ARB subsystem keys
 - See* CDMA2000 BBG subsystem keys and fields
 - See* custom subsystem keys
 - See* DECT subsystem keys
 - See* Dmodulation subsystem keys
 - See* dual ARB subsystem keys
 - See* EDGE subsystem keys
 - See* GPS subsystem keys
 - See* GSM subsystem keys
 - See* NADC subsystem keys
 - See* PDC subsystem keys
 - See* PHS subsystem keys
 - See* TETRA subsystem keys
 - See* wideband CDMA ARB subsystem keys
 - See* wideband CDMA base band generator subsystem keys and fields
- Filter BbT softkey, [1108](#)
 - See* CDMA ARB subsystem keys
 - See* CDMA2000 ARB subsystem keys
 - See* CDMA2000 BBG subsystem keys and fields
- See* custom subsystem keys
 - See* DECT subsystem keys
 - See* Dmodulation subsystem keys
 - See* dual ARB subsystem keys
 - See* EDGE subsystem keys
 - See* GPS subsystem keys
 - See* GSM subsystem keys
 - See* NADC subsystem keys
 - See* PDC subsystem keys
 - See* PHS subsystem keys
 - See* TETRA subsystem keys
 - See* wideband CDMA ARB subsystem keys
 - See* wideband CDMA base band generator subsystem keys and fields
- FIR data, [108](#)
- FIR softkey, [97](#)
- First Mkr Point softkey, [304](#), [306](#)
- First Spread Code softkey, [361](#), [369](#)
- FIX softkey, [1091](#)
- FIX4 softkey, [650](#), [1090](#), [1119](#), [1123](#)
 - See* CDMA2000 BBG subsystem keys and fields
 - See* custom subsystem keys
 - See* DECT subsystem keys
 - See* EDGE subsystem keys
 - See* GPS subsystem keys
 - See* GSM subsystem keys
 - See* NADC subsystem keys
 - See* PDC subsystem keys
 - See* PHS subsystem keys
 - See* TETRA subsystem keys
 - See* wideband CDMA baseband generator subsystem keys and fields
- Flat Noise BW field, [1086](#)
- Flatness Off On softkey, [21](#)
- FM softkeys
 - FM Dev, [185](#)
 - FM Dev Couple Off On, [185](#)
 - FM Off On, [184](#)
 - FM Path 1 2, [179](#)
 - FM Stop Rate, [181](#)
 - FM Sweep Rate, [183](#)
 - FM Tone 2 Amp Percent of Peak, [182](#)
 - FM Tone 2 Rate, [181](#)
- forgiving listening and precise talking, [7](#)
- Frame Clock Polarity Neg Pos softkey, [1106](#)

Index

- Frame Count softkey
 - See* sense subsystem keys
- Frame Erasure softkey, 458
 - See* calculate subsystem keys
- Frame Length field
 - See* CDMA2000 BBG subsystem keys and fields
- Frame Offset field
 - See* CDMA2000 BBG subsystem keys and fields
- Frame offset field, 542
- Frame Polarity softkey, 393
- Frame Repeat Single Cont softkey, 897
- Frame Struct field, 1065
- Frame Sync Trigger Mode Single Cont softkey, 1161
- Frame Trigger Source Int Ext softkey, 434
- Free Run softkey
 - list trigger source, 54
 - See* amplitude modulation subsystem keys
 - See* CDMA ARB subsystem keys
 - See* CDMA2000 ARB subsystem keys
 - See* custom subsystem keys
 - See* DECT subsystem keys
 - See* Dmodulation subsystem keys
 - See* dual ARB subsystem keys
 - See* EDGE subsystem keys
 - See* frequency modulation subsystem keys
 - See* GSM subsystem keys
 - See* low frequency output subsystem keys
 - See* NADC subsystem keys
 - See* PDC subsystem keys
 - See* phase modulation subsystem keys
 - See* PHS subsystem keys
 - See* TETRA subsystem keys
 - See* trigger subsystem keys
 - See* wideband CDMA ARB subsystem keys
- Freq Dev softkey
 - See* custom subsystem keys
 - See* DECT subsystem keys
 - See* Dmodulation subsystem keys
 - See* EDGE subsystem keys
 - See* GSM subsystem keys
 - See* NADC subsystem keys
 - See* PDC subsystem keys
 - See* TETRA subsystem keys
- Freq softkeys
 - Freq, 42, 49
 - Freq & Ampl, 49
 - Freq Channels Off On, 41
 - Freq Drift Type Linear Sine, 476
 - Freq Multiplier, 42
 - Freq Offset, 43, 476
 - Freq Ref Off On, 44
 - Freq Ref Set, 43
 - Freq Spacing, 283, 340, 341
 - Freq Start, 44, 49
 - Freq Stop, 45, 49
- Frequency hardkey, 38, 41, 42, 45, 46
- frequency modulation subsystem keys
 - Bus, 183
 - Dual-Sine, 182
 - Ext, 183
 - Ext Coupling DC AC, 180
 - Ext1, 184
 - Ext2, 184
 - FM Dev, 185
 - FM Dev Couple Off On, 185
 - FM Off On, 184
 - FM Path 1 2, 179
 - FM Stop Rate, 181
 - FM Sweep Rate, 183
 - FM Tone 2 Amp Percent of Peak, 182
 - FM Tone 2 Rate, 181
 - Free Run, 183
 - Incr Set, 180
 - Internal 1, 184
 - Internal 2, 184
 - Noise, 182
 - Ramp, 182
 - Sine, 182
 - Square, 182
 - Swept-Sine, 182
 - Triangle, 182
 - Trigger Key, 183
- frequency subsystem keys
 - Adjust Phase, 47
 - Channel Number, 40
 - Freq, 42, 49
 - Freq Channels Off On, 41
 - Freq Multiplier, 42
 - Freq Offset, 43

- Freq Ref Off On, [44](#)
- Freq Ref Set, [43](#)
- Freq Start, [44](#), [49](#)
- Freq Stop, [45](#), [49](#)
- Frequency, [38](#), [41](#), [42](#), [45](#), [46](#)
- Off, [42](#), [49](#)
- Phase Ref Set, [47](#)
- Ref Oscillator Source Auto Off On, [48](#)
- FSK softkey, [97](#)
- FSYNCH Type field, [510](#)
- Full softkey, [535](#), [540](#)
- Function Generator softkey, [190](#)
- G**
- G softkey, [647](#), [661](#)
- Gain Unit dB Lin Index softkey, [371](#)
- Gate Active Low High softkey
 - See* CDMA ARB subsystem keys
 - See* CDMA2000 ARB subsystem keys
 - See* custom subsystem keys
 - See* DECT subsystem keys
 - See* Dmodulation subsystem keys
 - See* dual ARB subsystem keys
 - See* EDGE subsystem keys
 - See* GSM subsystem keys
 - See* NADC subsystem keys
 - See* PDC subsystem keys
 - See* PHS subsystem keys
 - See* TETRA subsystem keys
 - See* wideband CDMA ARB subsystem keys
- Gate Clk Delay softkey, [422](#)
- Gate Delay Off On softkey, [423](#)
- Gate Mode Time Clk softkey, [422](#)
- Gate Off On softkey, [424](#)
- Gate Polarity Neg Pos softkey, [424](#)
- Gate Time Delay softkey, [423](#)
- Gated softkey
 - See* CDMA ARB subsystem keys
 - See* CDMA2000 ARB subsystem keys
 - See* custom subsystem keys
 - See* DECT subsystem keys
 - See* Dmodulation subsystem keys
 - See* dual ARB subsystem keys
 - See* EDGE subsystem keys
 - See* GSM subsystem keys
- See* NADC subsystem keys
- See* PDC subsystem keys
- See* PHS subsystem keys
- See* TETRA subsystem keys
- See* wideband CDMA ARB subsystem keys
- Gaussian softkey
 - See* CDMA ARB subsystem keys
 - See* CDMA2000 ARB subsystem keys
 - See* CDMA2000 BBG subsystem keys and fields
 - See* custom subsystem keys
 - See* DECT subsystem keys
 - See* Dmodulation subsystem keys
 - See* dual ARB subsystem keys
 - See* EDGE subsystem keys
 - See* GPS subsystem keys
 - See* GSM subsystem keys
 - See* NADC subsystem keys
 - See* PDC subsystem keys
 - See* PHS subsystem keys
 - See* TETRA subsystem keys
 - See* wideband CDMA ARB subsystem keys
 - See* wideband CDMA base band generator subsystem keys and fields
- generate sine, [297](#)
- GMSK softkey, [663](#)
- Goto Row softkey, [338](#)
- GPIB Address softkey, [75](#)
- GPS Ref (f0) softkey, [774](#), [777](#)
- GPS Ref Clk Ext Int softkey, [774](#), [777](#)
- GPS subsystem
 - Data Mode Raw Enc TLM, [770](#)
- GPS subsystem keys
 - APCO 25 C4FM, [770](#)
 - Data Mode Raw Enc TLM, [769](#)
 - Doppler Shift, [770](#)
 - Filter Alpha, [771](#)
 - Filter BbT, [772](#)
 - FIX4, [769](#)
 - Gaussian, [770](#)
 - GPS Ref (f0), [774](#)
 - GPS Ref Clk Ext Int, [774](#)
 - IQ Phase Normal Invert, [773](#)
 - IS-95, [770](#)
 - IS-95 Mod, [770](#)
 - IS-95 Mod w/EQ, [770](#)

Index

- IS-95 w/EQ, [770](#)
- Nyquist, [770](#)
- Optimize FIR For EVM ACP, [772](#)
- P Code Pwr, [773](#)
- PN15, [769](#)
- PN9, [769](#)
- Ranging Code C/A P C/A+P, [773](#)
- Real-time GPS Off On, [775](#)
- Rectangle, [770](#)
- Root Nyquist, [770](#)
- Satellite ID, [775](#)
- UN3/4 GSM Gaussian, [770](#)
- User File, [769](#)
- User FIR, [770](#)
- Gray Coded QPSK softkey
 - See* custom subsystem keys
 - See* DECT subsystem keys
 - See* Dmodulation subsystem keys
 - See* EDGE subsystem keys
 - See* GSM subsystem keys
 - See* NADC subsystem keys
 - See* PDC subsystem keys
 - See* PHS subsystem keys
 - See* TETRA subsystem keys
- GSM BERT Off On softkey, [461](#)
- GSM Off On softkey, [817](#)
- GSM softkey, [282](#), [283](#), [284](#)
- GSM subsystem keys
 - 128QAM, [795](#)
 - 16 1's & 16 0's, [788](#), [797](#), [798](#), [800](#), [807](#)
 - 16PSK, [795](#)
 - 16QAM, [795](#)
 - 256QAM, [795](#)
 - 2-Lvl FSK, [795](#)
 - 32 1's & 32 0's, [788](#), [797](#), [798](#), [800](#), [807](#)
 - 32QAM, [795](#)
 - 4 1's & 4 0's, [788](#), [797](#), [798](#), [800](#), [807](#)
 - 4-Lvl FSK, [795](#)
 - 4QAM, [795](#)
 - 64 1's & 64 0's, [788](#), [797](#), [798](#), [800](#), [807](#)
 - 64QAM, [795](#)
 - 8 1's & 8 0's, [788](#), [797](#), [798](#), [800](#), [807](#)
 - 8PSK, [795](#)
 - Access, [808](#)
 - All Timeslots, [809](#)
 - APCO 25 C4FM, [792](#)
 - BBG Data Clock Ext Int, [779](#)
 - BBG Ref Ext Int, [791](#)
 - Begin Frame, [809](#)
 - Begin Timeslot #, [809](#), [810](#)
 - Bit Rate, [780](#)
 - BPSK, [795](#)
 - Bus, [796](#), [813](#)
 - Continuous, [812](#)
 - CS-1, [800](#)
 - CS-4, [804](#)
 - Custom, [808](#)
 - Custom TS, [799](#), [806](#)
 - D8PSK, [795](#)
 - Data Format Pattern Framed, [787](#)
 - Diff Data Encode Off On, [790](#)
 - Downlink MCS-1, [800](#)
 - Dummy, [808](#)
 - ET, [798](#)
 - Ext, [788](#), [796](#), [797](#), [798](#), [807](#), [813](#)
 - Ext BBG Ref Freq, [592](#), [791](#)
 - Ext Data Clock Normal Symbol, [790](#)
 - Ext Delay Bits, [814](#)
 - Ext Delay Off On, [815](#)
 - Ext Polarity Neg Pos, [815](#)
 - Fall Delay, [782](#), [783](#)
 - Fall Time, [782](#), [784](#)
 - FCorr, [808](#)
 - Filter Alpha, [779](#)
 - Filter BbT, [780](#)
 - FIX4, [788](#), [789](#), [797](#), [798](#), [799](#), [800](#), [805](#), [807](#), [808](#)
 - Free Run, [812](#)
 - Freq Dev, [793](#)
 - Gate Active Low High, [813](#)
 - Gated, [812](#)
 - Gaussian, [792](#)
 - Gray Coded QPSK, [795](#)
 - GSM Off On, [817](#)
 - I/Q Scaling, [793](#)
 - IS-95, [792](#)
 - IS-95 Mod, [792](#)
 - IS-95 Mod w/EQ, [792](#)
 - IS-95 OQPSK, [795](#)
 - IS-95 QPSK, [795](#)
 - IS-95 w/EQ, [792](#)

- MSK, 795
 - Multislot Off On, 799
 - Normal, 808
 - Normal All, 808
 - Nyquist, 792
 - Optimize FIR For EVM ACP, 788
 - OQPSK, 795
 - $\pi/4$ DQPSK, 795
 - Patt Trig In 1, 816
 - Patt Trig In 2, 816
 - Phase Dev, 794
 - Phase Polarity Normal Invert, 795
 - PN11, 788, 807
 - PN15, 788, 797, 798, 800, 804, 805, 807
 - PN20, 788, 807
 - PN23, 788, 807
 - PN9, 788, 797, 798, 800, 804, 805, 807
 - PN9 Mode Normal Quick, 781
 - QPSK, 795
 - Recall Secondary Frame State, 796
 - Rectangle, 792
 - Reset & Run, 812
 - Restore Factory Default, 789
 - Rise Delay, 784, 785
 - Rise Time, 786
 - Root Nyquist, 792
 - S, 806
 - Save Secondary Frame State, 796
 - Secondary Frame Off On, 797
 - Sine, 787
 - Single, 812
 - SS, 798
 - Symbol Rate, 810
 - Sync, 808
 - Sync Out Offset, 809
 - TCH/FS, 800
 - Timeslot Ampl Main Delta, 807
 - Timeslot Off On, 807
 - Trigger & Run, 812
 - Trigger Key, 796, 813
 - TS, 808
 - TSC0, 799, 806
 - TSC1, 799, 806
 - TSC2, 799, 806
 - TSC3, 799, 806
 - TSC4, 799, 806
 - TSC5, 799, 806
 - TSC6, 799, 806
 - TSC7, 799, 806
 - UN3/4 GSM Gaussian, 792
 - Uplink MCS-1, 800
 - User File, 787, 788, 797, 798, 800, 807
 - User FIR, 792
 - User FSK, 794, 795
 - User I/Q, 794, 795
 - gsm subsystem keys
 - PRAM Files, 789
 - guides, lxxi
- ## H
- Half softkey, 535, 540
 - Header field, 492, 502
 - Help Mode Single Cont softkey, 156
 - hexadecimal values, 18
 - High Amplitude softkey
 - See sense subsystem keys
 - High Crest Mode Off On softkey, 23
 - Higher Layer softkey, 1164
 - Hostname softkey, 76
 - HSDPA file overview, 818
 - HSDPA over W-CDMA SCPI commands, 818
 - HSDPA user files, 818
 - HSPA file overview, 674
 - HSPA user files, 674
- ## I
- I Gain softkey, 391
 - I Offset softkey, 29, 392
 - I/Q Adjustments Off On softkey, 32
 - I/Q Calibration softkey, 72
 - I/Q Gain Balance Source 1 softkey, 29
 - I/Q Mapping Normal Invert softkey, 221, 247, 349
 - I/Q Mod Filter Manual Auto softkey, 33, 208, 222, 246, 275, 304, 333, 351, 480
 - I/Q Off On softkey, 37
 - I/Q Out Gain Balance softkey, 27
 - I/Q Output Atten softkey, 28
 - I/Q Output Filter Manual Auto softkey, 206, 217, 242, 270, 301, 302, 331, 349, 472

Index

- I/Q Scaling softkey
 - See* custom subsystem keys
 - See* DECT subsystem keys
 - See* EDGE subsystem keys
 - See* GSM subsystem keys
 - See* NADC subsystem keys
 - See* PDC subsystem keys
 - See* PHS subsystem keys
 - See* TETRA subsystem keys
- I/Q softkey, 98
- I/Q Timing Skew Path, 32
- I/Q timing Skew softkey, 31
- IDLE softkey, 961, 980
- IEEE 488.2 common command keys
 - Diagnostic Info, 89
 - Instrument Options, 90
 - RECALL Reg, 90
 - Run Complete Self Test, 92
 - Save Reg, 91
 - Save Seq[n] Reg[nn], 91
 - Select Seq, 90
- Immediate softkey, 227, 261, 281, 315
 - See* sense subsystem keys
- Impairments Off On softkey, 473
- Impedance 75 Ohm High softkey, 426
- Incr Set hardkey, 69
 - See* amplitude modulation subsystem keys
 - See* frequency modulation subsystem keys
 - See* phase modulation subsystem keys
- Increment Scramble Code softkey, 357
- Increment Timing Offset softkey, 360
- Infinity softkey, 1068, 1166
- Init Power field, 1110
- Init Pwr field, 1128, 1143
- Initial Bit Count softkey, 447
- Initial Block Count softkey, 437, 440
- Initial Frame Count softkey, 457
- Initialize Phase Fixed Random softkey, 342
- Initialize Table softkey, 284
- input subsystem keys
 - 0.7V, 427
 - 1.4V, 427
 - 1.6V, 427
 - 2.5V, 427
 - Clock Delay Off On, 425
 - Clock Polarity Neg Pos, 426
 - Clock Time Delay, 425
 - Data Polarity Neg Pos, 426
 - Gate Clk Delay, 422
 - Gate Delay Off On, 423
 - Gate Mode Time Clk, 422
 - Gate Off On, 424
 - Gate Polarity Neg Pos, 424
 - Gate Time Delay, 423
 - Impedance 75 Ohm High, 426
 - Resolution, 424
- Insert Row softkey, 249, 252, 255, 284
- Insert Waveform softkey, 317
- installation guide, lxxi
- Installed Board Info softkey, 81
- Instrument Options softkey, 90
- Int I/Q Skew Corrections RF BB Off softkey, 35
- Int softkeys
 - Int Doublet, 202
 - Int Free-Run, 202
 - Int Gated, 202
 - Int Phase Polarity Normal Invert, 24, 34
 - Int Triggered, 202
- integer response data, 11
- Intermod softkey, 1072
- Internal softkeys
 - Internal, 63, 176, 518
 - Internal 1, 184, 196
 - Internal 2, 184, 196
 - Internal Monitor, 190
 - Internal Square, 202
- Inverse Video Off On softkey, 87
- Inverted softkey, 523
- IP address, 75
- IP Address softkey, 76
- IQ Phase Normal Invert softkey, 773, 776
- IQ Polarity softkey, 394
- IS-2000 SR3 DS softkey
 - See* CDMA ARB subsystem keys
 - See* CDMA2000 ARB subsystem keys
 - See* Dmodulation subsystem keys
 - See* wideband CDMA ARB subsystem keys
- IS-95 Mod softkey
 - See* CDMA ARB subsystem keys
 - See* CDMA2000 ARB subsystem keys

- See* CDMA2000 BBG subsystem keys and fields
- See* custom subsystem keys
- See* DECT subsystem keys
- See* Dmodulation subsystem keys
- See* dual ARB subsystem keys
- See* EDGE subsystem keys
- See* GPS subsystem keys
- See* GSM subsystem keys
- See* NADC subsystem keys
- See* PDC subsystem keys
- See* PHS subsystem keys
- See* TETRA subsystem keys
- See* wideband CDMA ARB subsystem keys
- See* wideband CDMA base band subsystem keys and fields
- IS-95 Mod w/EQ softkey
 - See* CDMA ARB subsystem keys
 - See* CDMA2000 ARB subsystem keys
 - See* CDMA2000 BBG subsystem keys and fields
 - See* custom subsystem keys
 - See* DECT subsystem keys
 - See* Dmodulation subsystem keys
 - See* dual ARB subsystem keys
 - See* EDGE subsystem keys
 - See* GPS subsystem keys
 - See* GSM subsystem keys
 - See* NADC subsystem keys
 - See* PDC subsystem keys
 - See* PHS subsystem keys
 - See* TETRA subsystem keys
 - See* wideband CDMA ARB subsystem keys
 - See* wideband CDMA base band generator subsystem keys and fields
- IS-95 OQPSK softkey
 - See* custom subsystem keys
 - See* DECT subsystem keys
 - See* Dmodulation subsystem keys
 - See* EDGE subsystem keys
 - See* GSM subsystem keys
 - See* NADC subsystem keys
 - See* PDC subsystem keys
 - See* PHS subsystem keys
 - See* TETRA subsystem keys
- IS-95 QPSK softkey
 - See* custom subsystem keys
- See* DECT subsystem keys
- See* Dmodulation subsystem keys
- See* EDGE subsystem keys
- See* GPS subsystem keys
- See* GSM subsystem keys
- See* NADC subsystem keys
- See* PDC subsystem keys
- See* PHS subsystem keys
- See* TETRA subsystem keys
- See* wideband CDMA ARB subsystem keys
- IS-97 Levels softkey, 229

Index

- J**
jy, 942
- L**
LAN Config softkey, 75
Last Mkr Point softkey, 304, 306
Leap Seconds field, 507
Left Alternate softkey, 361
Left softkey, 1034
LF Out softkeys
 LF Out Amplitude, 186
 LF Out Off On, 190
 LF Out Stop Freq, 186, 187, 193
 LF Out Sweep Rate, 188
 LF Out Sweep Time, 189
 LF Out Tone 2 Ampl % of Peak, 187
 LF Out Tone 2 Freq, 186, 187, 193
Link Down Up softkey, 351, 1083
Link Forward Reverse softkey, 247, 485
list data, 114
List softkey, 98, 124
list/sweep subsystem keys
 # Points, 57
 Ampl, 49, 66
 Ampl Start, 49, 67
 Ampl Stop, 49, 68
 Dwell Type List Step, 51
 Freq, 42, 49
 Freq & Ampl, 49
 Freq Start, 44, 49
 Freq Stop, 45, 49
 Load List From Step Sweep, 55
 Manual Mode Off On, 53
 Manual Point, 52
 Off, 42, 49, 66
 Preset List, 56
 Step Dwell, 56
 Sweep Direction Down Up, 50
 Sweep Retrace Off On, 54
 Sweep Type List Step, 55
Load From Selected File softkey, 20, 123, 127, 340
Load List From Step Sweep softkey, 55
Load/Store softkey, 284
Logic Type softkey, 399
Long Code Mask field, 522
Long Code State field, 489, 522
Loop Back Test Type softkey, 399
Low Amplitude softkey, 436, 439
 See sense subsystem keys
Low Capacity softkey, 596, 607
Low Capacity with Z field softkey, 596, 607
low frequency output subsystem keys
 Bus, 189
 DC, 189
 Dual-Sine, 189
 Ext, 189
 Free Run, 189
 Function Generator, 190
 Internal Monitor, 190
 LF Out Amplitude, 186
 LF Out Off On, 190
 LF Out Stop Freq, 186, 187, 193
 LF Out Sweep Rate, 188
 LF Out Sweep Time, 189
 LF Out Tone 2 Ampl % of Peak, 187
 LF Out Tone 2 Freq, 186, 187, 193
 Noise, 189
 Ramp, 189
 Sine, 189
 Square, 189
 Swept-Sine, 189
 Triangle, 189
 Trigger Key, 189
LTM OFF field, 507
- M**
Manual Mode Off On softkey, 53
Manual Point softkey, 52
Marker 1 2 3 4 softkey, 306
Marker 1 Polarity Neg Pos softkey, 212, 226, 260, 280, 481
 dual ARB subsystem, 312, 337, 481
 wideband CDMA ARB subsystem, 375
Marker 1 softkey, 209, 210, 222, 223, 224, 257, 258, 276, 277, 309, 333, 334, 335, 372, 373, 480, 481
 dual ARB subsystem, 310
Marker 2 Polarity Neg Pos softkey, 212, 226, 260, 280, 482
 dual ARB subsystem, 312, 337, 375, 481

- Marker 2 softkey, [209](#), [210](#), [222](#), [223](#), [224](#), [257](#), [258](#), [276](#), [277](#), [309](#), [333](#), [334](#), [335](#), [372](#), [373](#), [480](#), [481](#)
 - dual ARB subsystem, [310](#)
- Marker 3 Polarity Neg Pos softkey, [212](#), [226](#), [260](#), [280](#), [482](#)
 - dual ARB subsystem, [312](#), [337](#), [481](#)
 - wideband CDMA ARB subsystem, [375](#)
- Marker 3 softkey, [209](#), [210](#), [222](#), [223](#), [224](#), [257](#), [258](#), [276](#), [277](#), [309](#), [333](#), [334](#), [335](#), [372](#), [373](#), [480](#), [481](#)
 - dual ARB subsystem, [310](#)
- Marker 4 Polarity Neg Pos softkey, [212](#), [226](#), [260](#), [280](#), [482](#)
 - dual ARB subsystem, [312](#), [337](#), [481](#)
 - wideband CDMA ARB subsystem, [375](#)
- Marker 4 softkey, [209](#), [210](#), [222](#), [223](#), [224](#), [257](#), [258](#), [276](#), [277](#), [309](#), [333](#), [334](#), [335](#), [372](#), [373](#), [480](#), [481](#)
 - dual ARB subsystem, [310](#)
- marker polarity, [212](#)
- Marker softkey, [304](#)
- Markers, [304](#)
- markers
 - alc hold
 - AWGN subsystem, [209](#)
 - CDMA ARB subsystem, [223](#)
 - CDMA2000 ARB subsystem, [257](#)
 - Dmodulation subsystem, [276](#)
 - dual ARB subsystem, [309](#)
 - multitone subsystem, [334](#), [335](#)
 - wideband CDMA ARB subsystem, [372](#)
 - alternate amplitude
 - AWGN subsystem, [209](#)
 - CDMA ARB subsystem, [222](#)
 - CDMA2000 ARB subsystem, [257](#)
 - Dmodulation subsystem, [276](#)
 - dual ARB subsystem, [309](#)
 - multitone subsystem, [333](#)
 - wideband CDMA ARB subsystem, [372](#)
 - clearing, [304](#)
 - marker polarity
 - CDMA ARB subsystem, [226](#)
 - CDMA2000 ARB subsystem, [260](#)
 - Dmodulation subsystem, [280](#)
 - dual ARB subsystem, [312](#), [481](#)
 - multitone subsystem, [337](#)
 - wideband CDMA ARB subsystem, [375](#)
 - polarity
 - AWGN subsystem, [212](#)
 - RF blanking/pulse
 - AWGN subsystem, [210](#)
 - CDMA ARB subsystem, [224](#)
 - CDMA2000 ARB subsystem, [258](#)
 - Demodulation subsystem, [277](#)
 - dual ARB subsystem, [310](#)
 - wideband CDMA ARB subsystem, [373](#)
 - setting, [306](#)
 - shifting points, [306](#)
- mass memory subsystem keys
 - Binary, [124](#)
 - Copy File, [124](#)
 - Delete All NVWFM Files, [125](#)
 - Delete All WFM Files, [125](#)
 - Delete All WFM1 Files, [125](#)
 - Delete File, [126](#)
 - List, [124](#)
 - Load From Selected File, [127](#)
 - Rename File, [127](#)
 - State, [124](#)
 - Store To File, [127](#)
 - User Flatness, [124](#)
- Max Input softkey, [1072](#)
- Max Power field, [1111](#)
- Max Pwr field, [1129](#), [1144](#)
- MCDMA softkey, [99](#)
- MDMOD softkey, [99](#)
- MDWCDMA softkey, [100](#)
- Measurement Mode BER% Search softkey, [456](#)
- Measurement Mode BLER% Search softkey, [442](#)
- memory subsystem, [107](#), [109](#), [110](#)
- memory subsystem keys, [113](#), [115](#)
 - Add Comment To Seq[n] Reg[nn], [123](#)
 - All, [104](#), [122](#)
 - Binary, [94](#)
 - Bit, [94](#)
 - CDMA, [95](#)
 - Copy File, [105](#), [114](#)
 - Data PRAM, [112](#)
 - Delete All ARB CDMA Files, [118](#)
 - Delete All ARB DMOD Files, [118](#)
 - Delete All ARB DWCDMA Files, [119](#)
 - Delete All ARB FCDMA Files, [119](#)

Index

- Delete All ARB MCDMA Files, [120](#)
- Delete All ARB MDWCDMA Files, [120](#)
- Delete All ARB MTONE Files, [121](#)
- Delete All ARB RCDMA Files, [121](#)
- Delete All ARB UWCDMA Files, [122](#)
- Delete All Binary Files, [118](#)
- Delete All Bit Files, [118](#)
- Delete All Files, [117](#)
- Delete All FIR Files, [119](#)
- Delete All FSK Files, [119](#)
- Delete All I/Q Files, [119](#)
- Delete All List Files, [120](#)
- Delete All MDMOD Files, [120](#)
- Delete All MFCDMA Files, [120](#)
- Delete All SEQ Files, [121](#)
- Delete All SHAPE Files, [121](#)
- Delete All State Files, [121](#)
- Delete All UFLT Files, [122](#)
- Delete File, [122](#)
- DMOD, [95](#)
- DWCDMA, [96](#)
- FCDMA, [96](#)
- FIR, [97](#)
- FSK, [97](#)
- I/Q, [98](#)
- List, [98](#)
- Load From Selected File, [123](#)
- MCDMA, [99](#)
- MDMOD, [99](#)
- MDWCDMA, [100](#)
- MFCDMA, [100](#)
- MTONE, [101](#)
- Oversample Ratio, [108](#)
- RCDMA, [101](#)
- Rename File, [123](#)
- SEQ, [102](#)
- SHAPE, [102](#)
- State, [103](#)
- Store To File, [123](#)
- User Flatness, [103](#)
- UWCDMA, [104](#)
- Message Data Raw Data (RPS11) softkey
 - See* wideband CDMA base band generator
 - subsystem keys and fields
- Message Part field, [1127](#)
- Message Pulse (RPS22) softkey
 - See* wideband CDMA base band generator
 - subsystem keys and fields
- Message Type field, [508](#)
- Message-Control Raw Data Clock (RPS12) softkey
 - See* wideband CDMA base band generator
 - subsystem keys and fields
- Meter Address softkeys, [77](#)
- Meter Channel A B softkey, [77](#)
- Meter Timeout softkey, [78](#)
- MFCDMA softkey, [100](#)
- Min Power field, [1111](#)
- Mod Index softkey, [477](#)
- Mod On/Off hardkey, [129](#)
- Modulation Filter Off On softkey, [297](#)
- Modulator Atten Manual Auto softkey, [33](#), [34](#), [207](#), [221](#), [245](#), [246](#), [274](#), [302](#), [303](#), [332](#), [350](#), [478](#), [479](#)
- Msg Ctrl softkey, [1116](#)
- Msg Data softkey, [1116](#)
- Msg Pwr field, [1127](#), [1142](#)
- MSGPS subsystem keys
 - GPS Ref (f0), [777](#)
 - GPS Ref Clk Ext Int, [777](#)
 - IQ Phase Normal Invert, [776](#)
 - Number of Satellites, [778](#)
 - Pause/Resume, [776](#)
 - Real-time MSGPS Off On, [778](#)
 - Restart, [777](#)
 - Scenario, [778](#)
 - Select Scenario, [778](#)
- MSK softkey
 - See* custom subsystem keys
 - See* DECT subsystem keys
 - See* Dmodulation subsystem keys
 - See* EDGE subsystem keys
 - See* GSM subsystem keys
 - See* NADC subsystem keys
 - See* PDC subsystem keys
 - See* PHS subsystem keys
 - See* TETRA subsystem keys
- MTONE softkey, [101](#)
- multicarrier, [352](#)
- Multicarrier Off On softkey, [228](#), [247](#), [282](#)
- Multicarrier softkey, [352](#)
- Multislot Off On softkey, [653](#), [799](#)

- Multitone Off On softkey, 343
- multitone subsystem keys
 - 2.100 MHz, 333
 - 40.000 MHz, 331, 333
 - ARB Reference Ext Int, 337
 - ARB Sample Clock, 339
 - Clear Header, 330
 - Freq Spacing, 340, 341
 - Goto Row, 338
 - I/Q Mod Filter Manual Auto, 333
 - I/Q Output Filter Manual Auto, 331
 - Initialize Phase Fixed Random, 342
 - Load From Selected File, 340
 - Marker 1, 333, 334, 335
 - Marker 2, 333, 334, 335
 - Marker 3, 333, 334, 335
 - Marker 4, 333, 334, 335
 - Modulator Atten Manual Auto, 332
 - Multitone Off On, 343
 - None, 333, 334, 335
 - Number Of Tones, 340, 341
 - Random Seed Fixed Random, 342
 - Reference Freq, 337
 - Save Setup To Header, 330
 - Store To File, 340
 - Through, 331, 333
 - Toggle State, 338, 340
 - Waveform Runtime Scaling, 339
- mV softkey, 170
- mVemf softkey, 170
- N**
- N Power field, 1087, 1117
- N5102A, 386
 - See* digital subsystem
- N5102A Off On softkey, 401
- NADC Off On softkey, 914
- NADC softkey, 282, 283, 284
- NADC subsystem keys
 - 128QAM, 896
 - 16 1's & 16 0's, 890, 899, 901, 903, 904
 - 16PSK, 896
 - 16QAM, 896
 - 256QAM, 896
 - 2-Lvl FSK, 896
 - 32 1's & 32 0's, 890, 899, 901, 903, 904
 - 32QAM, 896
 - 4 1's & 4 0's, 890, 899, 901, 903, 904
 - 4-Lvl FSK, 896
 - 4QAM, 896
 - 64 1's & 64 0's, 890, 899, 901, 903, 904
 - 64QAM, 896
 - 8 1's & 8 0's, 890, 899, 901, 903, 904
 - 8PSK, 896
 - All Timeslots, 906
 - APCO 25 C4FM, 893
 - BBG Data Clock Ext Int, 880
 - BBG Ref Ext Int, 892
 - Begin Frame, 906
 - Begin Timeslot #, 906, 907
 - Bit Rate, 881
 - BPSK, 896
 - Bus, 898, 910
 - CDL, 900
 - CDVCC, 900, 903
 - Continuous, 908
 - D8PSK, 896
 - Data Format Pattern Framed, 888
 - Down Custom, 905
 - Down TCH, 905
 - Down TCH All, 905
 - Ext, 890, 898, 899, 901, 903, 904, 910
 - Ext BBG Ref Freq, 893
 - Ext Data Clock Normal Symbol, 892
 - Ext Delay Bits, 911
 - Ext Delay Off On, 912
 - Ext Polarity Neg Pos, 912
 - Fall Delay, 883, 884
 - Fall Time, 884, 885
 - Filter Alpha, 880
 - Filter BbT, 881
 - FIX4, 890, 891, 899, 901, 902, 903, 904, 905
 - Frame Repeat Single Cont, 897
 - Free Run, 909
 - Freq Dev, 895
 - Gate Active Low High, 910
 - Gated, 908
 - Gaussian, 893
 - Gray Coded QPSK, 896
 - I/Q Scaling, 894

Index

IS-95, [893](#)
IS-95 Mod, [893](#)
IS-95 Mod w/EQ, [893](#)
IS-95 OQPSK, [896](#)
IS-95 QPSK, [896](#)
IS-95 w/EQ, [893](#)
MSK, [896](#)
NADC Off On, [914](#)
Nyquist, [893](#)
Optimize FIR For EVM ACP, [889](#)
OQPSK, [896](#)
 $\pi/4$ DQPSK, [896](#)
Patt Trig In 1, [912](#)
Patt Trig In 2, [912](#)
Phase Dev, [895](#)
PN11, [890](#), [899](#), [901](#), [903](#), [904](#)
PN15, [890](#), [899](#), [901](#), [903](#), [904](#)
PN20, [890](#), [899](#), [901](#), [903](#), [904](#)
PN23, [890](#), [899](#), [901](#), [903](#), [904](#)
PN9, [890](#), [899](#), [901](#), [903](#), [904](#)
PN9 Mode Normal Quick, [882](#)
Polarity Normal Invert, [897](#)
QPSK, [896](#)
Rate Full Half, [894](#)
Recall Secondary Frame State, [897](#)
Rectangle, [893](#)
Reset & Run, [909](#)
Restore NADC Factory Default, [891](#)
Rise Delay, [886](#)
Rise Time, [887](#), [888](#)
Root Nyquist, [893](#)
SACCH, [900](#), [904](#)
Save Secondary Frame State, [898](#)
Secondary Frame Off On, [898](#)
Sine, [883](#), [889](#)
Single, [908](#)
Symbol Rate, [907](#)
SYNC, [901](#), [904](#)
Sync Out Offset, [906](#)
Timeslot Ampl Main Delta, [902](#)
Timeslot Off On, [902](#)
Trigger & Run, [909](#)
Trigger Key, [898](#), [910](#)
UN3/4 GSM Gaussian, [893](#)
Up Custom, [905](#)
Up TCH, [905](#)
Up TCH All, [905](#)
User File, [883](#), [889](#), [890](#), [899](#), [901](#), [903](#), [904](#)
User FIR, [893](#)
User FSK, [895](#), [896](#)
User I/Q, [896](#)
nadc subsystem keys
 PRAM Files, [890](#)
Name and Store softkey, [317](#)
Negate I softkey, [392](#)
Negate Q softkey, [395](#)
Network ID field, [508](#)
No Limits softkey
 See calculate subsystem keys
No Thresholds softkey
 See sense subsystem keys
Noise Bandwidth Factor softkey, [312](#)
Noise Off On softkey, [512](#), [524](#)
Noise Seed Fixed Random softkey, [214](#)
Noise Seed softkey, [475](#)
Noise softkey, [175](#), [182](#), [189](#), [195](#)
NONE (RPS0) softkey
 See wideband CDMA base band generator
 subsystem keys and fields
NONE softkey, [1172](#)
None softkey, [161](#), [209](#), [210](#), [222](#), [223](#), [224](#), [257](#),
 [258](#), [276](#), [277](#), [309](#), [310](#), [333](#), [334](#), [335](#), [372](#),
 [373](#), [480](#), [481](#), [573](#), [1076](#), [1078](#), [1177](#), [1184](#)
Normal All softkey, [663](#), [808](#)
Normal softkey, [523](#), [663](#), [808](#), [1034](#)
Num of Blk field, [1178](#), [1185](#)
Num of Pre field, [1128](#), [1143](#)
Number of AICH field, [1113](#)
Number of PRACH 80ms field, [1127](#)
Number of PRACH field, [1140](#), [1142](#)
Number of Preamble field, [1143](#)
Number of Satellites softkey, [778](#)
Number Of Tones softkey, [340](#), [341](#)
numeric boolean response data, [11](#)
Numeric Format, [393](#)
Numeric Format softkey, [393](#)
numeric SCPI parameter, [8](#)
numeric, extended SCPI parameter, [8](#)
Nyquist softkey
 See CDMA ARB subsystem keys

- See* CDMA2000 ARB subsystem keys
 - See* CDMA2000 BBG subsystem keys and fields
 - See* custom subsystem keys
 - See* DECT subsystem keys
 - See* Dmodulation subsystem keys
 - See* dual ARB subsystem keys
 - See* EDGE subsystem keys
 - See* GPS subsystem keys
 - See* GSM subsystem keys
 - See* NADC subsystem keys
 - See* PDC subsystem keys
 - See* PHS subsystem keys
 - See* TETRA subsystem keys
 - See* wideband CDMA ARB subsystem keys
 - See* wideband CDMA base band generator subsystem keys and fields
- O**
- OCNS softkey, [362](#)
 - octal values, [18](#)
 - Off softkey, [24](#), [35](#), [42](#), [49](#), [66](#), [227](#), [261](#), [281](#), [315](#), [1139](#)
 - Off softkey, dual ARB trigger delay, [325](#)
 - Omitted softkey, [1068](#), [1166](#)
 - On softkey, [227](#), [261](#), [281](#), [315](#), [1139](#)
 - On/Off field, [1050](#), [1132](#)
 - OpenLoop Ant1 SCH TSTD OFF softkey, [1073](#)
 - OpenLoop Ant1 softkey, [1073](#)
 - OpenLoop Ant2 SCH TSTD OFF softkey, [1073](#)
 - OpenLoop Ant2 softkey, [1073](#)
 - Optimize ACP ADJ ALT softkey, [351](#), [367](#)
 - Optimize FIR For EVM ACP softkey, [1108](#)
 - See* CDMA ARB subsystem keys
 - See* CDMA2000 ARB subsystem keys
 - See* CDMA2000 BBG subsystem keys and fields
 - See* custom subsystem keys
 - See* DECT subsystem keys
 - See* Dmodulation subsystem keys
 - See* dual ARB subsystem keys
 - See* EDGE subsystem keys
 - See* GPS subsystem keys
 - See* GSM subsystem keys
 - See* NADC subsystem keys
 - See* PDC subsystem keys
 - See* PHS subsystem keys
 - See* TETRA subsystem keys
 - See* wideband CDMA ARB subsystem keys
 - See* wideband CDMA base band generator subsystem keys and fields
- options
- 001/002
 - all subsystem, [204](#), [468](#)
 - custom subsystem, [554](#)
 - Dmodulation subsystem, [270](#)
 - dual ARB subsystem, [294](#)
 - multitone subsystem, [330](#)
 - 400
 - wideband CDMA ARB subsystem, [344](#)
 - wideband CDMA base band generator subsystem, [1028](#)
 - 401
 - CDMA ARB subsystem, [215](#)
 - CDMA2000 ARB subsystem, [240](#)
 - CDMA2000 BBG subsystem, [485](#)
 - 402
 - DECT subsystem, [580](#)
 - EDGE subsystem, [629](#)
 - GSM subsystem, [779](#)
 - NADC subsystem, [880](#)
 - PDC subsystem, [915](#)
 - PHS subsystem, [948](#)
 - TETRA subsystem, [984](#)
 - 403
 - AWGN real-time subsystem, [469](#)
 - AWGN subsystem, [205](#)
 - 406
 - bluetooth subsystem, [470](#)
 - 409
 - GPS subsystem, [769](#)
 - 424
 - GPS subsystem, [769](#)
 - MSGPS subsystem, [776](#)
 - UN7/300
 - calculate subsystem, [404](#)
 - data subsystem, [414](#)
 - input subsystem, [422](#), [428](#)
 - sense subsystem, [431](#)
- Options Info softkey, [83](#)
- OQPSK softkey
- See* custom subsystem keys

Index

- See* DECT subsystem keys
 - See* Dmodulation subsystem keys
 - See* EDGE subsystem keys
 - See* GSM subsystem keys
 - See* NADC subsystem keys
 - See* PDC subsystem keys
 - See* PHS subsystem keys
 - See* TETRA subsystem keys
 - Output Blanking Off On Auto softkey, [128](#)
 - output subsystem keys
 - Mod On/Off, [129](#)
 - Output Blanking Off On Auto, [128](#)
 - RF On/Off, [129](#)
 - Oversample Ratio softkey, [108](#), [226](#)
 - Overwrite softkey, [161](#)
 - P**
 - P Code Pwr softkey, [773](#)
 - P Rev field, [509](#)
 - P Rev Min field, [507](#)
 - P softkey, [598](#)
 - $\pi/4$ DQPSK softkey
 - See* custom subsystem keys
 - See* DECT subsystem keys
 - See* Dmodulation subsystem keys
 - See* EDGE subsystem keys
 - See* GSM subsystem keys
 - See* NADC subsystem keys
 - See* PDC subsystem keys
 - See* PHS subsystem keys
 - See* TETRA subsystem keys
 - Packet (DH1) softkey, [482](#)
 - Paging Indicator field, [516](#), [1054](#)
 - Paging softkey, [229](#)
 - parameter types. *See* SCPI commands parameter types
 - Pass Amplitude softkey, [436](#), [440](#)
 - See* sense subsystem keys
 - Pass Through Preset softkey, [401](#)
 - Pass/Fail Limits softkey, [412](#)
 - Pass/Fail Off On softkey, [412](#)
 - paths, SCPI command tree, [7](#)
 - Patt Trig In 1 softkey
 - See* CDMA ARB subsystem keys
 - See* CDMA2000 ARB subsystem keys
 - See* custom subsystem keys
 - See* DECT subsystem keys
 - See* Dmodulation subsystem keys
 - See* dual ARB subsystem keys
 - See* EDGE subsystem keys
 - See* GSM subsystem keys
 - See* NADC subsystem keys
 - See* PDC subsystem keys
 - See* PHS subsystem keys
 - See* TETRA subsystem keys
 - See* wideband CDMA ARB subsystem keys
- Patt Trig In 2 softkey
 - See* CDMA ARB subsystem keys
 - See* CDMA2000 ARB subsystem keys
 - See* custom subsystem keys
 - See* DECT subsystem keys
 - See* Dmodulation subsystem keys
 - See* dual ARB subsystem keys
 - See* EDGE subsystem keys
 - See* GSM subsystem keys
 - See* NADC subsystem keys
 - See* PDC subsystem keys
 - See* PHS subsystem keys
 - See* TETRA subsystem keys
 - See* wideband CDMA ARB subsystem keys
- Pattern trigger in 1 field, [1153](#)
 - Pattern trigger in 2 field, [1154](#)
 - Pause/Resume softkey, [776](#)
 - PCCPCH + SCH + 3 DPCH softkey, [352](#), [358](#)
 - PCCPCH + SCH +1 DPCH softkey, [352](#), [358](#)
 - PCCPCH + SCH softkey, [352](#), [358](#)
 - P-CCPCH data (DRPS39) softkey, [1058](#), [1060](#), [1061](#), [1062](#), [1063](#)
 - P-CCPCH data-clk (DRPS38) softkey, [1058](#), [1060](#), [1061](#), [1062](#), [1063](#)
 - PCCPCH softkey, [1030](#), [1031](#)
 - PDC Off On softkey, [947](#)
 - PDC softkey, [282](#), [283](#), [284](#)
 - PDC subsystem keys
 - 128QAM, [930](#)
 - 16 1's & 16 0's, [924](#), [933](#), [934](#), [936](#), [938](#)
 - 16PSK, [930](#)
 - 16QAM, [930](#)

256QAM, 930
2-Lvl FSK, 930
32 1's & 32 0's, 924, 933, 934, 936, 938
32QAM, 930
4 1's & 4 0's, 924, 933, 934, 936, 938
4-Lvl FSK, 930
4QAM, 930
64 1's & 64 0's, 924, 933, 934, 936, 938
64QAM, 930
8 1's & 8 0's, 924, 933, 934, 936, 938
8PSK, 930
All Timeslots, 940
APCO 25 C4FM, 927
BBG Ref Ext Int, 926
Begin Frame, 940
Begin Timeslot #, 940, 941
Bit Rate, 916
BPSK, 930
Bus, 932, 944
CC, 933, 937, 939
Continuous, 943
D8PSK, 930
Data Format Pattern Framed, 923
Down Custom, 940
Down TCH, 940
Down TCH All, 940
Ext, 924, 932, 933, 934, 936, 938, 944
Ext BBG Ref Freq, 927
Ext Data Clock Ext Int, 915
Ext Data Clock Normal Symbol, 926
Ext Delay Bits, 945
Ext Delay Off On, 946
Ext Polarity Neg Pos, 946
Fall Delay, 918, 919
Fall Time, 918, 920
Filter Alpha, 915
Filter BbT, 916
FIX4, 924, 925, 933, 934, 935, 936, 938
Free Run, 943
Freq Dev, 929
Gate Active Low High, 944
Gated, 943
Gaussian, 927
Gray Coded QPSK, 930
I/Q Scaling, 928
IS-95, 927
IS-95 Mod, 927
IS-95 Mod w/EQ, 927
IS-95 OQPSK, 930
IS-95 QPSK, 930
IS-95 w/EQ, 927
MSK, 930
Nyquist, 927
Optimize FIR For EVM ACP, 924
OQPSK, 930
 $\pi/4$ DQPSK, 930
Patt Trig In 1, 947
Patt Trig In 2, 947
PDC Off On, 947
Phase Dev, 929
Phase Polarity Normal Invert, 931
PN11, 924, 934, 936, 938
PN15, 924, 933, 934, 936, 938
PN20, 924, 934, 936, 938
PN23, 924, 934, 936, 938
PN9, 924, 933, 934, 936, 938
PN9 Mode Normal Quick, 917
QPSK, 930
Rate Full Half, 928
Recall Secondary Frame State, 931
Rectangle, 927
Reset & Run, 943
Restore PDC Factory Default, 925
Rise Delay, 920, 921
Rise Time, 922
Root Nyquist, 927
SACCH, 934, 937, 939
Save Secondary Frame State, 931
Secondary Frame Off On, 932
Sine, 923
Single, 943
SW, 934, 937, 939
Symbol Rate, 941
Sync Out Offset, 940
Timeslot Ampl Main Delta, 935
Timeslot Off On, 936
Trigger & Run, 943
Trigger Key, 932, 944
UN3/4 GSM Gaussian, 927
Up Custom, 940

Index

- Up TCH, [940](#)
- Up TCH All, [940](#)
- Up VOX, [940](#)
- User File, [923](#), [924](#), [933](#), [934](#), [936](#), [938](#)
- User FIR, [927](#)
- User FSK, [930](#)
- User I/Q, [930](#)
- pdcc subsystem keys
 - PRAM Files, [925](#)
- Performance Req softkey, [1072](#)
- Permuted ESN field, [492](#), [502](#)
- Phase Dev softkey
 - See* custom subsystem keys
 - See* DECT subsystem keys
 - See* EDGE subsystem keys
 - See* GSM subsystem keys
 - See* NADC subsystem keys
 - See* PDC subsystem keys
 - See* PHS subsystem keys
 - See* TETRA subsystem keys
- phase modulation subsystem keys
 - ΦM Sweep Time softkey, [195](#)
 - FM ΦM Normal High BW softkey, [192](#)
 - ΦM Dev Couple Off On, [197](#)
 - ΦM Dev softkey, [197](#)
 - ΦM Off On softkey, [196](#)
 - ΦM Path 1 2, [191](#)
 - ΦM Tone 2 Ampl Percent of Peak, [194](#)
 - ΦM Tone 2 Rate, [194](#)
 - Bus, [195](#)
 - Dual-Sine, [195](#)
 - Ext, [195](#)
 - Ext Coupling DC AC, [193](#)
 - Ext1, [196](#)
 - Ext2, [196](#)
 - Free Run, [195](#)
 - Incr Set, [192](#), [198](#)
 - Internal 1, [196](#)
 - Internal 2, [196](#)
 - Noise, [195](#)
 - Ramp, [195](#)
 - Sine, [195](#)
 - Square, [195](#)
 - Swept-Sine, [195](#)
 - Triangle, [195](#)
 - Trigger Key, [195](#)
- Phase Polarity field, [515](#)
- Phase Polarity Normal Invert softkey
 - See* custom subsystem keys
 - See* DECT subsystem keys
 - See* EDGE subsystem keys
 - See* GSM subsystem keys
 - See* PDC subsystem keys
 - See* PHS subsystem keys
 - See* TETRA subsystem keys
 - See* wideband CDMA base band generator subsystem keys and fields
- Phase Polarity Normal Inverted softkey, [1083](#)
- Phase Ref Set softkey, [47](#)
- PHS Off On softkey, [983](#)
- PHS softkey, [282](#), [283](#), [284](#)
- PHS subsystem keys
 - 128QAM, [969](#)
 - 16 1's & 16 0's, [958](#), [960](#), [963](#), [978](#), [982](#)
 - 16-Lvl FSK, [969](#)
 - 16PSK, [969](#)
 - 16QAM, [969](#)
 - 256QAM, [969](#)
 - 2-Lvl FSK, [969](#)
 - 32 1's & 32 0's, [958](#), [960](#), [963](#), [978](#), [982](#)
 - 32QAM, [969](#)
 - 4 1's & 4 0's, [958](#), [960](#), [963](#), [978](#), [982](#)
 - 4-Lvl FSK, [969](#)
 - 4QAM, [969](#)
 - 64 1's & 64 0's, [958](#), [960](#), [963](#), [978](#), [982](#)
 - 64QAM, [969](#)
 - 8 1's & 8 0's, [958](#), [960](#), [963](#), [978](#), [982](#)
 - 8-Lvl FSK, [969](#)
 - 8PSK, [969](#)
 - All Timeslots, [971](#)
 - APCO 25 C4FM, [966](#)
 - BBG Data Clock Ext Int, [948](#)
 - BBG Ref Ext Int, [965](#)
 - Begin Frame, [971](#)
 - Begin Timeslot #, [971](#), [972](#)
 - Bit Rate, [949](#)
 - BPSK, [969](#)
 - Bus, [970](#), [977](#)
 - C4FM, [969](#)
 - Continuous, [973](#)

- CSID, 961, 979
- Custom, 964
- D8PSK, 969
- Data Format Pattern Framed, 957
- Ext, 958, 960, 963, 970, 977, 978, 982
- Ext BBG Ref Freq, 965
- Ext Data Clock Normal Symbol, 964
- Ext Delay Bits, 975
- Ext Delay Off On, 976
- Ext Polarity Neg Pos, 976
- Fall Delay, 952, 953
- Fall Time, 952, 954
- Filter Alpha, 948
- Filter BbT, 949
- FIX4, 958, 959, 960, 963, 978, 979, 982
- Free Run, 974
- Gate Active Low High, 975
- Gated, 973
- Gaussian, 966
- Gray Coded QPSK, 969
- I/Q Scaling, 967
- IDLE, 961, 980
- IS-95, 966
- IS-95 Mod, 966
- IS-95 Mod w/EQ, 966
- IS-95 OQPSK, 969
- IS-95 QPSK, 969
- IS-95 w/EQ, 966
- MSK, 969
- Nyquist, 966
- Optimize FIR For EVM ACP, 958
- OQPSK, 969
- $\pi/4$ DQPSK, 969
- Patt Trig In 1, 976
- Patt Trig In 2, 976
- Phase Dev, 967, 968
- Phase Polarity Normal Invert, 969
- PHS Off On, 983
- PN11, 958, 960, 963, 978, 982
- PN15, 958, 960, 963, 978, 982
- PN20, 958, 960, 963, 978, 982
- PN23, 958, 960, 963, 978, 982
- PN9, 958, 960, 963, 978, 982
- PN9 Mode Normal Quick, 950
- PSID, 961, 980
- QPSK, 969
- Recall Secondary Frame State, 969
- Rectangle, 966
- Reset & Run, 974
- Restore PHS Factory Default, 959
- Rise Delay, 954, 955
- Rise Time, 956
- Root Nyquist, 966
- SA, 962, 981
- Save Secondary Frame State, 970
- Scramble Off On, 951
- Scramble Seed, 951
- Secondary Frame Off On, 970
- Sine, 957
- Single, 973
- Symbol Rate, 972
- SYNC, 964
- Sync Out Offset, 971
- TCH, 964
- TCH All, 964
- Timeslot Ampl Main Delta, 960, 979
- Timeslot Off On, 962, 981
- Timeslot Type, 982
- Trigger & Run, 974
- Trigger Key, 970, 977
- UN3/4 GSM Gaussian, 966
- User File, 957, 958, 960, 963, 978, 982
- User FIR, 966
- User FSK, 968, 969
- User I/Q, 968, 969
- UW, 962, 963, 980, 981
- phs subsystem keys
 - PRAM Files, 959
- PI Bits field, 1054
- PICH 10ms FramePulse (DRPS37) softkey, 1058, 1060, 1061, 1062, 1063
- PICH data (DRPS35) softkey, 1058, 1060, 1061, 1062, 1063
- PICH data-clk (DRPS34) softkey, 1058, 1060, 1061, 1062, 1063
- PICH softkey, 362, 1030, 1031
- PICH TimeSlot Pulse (DRPS36) softkey, 1058, 1060, 1061, 1062, 1063
- Pilot softkey, 228, 229, 231, 247, 254
- Playback Ratio field, 1034

Index

PN Offset field, [518](#)

PN Offset softkey, [252](#), [255](#)

PN11 softkey

See custom subsystem keys

See DECT subsystem keys

See EDGE subsystem keys

See GSM subsystem keys

See NADC subsystem keys

See PDC subsystem keys

See PHS subsystem keys

See sense subsystem keys

See TETRA subsystem keys

PN15 softkey

See CDMA2000 BBG subsystem keys and fields

See custom subsystem keys

See DECT subsystem keys

See EDGE subsystem keys

See GPS subsystem keys

See GSM subsystem keys

See NADC subsystem keys

See PDC subsystem keys

See PHS subsystem keys

See sense subsystem keys

See TETRA subsystem keys

See wideband CDMA base band generator
subsystem keys and fields

PN20 softkey

See custom subsystem keys

See DECT subsystem keys

See EDGE subsystem keys

See GSM subsystem keys

See NADC subsystem keys

See PDC subsystem keys

See PHS subsystem keys

See sense subsystem keys

See TETRA subsystem keys

PN23 softkey

See custom subsystem keys

See DECT subsystem keys

See EDGE subsystem keys

See GSM subsystem keys

See NADC subsystem keys

See PDC subsystem keys

See PHS subsystem keys

See sense subsystem keys

See TETRA subsystem keys

PN9 Mode Normal Quick softkey

See DECT subsystem keys

See GSM subsystem keys

See NADC subsystem keys

See PDC subsystem keys

See PHS subsystem keys

See TETRA subsystem keys

PN9 Mode Preset softkey, [159](#)

PN9 softkey

See CDMA2000 BBG subsystem keys and fields

See custom subsystem keys

See data subsystem keys

See DECT subsystem keys

See EDGE subsystem keys

See GPS subsystem keys

See GSM subsystem keys

See NADC subsystem keys

See PDC subsystem keys

See PHS subsystem keys

See sense subsystem keys

See TETRA subsystem keys

See wideband CDMA base band generator
subsystem keys and fields

polarity

awgn subsystem, [212](#)

markers

cdma arb subsystem, [226](#)

cdma2000 arb subsystem, [260](#)

dmodulation subsystem, [280](#)

dual ARB subsystem, [312](#), [481](#)

multitone subsystem, [337](#)

wideband CDMA ARB subsystem, [375](#)

polarity markers

awgn subsystem, [212](#)

Polarity Normal Invert softkey, [897](#)

Port Config softkey, [400](#)

Power Control Signal Polarity Neg Pos softkey,
[1113](#)

Power field

See CDMA2000 BBG subsystem keys and fields

See wideband CDMA baseband generator
subsystem keys and fields

Power Hold Off On softkey, [1110](#)

Power Meter softkey, [78](#)

- Power Mode Norm TPC softkey, 1113
- Power On Last Preset softkey, 158
- Power Search Manual Auto softkey, 60, 62
- Power Search Reference Fixed Mod softkey, 61
- Power softkey, 369
- power subsystem keys
 - ALC Off On, 62
 - Alt Amp Delta, 63
 - Alt Ampl Off On, 64
 - Ampl, 49, 66
 - Ampl Offset, 68
 - Ampl Ref Off On, 67
 - Ampl Ref Set, 66
 - Ampl Start, 49, 67
 - Ampl Stop, 49, 68
 - Amplitude, 66, 69
 - Atten Hold Off On, 65
 - Auto, 58, 59
 - Do Power Search, 60, 62
 - Ext Detector, 63
 - Internal, 63
 - Off, 49, 66
 - Power Search Manual Auto, 60, 62
 - Power Search Reference Fixed Mod, 61
 - Set ALC Level, 60
 - Set Atten, 65
 - Source Module, 63
 - Span Type User Full softkey, 62
 - Start Frequency, 61
 - step, 69
 - Stop Frequency, 61
- PPCCPCH softkey, 362, 363
- Pp-m field, 1129, 1145
- PRACH Mode Single Multi softkey, 1126
- PRACH Power Setup Mode Pp-m Total softkey, 1133
- PRACH Processing (RPS19) softkey
 - See* wideband CDMA base band generator subsystem keys and fields
- PRACH Scrambling Code field, 1134
- PRACH softkey, 1109
- PRACH Trigger Polarity Neg Pos softkey, 1138
- PRACH Trigger softkey, 1138
- PRACH Trigger Source Immedi Trigger softkey, 1138
- PRAM
 - downloads, 112
 - list, 113
- PRAM DATA BLOCK, 114
- pram files
 - CUSTOM subsystem keys, 564
 - DECT subsystem keys, 590
 - EDGE subsystem keys, 638
 - GSM subsystem keys, 789
 - NADC subsystem keys, 890
 - PDC subsystem keys, 925
 - PHS subsystem keys, 959
 - TETRA subsystem keys, 995
- PRAM LIST, 114
- PRAM?, 114
- PRAT field, 509
- Pre Sig field, 1130
- Preamble power average field, 1132
- Preamble Pulse (RPS21) softkey
 - See* wideband CDMA base band generator subsystem keys and fields
- Preamble Raw Data (RPS15) softkey
 - See* wideband CDMA base band generator subsystem keys and fields
- Preamble Raw Data Clock (RPS16) softkey
 - See* wideband CDMA base band generator subsystem keys and fields
- Preamble softkey, 1116
- precise talking and forgiving listening, 7
- Preset hardkey, 158
- Preset List softkey, 21, 56
- Preset Normal User softkey, 160
- programming guide, lxxi
- PSCH softkey, 362
- PSCH State field, 1056
- PSID softkey, 961, 980
- pulse modulation subsystem keys
 - Ext Pulse, 202
 - Int Doublet, 202
 - Int Free-Run, 202
 - Int Gated, 202
 - Int Triggered, 202
 - Internal Square, 202
 - Pulse Off On, 202
 - Pulse Period, 200

Index

- Pulse Rate, 199
 - Pulse Width, 201
 - Pulse softkeys
 - Pulse Off On, 202
 - Pulse Period, 200
 - Pulse Rate, 199
 - Pulse Width, 201
 - Pulse/RF blanking, 310
 - pulse/RF blanking markers
 - awgn subsystem, 210
 - cdma arb subsystem, 224
 - cdma2000 arb, 258
 - dmodulation, 277
 - dual ARB subsystem, 310
 - wideband cdma arb, 373
 - Puncture fields, 1178, 1185
 - Puncture softkey, 1066
 - PwrOffs field, 1065, 1163
 - PWT softkey, 282, 283, 284
- Q**
- Q Gain softkey, 394
 - Q Offset softkey, 30, 396
 - QOF field, 493, 503
 - QPSK softkey
 - See* custom subsystem keys
 - See* DECT subsystem keys
 - See* Dmodulation subsystem keys
 - See* EDGE subsystem keys
 - See* GSM subsystem keys
 - See* NADC subsystem keys
 - See* PDC subsystem keys
 - See* PHS subsystem keys
 - See* TETRA subsystem keys
 - Quadrature Angle Adjustment softkey, 25, 30
 - Quarter softkey, 535, 540
 - quotes, SCPI command use of, 17
- R**
- RACH TrCH softkey, 1116
 - Radio Config field
 - See* CDMA2000 BBG subsystem keys and fields
 - Radio Config softkey, 253
 - RadioConfig 1/2 Access softkey, 485
 - RadioConfig 1/2 Traffic softkey, 485
 - RadioConfig 3/4 Common Control softkey, 485
 - RadioConfig 3/4 Enhanced Access softkey, 485
 - RadioConfig 3/4 Traffic softkey, 485
 - Ramp field, 493
 - Ramp softkey, 175, 182, 189, 195
 - Ramp Step field, 1129, 1144
 - Ramp Time field, 493
 - Random Seed Fixed Random softkey, 342
 - Random softkey, 361, 369
 - Ranging Code C/A P C/A+P softkey, 773
 - Rate Full Half softkey, 894, 928
 - Rate Match Attr field, 1082, 1178, 1185
 - Rate softkey, 252, 255
 - RCDMA softkey, 101
 - real response data, 10
 - Real-time AWGN Off On softkey, 469
 - real-time AWGN subsystem keys
 - Bandwidth, 469
 - Real-time AWGN Off On, 469
 - Real-time GPS Off On softkey, 775
 - Real-time MSGPS Off On softkey, 778
 - Real-time Noise softkey, 314
 - RECALL Reg softkey, 90
 - Recall Secondary Frame State softkey
 - See* DECT subsystem keys
 - See* EDGE subsystem keys
 - See* GSM subsystem keys
 - See* NADC subsystem keys
 - See* PDC subsystem keys
 - See* PHS subsystem keys
 - See* TETRA subsystem keys
 - Rectangle softkey
 - See* CDMA ARB subsystem keys
 - See* CDMA2000 ARB subsystem keys
 - See* CDMA2000 BBG subsystem keys and fields
 - See* custom subsystem keys
 - See* DECT subsystem keys
 - See* Dmodulation subsystem keys
 - See* dual ARB subsystem keys
 - See* EDGE subsystem keys
 - See* GPS subsystem keys
 - See* GSM subsystem keys
 - See* NADC subsystem keys
 - See* PDC subsystem keys

- See* PHS subsystem keys
- See* TETRA subsystem keys
- See* wideband CDMA ARB subsystem keys
- See* wideband CDMA base band generator subsystem keys and fields
- Ref Data Rate field, [1085](#), [1115](#)
- Ref Oscillator Source Auto Off On softkey, [48](#)
- Ref Sensitivity softkey, [1072](#)
- Reference Freq softkey, [483](#)
 - See* AWGN subsystem keys
 - See* bluetooth subsystem keys
 - See* CDMA ARB subsystem keys
 - See* CDMA2000 ARB subsystem keys
 - See* Dmodulation subsystem keys
 - See* dual ARB subsystem keys
 - See* multitone subsystem keys
 - See* wideband CDMA ARB subsystem keys
- Reference Frequency softkey, [388](#)
- Reference Out softkey, [419](#)
- references, [lxxi](#)
- Rename File, [123](#)
- Rename File softkey, [127](#)
- Reserved field, [509](#)
- Reset & Run softkey
 - See* CDMA ARB subsystem keys
 - See* CDMA2000 ARB subsystem keys
 - See* custom subsystem keys
 - See* DECT subsystem keys
 - See* Dmodulation subsystem keys
 - See* dual ARB subsystem keys
 - See* EDGE subsystem keys
 - See* GSM subsystem keys
 - See* NADC subsystem keys
 - See* PDC subsystem keys
 - See* PHS subsystem keys
 - See* TETRA subsystem keys
 - See* wideband CDMA ARB subsystem keys
- Reset RS-232 softkey, [79](#)
- Reset to Initial Power softkey, [1112](#)
- Resolution softkey, [424](#)
- resolving error messages/setting conflicts, [676](#), [820](#)
- response data types. *See* SCPI commands response types
- Restart softkey, [777](#)
- Restore DECT Factory Default softkey, [590](#)
- Restore EDGE Factory Default softkey, [639](#)
- Restore Factory Default softkey, [789](#)
- Restore NADC Factory Default softkey, [891](#)
- Restore PDC Factory Default softkey, [925](#)
- Restore PHS Factory Default softkey, [959](#)
- Restore Sys Defaults softkey, [159](#)
- Restore TETRA Factory Default softkey, [996](#)
- Resync Limits softkey, [462](#)
- Retrigger Mode Off On softkey, [376](#)
- Reverse softkey, [228](#)
- Revert to Default Cal Settings softkey, [73](#)
- rf blanking, [310](#)
- RF blanking/pulse markers
 - awgn subsystem, [210](#)
 - cdma arb subsystem, [224](#)
 - cdma2000 arb subsystem, [258](#)
 - dmodulation subsystem, [277](#)
 - dual ARB subsystem, [310](#)
 - wideband cdma arb subsystem, [373](#)
- RF On/Off hardkey, [129](#)
- Right Alternate softkey, [361](#)
- Right softkey, [1034](#)
- Rise Delay softkey
 - See* custom subsystem keys
 - See* DECT subsystem keys
 - See* EDGE subsystem keys
 - See* GSM subsystem keys
 - See* NADC subsystem keys
 - See* PDC subsystem keys
 - See* PHS subsystem keys
 - See* TETRA subsystem keys
- Rise Time softkey
 - See* custom subsystem keys
 - See* DECT subsystem keys
 - See* EDGE subsystem keys
 - See* GSM subsystem keys
 - See* NADC subsystem keys
 - See* PDC subsystem keys
 - See* PHS subsystem keys
 - See* TETRA subsystem keys
- Rising softkey, [553](#)
- RMC 144 kbps (25.141) softkey, [1146](#)
- RMC 384 kbps (25.141) softkey, [1146](#)
- RMC 64 kbps (25.141) softkey, [1146](#)
- RMC122 kbps (25.141) softkey, [1146](#)

Index

RMS header info, [298](#), [299](#)

RMS noise header info, [298](#)

Root Nyquist softkey

See CDMA ARB subsystem keys

See CDMA2000 ARB subsystem keys

See CDMA2000 BBG subsystem keys and fields

See custom subsystem keys

See DECT subsystem keys

See Dmodulation subsystem keys

See dual ARB subsystem keys

See EDGE subsystem keys

See GPS subsystem keys

See GSM subsystem keys

See NADC subsystem keys

See PDC subsystem keys

See PHS subsystem keys

See TETRA subsystem keys

See wideband CDMA ARB subsystem keys

See wideband CDMA base band generator
subsystem keys and fields

rotate markers, [306](#)

Rotation softkey, [396](#)

route subsystem keys

Burst Gate In Polarity Neg Pos, [130](#), [131](#)

Data Clock Out Neg Pos, [133](#)

Data Clock Polarity Neg Pos, [130](#), [132](#), [134](#)

Data Out Polarity Neg Pos, [133](#), [135](#)

Data Polarity Neg Pos, [131](#), [132](#)

DATA/CLK/SYNC Rear Outputs Off On, [135](#)

Symbol Sync Out Polarity Neg Pos, [134](#), [135](#)

Symbol Sync Polarity Neg Pos, [131](#), [132](#)

RS-232 Baud Rate softkey, [79](#)

RS-232 ECHO Off On softkeys, [79](#)

RS-232 Timeout softkeys, [80](#)

Run Complete Self Test softkey, [92](#)

runtime scaling, [316](#), [339](#)

S

S softkey, [652](#), [806](#)

See DECT subsystem keys

SA softkey, [962](#), [981](#)

SACCH softkey, [900](#), [904](#), [934](#), [937](#), [939](#)

Samples softkey, dual ARB trigger delay, [325](#)

Sanitize softkey, [161](#)

Satellite ID softkey, [775](#)

Save Reg softkey, [91](#)

Save Secondary Frame State softkey

See DECT subsystem keys

See EDGE subsystem keys

See GSM subsystem keys

See NADC subsystem keys

See PDC subsystem keys

See PHS subsystem keys

See TETRA subsystem keys

Save Seq[n] Reg[nn] softkey, [91](#)

Save Setup To Header softkey, [206](#), [220](#), [245](#), [273](#),
[301](#), [330](#), [348](#), [473](#)

Save User Preset softkey, [160](#)

Scale to 0dB softkey

See CDMA ARB subsystem keys

See CDMA2000 ARB subsystem keys

See CDMA2000 BBG subsystem keys and fields

See wideband CDMA ARB subsystem keys

See wideband CDMA base band generator
subsystem keys and fields

Scale Waveform Data softkey, [316](#)

scaling

during playback, [316](#), [339](#)

waveform files, [316](#)

Scaling softkey, [316](#), [397](#)

SCCPCH softkey, [362](#), [363](#)

Scenario softkey, [778](#)

SCFN field, [1070](#), [1168](#)

SCH slot-pulse (DRPS10) softkey, [1058](#), [1060](#),
[1061](#), [1062](#), [1063](#)

SCPI

errors, [155](#)

SCPI command subsystems

3GPP W-CDMA HSPA, [674](#)

all, [468](#)

amplitude modulation, [172](#)

AWGN, [205](#)

AWGN real-time, [469](#)

bluetooth, [470](#)

calculate, [404](#)

calibration, [72](#)

CDMA ARB, [215](#)

CDMA2000 ARB, [240](#)

CDMA2000 BBG, [485](#)

communication, [75](#)

- correction, 20
- custom, 554
- data, 414
- DECT, 580
- diagnostic, 81
- digital, 386
- digital modulation, 22
- display, 85
- Dmodulation, 270
- Dual ARB, 294
- E4438C, 204
- EDGE, 629
- frequency, 38
- frequency modulation, 179
- GPS subsystem, 769
- GSM, 779
- HSDPA over W-CDMA, 818
- IEEE 488.2 common commands, 88
- input, 422, 428
- list/sweep, 49
- low frequency output, 186
- mass memory, 124
- memory, 94
- MSGPS subsystem, 776
- multitone, 330
- N5102A, 386
- NADC, 880
- output, 128
- PDC, 915
- phase modulation, 191
- PHS, 948
- power, 58
- pulse modulation, 199
- route, 130
- sense, 431
- status, 136
- system, 154
- TETRA, 984
- trigger, 166
- unit, 170
- wideband CDMA ARB, 344
- wideband CDMA base band generator, 1028
- SCPI commands
 - command tree paths, 7
 - parameter and response types, 7
 - parameter types
 - boolean, 10
 - discrete, 9
 - extended numeric, 8
 - numeric, 8
 - string, 10
 - response data types
 - discrete, 11
 - integer, 11
 - numeric boolean, 11
 - real, 10
 - string, 11
 - root command, 6
- SCPI reference, lxxi
- SCPI softkey, 156, 159
- Scramble Code softkey, 361, 367, 369
- Scramble Off On softkey, 951, 987
- Scramble Offset softkey, 361, 369
- Scramble Seed softkey, 951, 987
- Scrambling Code field, 1063, 1064, 1160
- Screen Saver Delay
 - 1 hr softkey, 164
- Screen Saver Mode softkeys, 164
- Screen Saver Off On softkeys, 164
- Second DPDCH I Q softkey, 367
- Secondary Frame Off On softkey
 - See* DECT subsystem keys
 - See* EDGE subsystem keys
 - See* GSM subsystem keys
 - See* NADC subsystem keys
 - See* PDC subsystem keys
 - See* PHS subsystem keys
 - See* TETRA subsystem keys
- secure wave directory, 116
- security functions
 - erase, 161
 - none, 161
 - overwrite, 161, 163
 - sanitize, 161, 163
 - secure display, 160
 - secure mode, 162
- segment advance
 - trigger response, 322
- Segment Advance softkey, 319
- Select File softkey, 249, 282

Index

- Select Scenario softkey, 778
- Select Seq softkey, 90
- Select Waveform softkey, 327, 328
- sense subsystem keys
 - Adjust Gain, 443
 - Aux, 444, 460, 466
 - Aux I/O Trigger Polarity Pos Neg, 466
 - BER Mode Off On, 431, 435, 454
 - BERT Off On, 463
 - BERT Resync Off On, 463
 - Bit Count, 445, 447
 - Bit Delay Off On, 465
 - Block Count, 434, 436, 438, 450, 454
 - Block Erasure, 432, 437, 450, 451, 452, 454, 455
 - Bus, 444, 460, 466
 - Class Ib Bit Error, 457, 458
 - Class II Bit Error, 458
 - Cycle Count, 465
 - Delay Bits, 465
 - EDGE BERT Off On, 448
 - Error Count, 448, 463
 - Exceeds Any Thresholds, 458
 - Ext, 444, 460, 466
 - Ext Frame Trigger Delay, 433
 - External Frame Polarity Net Pos, 433
 - Frame Count, 453, 456
 - Frame Erasure, 458
 - Frame Trigger Source Int Ext, 434
 - GSM BERT Off On, 461
 - High Amplitude, 435, 439, 446
 - Immediate, 444, 460, 466
 - Initial Bit Count, 447
 - Initial Block Count, 437, 440
 - Initial Frame Count, 457
 - Low Amplitude, 436, 439, 446, 453
 - Measurement Mode BER% Search, 456
 - Measurement Mode BLER% Search, 442
 - No Thresholds, 432, 437, 452, 455, 458, 464
 - Pass Amplitude, 436, 440, 447
 - PN11, 462
 - PN15, 462
 - PN20, 462
 - PN23, 462
 - PN9, 462
 - Resync Limits, 462
 - Spcl Pattern 0's 1's, 461
 - Spcl Pattern Ignore Off On, 462
 - Spectrum Invert Off On, 443, 457
 - Stop Measurement, 441, 455
 - Sync Source BCH PDCH, 444
 - Sync Source BCH TCH, 460
 - Synchronize to BCH/PDCH, 443
 - Synchronize to BCH/TCH, 459
 - Target BER %, 435, 438
 - Timeslot, 442, 455
 - Total Bits, 464
 - Trigger Key, 444, 460, 466
 - Uplink Timing Advance, 445, 461
- SEQ softkey, 102
- sequence, creating, 317
- service
 - guide, lxxi
- Set ALC Level softkey, 60
- Set Atten softkey, 65
- Set Marker Off All Points softkey, 305
- Set Marker Off Range Of Points softkey, 304
- Set Marker On Range Of Points softkey, 306
- setting conflicts, resolving, 676, 820
- setting markers, 306
- setup sweep, 49
- SF/2 softkey, 1164
- SF2 softkey, 1066
- SFN reset-signal (DRPS5) softkey, 1058, 1060, 1061, 1062, 1063
- SFN RST Polarity softkey, 1160
- SFN-CFN Frame Offset softkey, 1109
- SHAPE softkey, 102
- shift markers, 306
- Signal Type softkey, 398
- Signature field, 1145
- Sine softkey
 - See amplitude modulation subsystem keys
 - See DECT subsystem keys
 - See EDGE subsystem keys
 - See frequency modulation subsystem keys
 - See GSM subsystem keys
 - See low frequency output subsystem keys
 - See NADC subsystem keys
 - See PDC subsystem keys
 - See phase modulation subsystem keys

- See* PHS subsystem keys
 - See* TETRA subsystem keys
- single
 - segment advance, [322](#)
- Single softkey
 - dual ARB subsystem keys, [322](#)
 - See* CDMA ARB subsystem keys
 - See* CDMA2000 ARB subsystem keys
 - See* custom subsystem keys
 - See* DECT subsystem keys
 - See* Dmodulation subsystem keys
 - See* dual ARB subsystem keys
 - See* EDGE subsystem keys
 - See* GSM subsystem keys
 - See* NADC subsystem keys
 - See* PDC subsystem keys
 - See* PHS subsystem keys
 - See* TETRA subsystem keys
 - See* wideband CDMA ARB subsystem keys
- Single Sweep softkey, [167](#)
- skew, [31](#), [32](#)
- skew, quadrature (angle) adjustment
 - BBG, [25](#)
 - RF path, [30](#)
- Slot Format field, [1035](#), [1042](#), [1092](#), [1103](#), [1120](#), [1125](#)
- softkey, [123](#)
- software options, [82](#)
- Source Module softkey, [63](#)
- Span Type User Full softkey, [62](#)
- Spcl Pattern 0's 1's softkey, [461](#)
- Spcl Pattern Ignore Off On softkey, [462](#)
- Spectrum Invert Off On softkey
 - See* sense subsystem keys
- Spread Rate 1 softkey, [247](#), [254](#), [262](#)
- Spread Rate 3, [254](#)
- Spread Rate 3 softkey, [247](#), [262](#)
- Spread Rate field, [517](#)
- Spreading Type Direct Mcarrier, [247](#)
- Spreading Type Direct Mcarrier softkey, [263](#)
- Spurious Response softkey, [1072](#)
- Square softkey, [175](#), [182](#), [189](#), [195](#)
- square wave pulse rate
 - internally generated, [199](#)
- SR1 9 Channel softkey, [249](#)
- SR1 Pilot softkey, [249](#)
- SR3 Direct 9 Channel softkey, [249](#)
- SR3 Direct Pilot softkey, [249](#)
- SR3 Mcarrier 9 Channel softkey, [249](#)
- SR3 MCarrier Pilot softkey, [249](#)
- SS softkey, [798](#)
- SSB softkey, [1006](#), [1011](#)
- SSCH 2nd Scramble Group field, [1064](#)
- SSCH Power field, [1064](#)
- SSCH softkey, [362](#)
- SSCH State field, [1065](#)
- Standard softkey, [361](#)
- Start Access Slot Position in 80ms Period field, [1131](#)
- Start Frequency softkey, [61](#), [74](#)
- Start Sub-Channel# field, [1135](#)
- State field
 - See* CDMA2000 BBG subsystem keys and fields
- State softkey, [103](#), [124](#)
- STD softkey, [1089](#)
- Step Dwell softkey, [56](#)
- Step Power field, [1112](#)
- Stop Frequency softkey, [61](#), [74](#)
- Stop Measurement softkey
 - See* sense subsystem keys
- Store Custom CDMA State softkey, [232](#), [251](#), [254](#)
- Store Custom Dig Mod State softkey, [285](#)
- Store Custom Multicarrier softkey, [231](#), [249](#)
- Store Custom W-CDMA State softkey, [357](#), [360](#)
- Store To File softkey, [21](#), [123](#), [127](#), [340](#), [369](#)
- string response data, [11](#)
- string SCPI parameter, [10](#)
- strings, quote usage, [17](#)
- STS softkey, [1007](#), [1012](#)
- Sub Channel Timing (RPS17) softkey
 - See* wideband CDMA base band generator subsystem keys and fields
- Subnet Mask softkey, [77](#)
- subsystems, SCPI commands
 - See* SCPI command subsystems
- Sum softkey, [24](#)
- Summing Ratio (SRC1/SRC2) x.xx dB softkey, [36](#)
- SW softkey, [934](#), [937](#), [939](#)
- Swap IQ softkey, [393](#)
- Sweep Direction Down Up softkey, [50](#)
- Sweep Repeat Single Cont softkey, [166](#)

Index

Sweep Retrace Off On softkey, 54
sweep setup, 49
Sweep Type List Step softkey, 55
sweep/list subsystem keys
 Load From Selected File
 Store to File, 49
Swept-Sine softkey, 175, 182, 189, 195
Symbol Out Polarity Neg Pos softkey, 134
Symbol Rate field, 1092, 1101, 1124
Symbol Rate softkey, 286, 361, 369, 665, 1120
Symbol Sync Out Polarity Neg Pos softkey, 135
Symbol Sync Polarity Neg Pos softkey, 131, 132
Symbol Timing Err softkey, 478
Sync Out Offset softkey, 621, 664, 809, 906, 940,
 971, 1019
SYNC softkey, 901, 904, 964
Sync softkey, 229, 808
Sync Source BCH PDCH softkey, 444
Sync Source BCH TCH softkey, 460
Sync Source SFN FCik ESG softkey, 1161
Synchronize to BCH/PDCH softkey, 443
Synchronize to BCH/TCH softkey, 459
System ID field, 510
system subsystem keys
 8648A/B/C/D, 156, 159
 8656B,8657A/B, 156, 159
 8657D NADC, 156, 159
 8657D PDC, 156, 159
 8657J PHS, 156, 159
 Activate Secure Display, 160
 Enter Secure Mode, 162
 erase, 161
 Erase All, 161
 Erase and Overwrite All, 163
 Erase and Sanitize All, 163
 Error Info, 155
 Help Mode Single Cont, 156
 none, 161
 overwrite, 161
 PN9 Mode Preset, 159
 Power On Last Preset, 158
 Preset, 158
 Preset Normal User, 160
 Restore Sys Defaults, 159
 sanitize, 161

Save User Preset, 160
SCPI, 156, 159
Screen Saver Delay
 1 hr, 164
Screen Saver Mode, 164
Screen Saver Off On, 164
Time/Date, 154, 165
View Next Error Message, 155

T

T1 softkey, 661
T2 softkey, 662
Target BER % softkey
 See sense subsystem keys
TCH All softkey, 964
TCH softkey, 964
TCH/FS softkey, 648, 651, 800
tDPCH Offset field, 1043
Test Model 1 w/16 DPCH softkey, 352, 358
Test Model 1 w/32 DPCH softkey, 352, 358
Test Model 1 w/64 DPCH softkey, 352, 358
Test Model 2 softkey, 352, 358
Test Model 3 w/16 DPCH softkey, 352, 358
Test Model 3 w/32 DPCH softkey, 352, 358
Test Model 4 softkey, 352, 358
Test Model 5 w/2HSPDSCH softkey, 352, 358
Test Model 5 w/4HSPDSCH softkey, 352, 358
Test Model 5 w/8HSPDSCH softkey, 352, 358
TETRA Off On softkey, 1027
TETRA softkey, 282, 283, 284
TETRA subsystem keys
 128QAM, 1001
 16 1's & 16 0's, 994, 1003, 1005, 1007, 1008,
 1010, 1012, 1014, 1015, 1016
 16PSK, 1001
 16QAM, 1001
 256QAM, 1001
 2-Lvl FSK, 1001
 32 1's & 32 0's, 994, 1003, 1005, 1007, 1008,
 1010, 1012, 1014, 1015, 1016
 32QAM, 1001
 4 1's & 4 0's, 994, 1003, 1005, 1007, 1008, 1010,
 1012, 1014, 1015, 1016
 4-Lvl FSK, 1001
 4QAM, 1001

- 64 1's & 64 0's, 994, 1003, 1005, 1007, 1008, 1010, 1012, 1014, 1015, 1016
- 64QAM, 1001
- 8 1's & 8 0's, 994, 1003, 1005, 1007, 1008, 1010, 1012, 1014, 1015, 1016
- 8PSK, 1001
- All Timeslots, 1019
- APCO 25 C4FM, 998
- B, 1006, 1011
- B1, 1004, 1009
- B2, 1004, 1009
- BBG Data Clock Ext Int, 984
- BBG Ref Ext Int, 997
- Begin Frame, 1019
- Begin Timeslot #, 1019, 1020
- Bit Rate, 985
- BPSK, 1001
- Bus, 1002, 1024
- Continuous, 1022
- D8PSK, 1001
- Data Format Pattern Framed, 993
- Dn Custom Cont, 1017
- Dn Normal Cont, 1017
- Dn Normal Disc, 1017
- Dn Sync Cont, 1017
- Dn Sync Disc, 1017
- Ext, 994, 1002, 1003, 1005, 1007, 1008, 1010, 1012, 1014, 1015, 1016, 1024
- Ext BBG Ref Freq, 997
- Ext Data Clock Normal Symbol, 996
- Ext Delay Bits, 1025
- Ext Delay Off On, 1025
- Ext Polarity Neg Pos, 1026
- Fall Delay, 987, 989
- Fall Time, 988, 989
- FCOR, 1006, 1011
- Filter Alpha, 984
- Filter BbT, 985
- FIX4, 994, 995, 1003, 1005, 1007, 1008, 1010, 1012, 1014, 1015, 1016, 1017
- Free Run, 1022
- Freq Dev, 999
- Gate Active Low High, 1023
- Gated, 1022
- Gaussian, 998
- Gray Coded QPSK, 1001
- I/Q Scaling, 999
- IS-95, 998
- IS-95 Mod, 998
- IS-95 Mod w/EQ, 998
- IS-95 OQPSK, 1001
- IS-95 QPSK, 1001
- IS-95 w/EQ, 998
- MSK, 1001
- Nyquist, 998
- Optimize FIR For EVM ACP, 994
- OQPSK, 1001
- $\pi/4$ DQPSK, 1001
- Patt Trig In 1, 1026
- Patt Trig In 2, 1026
- Phase Dev, 1000
- Phase Polarity Normal Invert, 1001
- PN11, 994, 1003, 1005, 1007, 1008, 1010, 1012, 1014, 1015, 1016
- PN15, 994, 1003, 1005, 1007, 1008, 1010, 1012, 1014, 1015, 1016
- PN20, 994, 1003, 1005, 1007, 1008, 1010, 1012, 1014, 1015, 1016
- PN23, 994, 1003, 1005, 1007, 1008, 1010, 1012, 1014, 1015, 1016
- PN9, 994, 1003, 1005, 1007, 1008, 1010, 1012, 1014, 1015, 1016
- PN9 Mode Normal Quick, 986
- QPSK, 1001
- Recall Secondary Frame State, 1002
- Rectangle, 998
- Reset & Run, 1022
- Restore TETRA Factory Default, 996
- Rise Delay, 990, 991
- Rise Time, 991, 992
- Root Nyquist, 998
- Save Secondary Frame State, 1002
- Scramble Off On, 987
- Scramble Seed, 987
- Secondary Frame Off On, 1003
- Sine, 993
- Single, 1022
- SSB, 1006, 1011
- STS, 1007, 1012
- Symbol Rate, 1020

Index

- Sync Out Offset, [1019](#)
- TETRA Off On, [1027](#)
- Timeslot Ampl Main Delta, [1013](#)
- Timeslot Off On, [1013](#)
- Trigger & Run, [1022](#)
- Trigger Key, [1002](#), [1024](#)
- TS, [1004](#), [1009](#), [1013](#), [1014](#), [1016](#)
- UN3/4 GSM Gaussian, [998](#)
- Up Control 1, [1017](#)
- Up Control 2, [1017](#)
- Up Custom, [1017](#)
- Up Normal, [1017](#)
- User File, [993](#), [994](#), [1003](#), [1005](#), [1007](#), [1008](#), [1010](#),
[1012](#), [1014](#), [1015](#), [1016](#)
- User FIR, [998](#)
- User FSK, [1000](#), [1001](#)
- User I/Q, [1000](#), [1001](#)
- tetra subsystem keys
 - PRAM Files, [995](#)
- TFCI Field Off On softkey, [361](#), [366](#), [369](#), [371](#)
- TFCI Pat field, [1043](#)
- TFCI Pattern field, [1093](#), [1121](#)
- TFCI State field, [1094](#), [1122](#)
- Tfirst field, [1036](#)
- TGCFN field, [1066](#), [1163](#)
- TGD field, [1067](#), [1164](#)
- Tgl field, [1036](#)
- TGL1 field, [1067](#), [1165](#)
- TGL2 field, [1067](#), [1165](#), [1166](#)
- TGPL1 field, [1068](#), [1165](#)
- TGPRC field, [1166](#)
- TGPS Inactive Active softkey, [1167](#)
- TGSN field, [1069](#), [1167](#)
- Through softkey, [32](#), [205](#), [208](#), [217](#), [222](#), [241](#), [246](#),
[270](#), [275](#), [302](#), [303](#), [331](#), [333](#), [348](#), [350](#), [472](#), [479](#)
- Time field, [510](#)
- Time softkey, dual ARB trigger delay, [325](#)
- Time/Date softkey, [154](#), [165](#)
- Timeslot Ampl Main Delta softkey
 - See* DECT subsystem keys
 - See* EDGE subsystem keys
 - See* NADC subsystem keys
 - See* PDC subsystem keys
 - See* PHS subsystem keys
 - See* TETRA subsystem keys
- Timeslot Off On softkey
 - See* DECT subsystem keys
 - See* EDGE subsystem keys
 - See* GSM subsystem keys
 - See* NADC subsystem keys
 - See* PHS subsystem keys
 - See* TETRA subsystem keys
- Timeslot Offset softkey, [1134](#)
- Timeslot softkey
 - See* sense subsystem keys
- Timeslot Type softkey, [982](#)
- Timing Offset softkey, [1135](#), [1160](#), [1170](#)
- tOCNS Offset field, [1050](#)
- Toggle Marker 1 2 3 4 softkey, [317](#)
- Toggle State softkey, [338](#), [340](#)
- Total Bits field, [1174](#)
- Total Bits softkey, [464](#)
- Total Block field, [1176](#)
- TotalPwr field, [1087](#), [1117](#)
- TPC Pat Steps field, [1094](#)
- TPC Pat Trig Polarity Neg Pos softkey, [1096](#)
- TPC Pattern field, [1096](#)
- TPC Steps field, [1044](#)
- TPC UserFile Trig field, [1097](#)
- Tp-m field, [1136](#)
- Tp-p field, [1137](#)
- Traffic Bearer softkey, [596](#), [607](#)
- Traffic Bearer with Z field softkey, [596](#), [607](#)
- Traffic softkey, [229](#)
- Transp Chan A softkey, [1039](#)
- Transp Chan B softkey, [1039](#)
- Transp Position Flexible Fixed softkey, [1081](#)
- Transport CH softkey, [1051](#)
- TrCH BER field, [1102](#)
- TrCh BlkSize 168 softkey, [1133](#)
- TrCh BlkSize 360 softkey, [1133](#)
- TrCH State Off On softkey, [1186](#)
- TrCHI State Off On softkey, [1083](#)
- Triangle softkey, [175](#), [182](#), [189](#), [195](#)
- Trigger & Run softkey
 - See* CDMA ARB subsystem keys
 - See* CDMA2000 ARB subsystem keys
 - See* custom subsystem keys
 - See* DECT subsystem keys
 - See* Dmodulation subsystem keys

- See* dual ARB subsystem keys
- See* EDGE subsystem keys
- See* GSM subsystem keys
- See* NADC subsystem keys
- See* PDC subsystem keys
- See* PHS subsystem keys
- See* TETRA subsystem keys
- See* wideband CDMA ARB subsystem keys
- Trigger Advance field, [552](#)
- Trigger In Polarity Neg Pos softkey, [168](#)
- Trigger Key softkey
 - list/sweep subsystem, [54](#)
 - See* amplitude modulation subsystem keys
 - See* CDMA ARB subsystem keys
 - See* CDMA2000 ARB subsystem keys
 - See* DECT subsystem keys
 - See* Dmodulation subsystem keys
 - See* dual ARB subsystem keys
 - See* EDGE subsystem keys
 - See* frequency modulation subsystem keys
 - See* GSM subsystem keys
 - See* low frequency output subsystem keys
 - See* NADC subsystem keys
 - See* PDC subsystem keys
 - See* phase modulation subsystem keys
 - See* PHS subsystem keys
 - See* sense subsystem keys
 - See* TETRA subsystem keys
 - See* trigger subsystem keys
 - See* wideband CDMA ARB subsystem keys
- Trigger Out Polarity Neg Pos softkey, [167](#)
- trigger source, list sweep, [54](#)
- trigger subsystem keys
 - Bus, [168](#), [552](#)
 - Ext, [168](#), [552](#)
 - Free Run, [168](#), [552](#)
 - Single Sweep, [167](#)
 - Sweep Repeat Single Cont, [166](#)
 - Trigger In Polarity Neg Pos, [168](#)
 - Trigger Key, [168](#), [552](#)
 - Trigger Out Polarity Neg Pos, [167](#)
- Trigger Sync Reply (RPS7) softkey
 - See* wideband CDMA base band generator subsystem keys and fields
- triggers
 - response selection
 - segment advance mode, dual ARB, [322](#)
 - Truncated PN9 softkey, [471](#)
 - TS softkey, [808](#), [1004](#), [1009](#), [1013](#), [1014](#), [1016](#)
 - TSC0 softkey, [652](#), [662](#), [799](#), [806](#)
 - TSC1 softkey, [652](#), [662](#), [799](#), [806](#)
 - TSC2 softkey, [652](#), [662](#), [799](#), [806](#)
 - TSC3 softkey, [652](#), [662](#), [799](#), [806](#)
 - TSC4 softkey, [652](#), [662](#), [799](#), [806](#)
 - TSC5 softkey, [652](#), [662](#), [799](#), [806](#)
 - TSC6 softkey, [652](#), [662](#), [799](#), [806](#)
 - TSC7, [652](#), [799](#), [806](#)
 - TSC7 softkey, [652](#), [662](#), [799](#), [806](#)
 - TTI field, [1082](#), [1139](#), [1179](#), [1186](#)
 - TTI Frame Clock (RPS9) softkey
 - See* wideband CDMA base band generator subsystem keys and fields
 - Turbo Coding field, [504](#), [551](#)
 - Turbo softkey, [1076](#), [1078](#), [1172](#)
 - Type softkey, [361](#), [369](#)
- U**
- UDI 64 kbps softkey, [1146](#)
- UDI ISDN (25.101) softkey, [1041](#)
- UN3/4 GSM Gaussian softkey
 - See* CDMA ARB subsystem keys
 - See* CDMA2000 ARB subsystem keys
 - See* CDMA2000 BBG subsystem keys and fields
 - See* custom subsystem keys
 - See* DECT subsystem keys
 - See* Dmodulation subsystem keys
 - See* dual ARB subsystem keys
 - See* EDGE subsystem keys
 - See* GPS subsystem keys
 - See* GSM subsystem keys
 - See* NADC subsystem keys
 - See* PDC subsystem keys
 - See* PHS subsystem keys
 - See* TETRA subsystem keys
 - See* wideband CDMA ARB subsystem keys
 - See* wideband CDMA base band generator subsystem keys and fields
- Uncoded softkey, [653](#)
- unit subsystem keys
 - dBm, [170](#)

Index

- dBuV, [170](#)
 - dBuVemf, [170](#)
 - mV, [170](#)
 - mVemf, [170](#)
 - uV, [170](#)
 - uVemf, [170](#)
 - unprotected
 - memory subsystem, [116](#)
 - unspecified RMS, [298](#), [299](#)
 - unspecified RMS noise, [298](#)
 - Up Control 1 softkey, [1017](#)
 - Up Control 2 softkey, [1017](#)
 - Up Custom softkey, [905](#), [940](#), [1017](#)
 - Up Normal softkey, [1017](#)
 - Up TCH All softkey, [905](#), [940](#)
 - Up TCH softkey, [905](#), [940](#)
 - Up VOX softkey, [940](#)
 - Up/Down softkey, [1044](#), [1095](#)
 - Update Display Cycle End Cont softkey, [413](#)
 - Update in Remote Off On softkey, [87](#)
 - Uplink MCS-1 softkey, [648](#), [651](#), [800](#)
 - Uplink MCS-5 softkey, [653](#)
 - Uplink MCS-9 softkey, [653](#)
 - Uplink Timing Advance softkey
 - See* sense subsystem keys
 - uploading files, [116](#)
 - user
 - documentation, [lxxi](#)
 - User File softkey
 - See* CDMA2000 BBG subsystem keys and fields
 - See* custom subsystem keys
 - See* DECT subsystem keys
 - See* EDGE subsystem keys
 - See* GPS subsystem keys
 - See* GSM subsystem keys
 - See* NADC subsystem keys
 - See* PDC subsystem keys
 - See* PHS subsystem keys
 - See* TETRA subsystem keys
 - See* wideband CDMA base band generator
 - subsystem keys and fields
 - user files, HSDPA, [818](#)
 - user files, HSPA, [674](#)
 - User FIR softkey
 - See* CDMA ARB subsystem keys
 - See* CDMA2000 ARB subsystem keys
 - See* CDMA2000 BBG subsystem keys and fields
 - See* custom subsystem keys
 - See* DECT subsystem keys
 - See* Dmodulation subsystem keys
 - See* dual ARB subsystem keys
 - See* EDGE subsystem keys
 - See* GPS subsystem keys
 - See* GSM subsystem keys
 - See* NADC subsystem keys
 - See* PDC subsystem keys
 - See* PHS subsystem keys
 - See* TETRA subsystem keys
 - See* wideband CDMA ARB subsystem keys
 - See* wideband CDMA base band generator
 - subsystem keys and fields
 - User Flatness softkey, [103](#), [124](#)
 - User FSK softkey
 - See* custom subsystem keys
 - See* DECT subsystem keys
 - See* EDGE subsystem keys
 - See* GSM subsystem keys
 - See* NADC subsystem keys
 - See* PDC subsystem keys
 - See* PHS subsystem keys
 - See* TETRA subsystem keys
 - User I/Q softkey
 - See* custom subsystem keys
 - See* DECT subsystem keys
 - See* EDGE subsystem keys
 - See* GSM subsystem keys
 - See* NADC subsystem keys
 - See* PDC subsystem keys
 - See* PHS subsystem keys
 - See* TETRA subsystem keys
 - uV softkey, [170](#)
 - uVemf softkey, [170](#)
 - UW softkey, [962](#), [963](#), [980](#), [981](#)
 - UWCDMA softkey, [104](#)
- ## V
- View Next Error Message softkey, [155](#)

W

- Walsh Code softkey, [252](#), [255](#)
- Walsh field
 - See* CDMA2000 BBG subsystem keys and fields
- waveform
 - sequence, dual ARB, [317](#)
- Waveform Length softkey, [212](#), [238](#)
- waveform license time remaining, [84](#)
- Waveform Licenses softkey, [82](#), [84](#)
- Waveform Runtime Scaling softkey, [316](#), [339](#)
- waveform scaling
 - during playback, [316](#), [339](#)
 - files, [316](#)
- waveform, creating a multitone, [330](#)
- W-CDMA Off On softkey, [383](#), [1186](#)
- WCDMA softkey
 - See* CDMA ARB subsystem keys
 - See* CDMA2000 ARB subsystem keys
 - See* Dmodulation subsystem keys
 - See* dual ARB subsystem keys
 - See* wideband CDMA ARB subsystem keys
- wideband AM, [173](#)
- wideband CDMA ARB subsystem keys
 - 1 DPCH, [352](#), [358](#)
 - 2 Carriers, [353](#)
 - 2.100 MHz, [350](#)
 - 3 Carriers, [353](#)
 - 3 DPCH, [352](#), [358](#)
 - 4 Carriers, [353](#)
 - 40.000 MHz, [348](#), [350](#)
 - APCO 25 C4FM, [346](#)
 - Apply Channel Setup, [361](#), [369](#)
 - ARB Reference Ext Int, [375](#)
 - ARB Sample Clock, [377](#)
 - Bus, [380](#)
 - Channel, [361](#), [369](#)
 - Chip Rate, [346](#)
 - Clear Header, [348](#)
 - Clip |I| To, [344](#), [355](#)
 - Clip |Q| To, [344](#), [356](#)
 - Clip At PRE POST FIR Filter, [344](#)
 - Clip Type |I+jQ| To, [345](#), [356](#)
 - Clipping Type |I+jQ| |I|,|Q|, [345](#), [356](#)
 - Continuous, [377](#)
 - Custom WCDMA State, [368](#)
 - DPCCCH, [368](#)
 - DPCCCH + 1 DPDCH, [368](#)
 - DPCCCH + 2 DPDCH, [368](#)
 - DPCCCH + 3 DPDCH, [368](#)
 - DPCCCH + 4 DPDCH, [368](#)
 - DPCCCH + 5 DPDCH, [368](#)
 - DPCH, [362](#)
 - Equal Energy per Symbol, [366](#)
 - Ext Delay Off On, [381](#)
 - Ext Delay Time, [381](#)
 - Ext Key, [380](#)
 - Ext Polarity Neg Pos, [382](#)
 - Filter Alpha, [347](#)
 - Filter BbT, [347](#)
 - First Spread Code, [361](#), [369](#)
 - Free Run, [379](#)
 - Gain Unit dB Lin Index, [371](#)
 - Gate Active Low High, [379](#)
 - Gated, [377](#)
 - Gaussian, [346](#)
 - I/Q Mapping Norma Invert, [349](#)
 - I/Q Mod Filter Manual Auto, [351](#)
 - I/Q Output Filter Manual Auto, [349](#)
 - Increment Scramble Code, [357](#)
 - Increment Timing Offset, [360](#)
 - IS-2000 SR3 DS, [346](#)
 - IS-95, [346](#)
 - IS-95 Mod, [346](#)
 - IS-95 Mod w/EQ, [346](#)
 - IS-95 w/EQ, [346](#)
 - Left Alternate, [361](#)
 - Link Down Up, [351](#)
 - Marker 1, [372](#), [373](#)
 - Marker 2, [372](#), [373](#)
 - Marker 3, [372](#), [373](#)
 - Marker 4, [372](#), [373](#)
 - Marker Polarity Neg Pos, [375](#)
 - Modulator Atten Manual Auto, [350](#)
 - None, [372](#), [373](#)
 - Nyquist, [346](#)
 - OCNS, [362](#)
 - Optimize ACP ADJ ALT, [351](#), [367](#)
 - Optimize FIR For EVM ACP, [348](#)
 - Patt Trig In 1, [382](#)
 - Patt Trig In 2, [382](#)

Index

- PCCPCH + SCH, [352](#), [358](#)
- PCCPCH + SCH + 1 DPCH, [352](#), [358](#)
- PCCPCH + SCH + 3 DPCH, [352](#), [358](#)
- PICH, [362](#)
- Power, [369](#)
- PPCCPCH, [362](#), [363](#)
- PSCH, [362](#)
- Random, [361](#), [369](#)
- Rectangle, [346](#)
- Reference Freq, [375](#)
- Reset & Run, [379](#)
- Retrigger Mode Off On, [376](#)
- Right Alternate, [361](#)
- Root Nyquist, [346](#)
- Save Setup To Header, [348](#)
- Scale to 0dB, [366](#)
- SCCPCH, [362](#), [363](#)
- Scramble Code, [361](#), [367](#), [369](#)
- Scramble Offset, [361](#), [369](#)
- Second DPDCH I Q, [367](#)
- Single, [377](#)
- SSCH, [362](#)
- Standard, [361](#)
- Store Custom W-CDMA State, [357](#), [360](#)
- Store To File, [369](#)
- Symbol Rate, [361](#), [369](#)
- Test Model 1 w/16 DPCH, [352](#), [358](#)
- Test Model 1 w/32 DPPCH, [352](#), [358](#)
- Test Model 1 w/64 DPCH, [352](#), [358](#)
- Test Model 2, [352](#), [358](#)
- Test Model 3 w/16 DPCH, [352](#), [358](#)
- Test Model 3 w/32 DPCH, [352](#), [358](#)
- Test Model 4, [352](#), [358](#)
- Test Model 5 w/2HSPDSCH, [352](#), [358](#)
- Test Model 5 w/4HSPDSCH, [352](#), [358](#)
- Test Model 5 w/8HSPDSCH, [352](#), [358](#)
- TFCI Field Off On, [361](#), [366](#), [369](#), [371](#)
- Through, [348](#), [350](#)
- Trigger & Run, [379](#)
- Trigger Key, [380](#)
- Type, [361](#), [369](#)
- UN3/4 GSM Gaussian, [346](#)
- User FIR, [346](#)
- WCDMA, [346](#)
- W-CDMA Off On, [383](#)
- wideband CDMA base band generator subsystem
 - keys and fields
 - # of Blocks, [1079](#)
 - 1/2 Conv, [1076](#), [1078](#), [1172](#)
 - 1/3 Conv, [1076](#), [1078](#), [1172](#)
 - 10 msec, [1105](#)
 - 10ms Frame Pulse (DRPS11), [1058](#), [1060](#), [1061](#), [1062](#), [1063](#)
 - 10ms Frame Pulse (RPS6), [1154](#), [1156](#), [1157](#), [1158](#), [1159](#)
 - 12.2 kbps (34.121), [1041](#)
 - 144 kbps (34.121), [1041](#)
 - 20 msec, [1105](#)
 - 2560 msec, [1105](#)
 - 2nd Scr Offset, [1042](#), [1049](#)
 - 3.84MHz chip-clk (DRPS4), [1058](#), [1060](#), [1061](#), [1062](#), [1063](#)
 - 384 kbps (34.121), [1041](#)
 - 40 msec, [1105](#)
 - 64 kbps (34.121), [1041](#)
 - 80 msec, [1105](#)
 - 80ms Frame Pulse (DRPS13), [1058](#), [1060](#), [1061](#), [1062](#), [1063](#)
 - 80ms Frame Pulse (RPS20), [1154](#), [1156](#), [1157](#), [1158](#), [1159](#)
 - A, [1033](#)
 - ACS, [1072](#)
 - Active, [1069](#)
 - Actual BER, [1181](#)
 - Actual BLER, [1175](#), [1182](#)
 - AICH, [1139](#)
 - AICH Trigger Polarity Pos Neg, [1114](#)
 - All Down, [1044](#), [1095](#)
 - All Up, [1044](#), [1095](#)
 - Alt power in, [1152](#)
 - AMR 12.2 kbps, [1041](#), [1146](#)
 - APCO 25 C4FM, [1045](#), [1106](#)
 - Apply Channel Setup, [1029](#), [1084](#)
 - B, [1033](#)
 - Base Delay Tp-a, [1136](#)
 - BBG Chip Clock Ext Int, [1028](#)
 - BBG Data Clock Ext In, [1032](#)
 - BER, [1175](#), [1177](#), [1182](#), [1184](#)
 - Beta, [1088](#), [1098](#)
 - BLER, [1176](#), [1177](#), [1183](#), [1184](#)

- Blk Set Size, 1075
- Blk Size, 1074, 1171, 1179
- Blocking, 1072
- Burst gate in, 1153
- C Power, 1085
- C Power value, 1115
- C/N value, 1029, 1084, 1114
- CFN #0 Frame Pulse (RPS10), 1148
- Chan Code, 1038, 1039, 1048
- Channel Code, 1053, 1089, 1099, 1140, 1141
- Channel Code field, 1052
- Channel State, 1098, 1105
- Channel State Off On, 1032, 1036, 1037, 1039, 1045, 1047, 1050, 1051, 1053, 1055, 1063, 1087, 1117, 1172, 1179, 1180
- ChCode Ctl, 1130
- ChCode Dat, 1130
- Chip Clock (RPS1), 1148, 1154, 1156, 1157, 1158, 1159
- Chip Rate, 1038, 1088
- Comp Mode Start Trigger Polarity Neg Pos, 1169
- Comp Mode Start Trigger Polarity Pos Neg, 1070, 1071
- Comp Mode Stop Trigger Polarity Neg Pos, 1169
- Comp Mode Stop Trigger Polarity Pos Neg, 1071
- Compressed Mode Off On, 1168
- Compressed Mode Start Trigger, 1047, 1070, 1169
- Compressed Mode Stop Trigger, 1071, 1169
- CRC Size, 1077, 1173, 1180
- Ctrl Beta, 1118
- Ctrl Pwr, 1119
- Data, 1100
- Data Beta, 1122
- Data field, 1184
- Data Pwr, 1124
- Data Rate, 1049
- DCH1, 1086
- DCH2, 1086
- DCH3, 1086
- DCH4, 1086
- DCH5, 1086
- DCH6, 1086
- DL Reference 1.1, 1167
- DL Reference 1.2, 1167
- DL Reference 2.1, 1167
- DL Reference 2.2, 1167
- Down/Up, 1044, 1095
- DPCCH, 1086, 1109
- DPCCH Pilot data-clk (DRPS23), 1058, 1060, 1061, 1062, 1063
- DPCCH Power, 1092
- DPCCH Raw Data (RPS4), 1148
- DPCCH Raw Data Clock (RPS5), 1148
- DPCCH TFCI data-clk (DRPS22), 1058, 1060, 1061, 1062, 1063
- DPCCH TPC indicator (DRPS21), 1058, 1060, 1061, 1062, 1063
- DPCH + 1, 1030, 1031
- DPCH + 2, 1030, 1031
- DPCH 10ms Frame-Pulse (DRPS26), 1058, 1060, 1061, 1062, 1063
- DPCH Channel Balance, 1038
- DPCH Compressed Frame Indicator (DRPS32), 1058, 1060, 1061, 1062, 1063
- DPCH data stream (DRPS24), 1058, 1060, 1061, 1062, 1063
- DPCH data-clk (0) (DRPS28), 1058, 1060, 1061, 1062, 1063
- DPCH Gap Indicator (DRPS33), 1058, 1060, 1061, 1062, 1063
- DPCH TimeSlot pulse (DRPS25), 1058, 1060, 1061, 1062, 1063
- DPDCH, 1086
- DPDCH data-clk withDTX (DRPS20), 1058, 1060, 1061, 1062, 1063
- DPDCH data-clk WithOutDTX (DRPS30), 1058, 1060, 1061, 1062, 1063
- DPDCH Power, 1101
- DPDCH Raw Data (RPS2), 1148
- DPDCH Raw Data Clock (RPS3), 1148
- Eb/No, 1115
- Eb/No value (dB), 1085
- Ec/No value, 1030, 1116
- Equal Powers, 1051, 1109
- Error BER, 1181
- Error Bits, 1174
- Error Blocks, 1175
- Ext, 1044
- Ext Clock Rate x1 x2 x4, 1028
- FBI State, 1091

Index

- Filter Alpha, 1046, 1107
- Filter BbT, 1046, 1108
- FIX, 1091
- FIX4, 1040, 1051, 1052, 1053, 1054, 1077, 1078, 1090, 1100, 1118, 1119, 1121, 1123, 1177, 1181
- Flat Noise BW, 1086
- Frame Clock Polarity Neg Pos, 1106
- Frame Struct, 1065
- Frame Sync Trigger Mode Single Cont, 1161
- Gaussian, 1045, 1106
- Higher Layer, 1164
- Infinity, 1068, 1166
- Init Power, 1110
- Init Pwr, 1128, 1143
- Intermod, 1072
- IS-95, 1045, 1106
- IS-95 Mod, 1045, 1106
- IS-95 Mod w/EQ, 1045, 1106
- IS-95 w/EQ, 1106
- Left, 1034
- Link Down Up, 1083
- Max Input, 1072
- Max Power, 1111
- Max Pwr, 1129, 1144
- Message Data Raw Data (RPS11), 1154, 1156, 1157, 1158, 1159
- Message Part, 1127
- Message Pulse (RPS22), 1154, 1156, 1157, 1158, 1159
- Message-Control Raw Data (RPS13), 1156, 1157, 1158, 1159
- Message-Control Raw Data Clock (RPS12), 1154, 1156, 1157, 1158, 1159
- Min Power, 1111
- Msg Ctrl, 1116
- Msg Data, 1116
- Msg Pwr, 1127, 1142
- N Power, 1087, 1117
- NONE, 1172
- None, 1076, 1078, 1177, 1184
- NONE (RPS0), 1148, 1154, 1156, 1157, 1158, 1159
- Normal, 1034
- Num of Blk, 1178, 1185
- Num of Pre, 1128, 1143
- Number of AICH, 1113
- Number of PRACH, 1140, 1142
- Number of PRACH 80ms, 1127
- Number of Preamble, 1143
- Nyquist, 1045, 1106
- Off, 1139
- Omitted, 1068, 1166
- On, 1139
- On/Off, 1050, 1132
- OpenLoop Ant1, 1073
- OpenLoop Ant1 SCH TSTD OFF, 1073
- OpenLoop Ant2, 1073
- OpenLoop Ant2 SCH TSTD OFF, 1073
- Optimize FIR For EVM ACP, 1047, 1108
- Paging Indicator, 1054
- Pattern trigger in 1, 1153
- Pattern trigger in 2, 1154
- PCCPCH, 1030, 1031
- P-CCPCH data (DRPS39), 1058, 1060, 1061, 1062, 1063
- P-CCPCH data-clk (DRPS38), 1058, 1060, 1061, 1062, 1063
- Performance Req, 1072
- Phase Polarity Normal Invert, 1055
- Phase Polarity Normal Inverted, 1083
- PI Bits, 1054
- PICH, 1030, 1031
- PICH 10ms FramePulse (DRPS37), 1058, 1060, 1061, 1062, 1063
- PICH data (DRPS35), 1058, 1060, 1061, 1062, 1063
- PICH data-clk (DRPS34), 1058, 1060, 1061, 1062, 1063
- PICH TimeSlot Pulse (DRPS36), 1058, 1060, 1061, 1062, 1063
- Playback Ratio, 1034
- PN15, 1033, 1039, 1048, 1051, 1053, 1089, 1090, 1093, 1095, 1100, 1118, 1121, 1123
- PN9, 1033, 1039, 1048, 1051, 1053, 1077, 1089, 1090, 1093, 1095, 1100, 1118, 1121, 1123, 1173, 1181
- Power, 1034, 1037, 1040, 1048, 1052, 1055, 1056
- Power Control Signal Polarity Neg Pos, 1113
- Power Hold Off On, 1110

Power Mode Norm TPC, 1113
Pp-m, 1129, 1145
PRACH, 1109
PRACH Mode Single Multi, 1126
PRACH Power Setup Mode Pp-m Total, 1133
PRACH Processing (RPS19), 1154, 1156, 1157, 1158, 1159
PRACH Scrambling Code, 1134
PRACH Trigger, 1138
PRACH Trigger Polarity Neg Pos, 1138
PRACH Trigger Source Immedi Trigger, 1138
Pre Sig, 1130
Preamble, 1116
Preamble power average, 1132
Preamble Pulse (RPS21), 1154, 1156, 1157, 1158, 1159
Preamble Raw Data (RPS15), 1154, 1156, 1157, 1158, 1159
Preamble Raw Data Clock (RPS16), 1154, 1156, 1157, 1158, 1159
PSCH State, 1056
Puncture, 1066, 1178, 1185
PwrOffs, 1065, 1163
RACH TrCH, 1116
Ramp Step, 1129, 1144
Rate Match Attr, 1082, 1178, 1185
Rectangle, 1045, 1106
Ref Data Rate, 1085, 1115
Ref Sensitivity, 1072
Reset to Initial Power, 1112
Right, 1034
RMC 144 kbps (25.141), 1146
RMC 384 kbps (25.141), 1146
RMC 64 kbps (25.141), 1146
RMC122 kbps (25.141), 1146
Root Nyquist, 1045, 1106
Scale to 0dB, 1051, 1109
SCFN, 1070, 1168
SCH slot-pulse (DRPS10), 1058, 1060, 1061, 1062, 1063
Scrambling Code, 1063, 1064, 1160
SF/2, 1164
SF2, 1066
SFN reset-signal (DRPS5), 1058, 1060, 1061, 1062, 1063
SFN RST Polarity, 1160
SFN-CFN Frame Offset, 1109
Signature, 1145
Slot Format, 1035, 1042, 1092, 1103, 1120, 1125
Spurious Response, 1072
SSCH 2nd Scramble Group, 1064
SSCH Power, 1064
SSCH State, 1065
Start Access Slot Position in 80ms Period, 1131
Start Sub-Channel#, 1135
STD, 1089
Step Power, 1112
Sub Channel Timing (RPS17), 1154, 1156, 1157, 1158, 1159
Symbol Rate, 1092, 1101, 1120, 1124
Sync Source SFN FClk ESG, 1161
tDPCH Offset, 1043
TFCI Pat, 1043
TFCI Pattern, 1093, 1121
TFCI State, 1094, 1122
Tfirst, 1036
TGCFN, 1066, 1163
TGD, 1067, 1164
Tgl, 1036
TGL1, 1067, 1165
TGL2, 1067, 1165
TGPL1, 1068, 1165
TGPL2, 1166
TGPRC, 1166
TGPS Inactive Active, 1167
TGSN, 1069, 1167
Timeslot Offset, 1134
Timing Offset, 1135, 1160, 1170
tOCNS Offset, 1050
Total Bits, 1174
Total Blocks, 1176
TotalPwr, 1087, 1117
TPC Pat Steps, 1094
TPC Pat Trig Polarity Neg Pos, 1096
TPC Pattern, 1096
TPC Steps, 1044
TPC UserFile Trig, 1097
Tp-m, 1136
Tp-p, 1137
Transp Chan A, 1039

Index

Transp Chan B, [1039](#)
Transp Position Flexible Fixed, [1081](#)
Transport CH, [1051](#)
TrCH BER, [1102](#)
TrCh BlkSize 168, [1133](#)
TrCh BlkSize 360, [1133](#)
TrCH State Off On, [1083](#), [1186](#)
Trigger Sync Reply (RPS7), [1154](#), [1156](#), [1157](#),
[1158](#), [1159](#)
TTI, [1082](#), [1139](#), [1179](#), [1186](#)
TTI Frame Clock (RPS9), [1148](#)
Turbo, [1076](#), [1078](#), [1172](#)
UDI 64 kbps, [1146](#)
UDI ISDN (25.101), [1041](#)
UN3/4 GSM Gaussian, [1045](#)
Up/Down, [1044](#), [1095](#)
User File, [1039](#), [1044](#), [1051](#), [1053](#), [1077](#), [1089](#),
[1090](#), [1093](#), [1100](#), [1118](#), [1121](#), [1123](#), [1173](#),
[1181](#)
User FIR, [1045](#), [1106](#)
W-CDMA Off On, [1186](#)
Word Alignment softkey, [390](#)
Word Size softkey, [397](#)